

Running Head: INSTRUCTIONAL REMEDIATION OF PHYSICS MISCONCEPTS

IDENTIFICATION OF MISCONCEPTIONS IN PHYSICS AND TESTING OF  
EFFECTIVENESS OF CERTAIN INSTRUCTIONAL PROGRAMMES  
ON REMEDIATION OF THE MISCONCEPTS AMONG  
VIII STANDARD STUDENTS IN KERALA

*Thesis*  
*Submitted for the degree of*  
DOCTOR OF PHILOSOPHY IN EDUCATION

*By*

**AKHILESH P.T.**

*Supervised By*

**Dr. ABDUL GAFOOR K.**  
Associate Professor

**DEPARTMENT OF EDUCATION**  
**UNIVERSITY OF CALICUT**  
2014

# *Certificate*

This is to certify that the thesis entitled “**IDENTIFICATION OF MISCONCEPTIONS IN PHYSICS AND TESTING OF EFFECTIVENESS OF CERTAIN INSTRUCTIONAL PROGRAMMES ON REMEDIATION OF THE MISCONCEPTS AMONG VIII STANDARD STUDENTS IN KERALA**” is an authentic record of research work carried out by **AKHILESH P.T**, for the degree of Doctor of Philosophy in Education, University of Calicut, under my supervision and guidance and that no part thereof has been presented before any other degree, Diploma or Associateship in any other University.

Place: Calicut University  
Date:

Dr. ABDUL GAFOOR, K.  
(Supervising teacher)

## **DECLARATION**

I, **AKHILESH P.T.**, do here by declare that this thesis entitled as “**IDENTIFICATION OF MISCONCEPTIONS IN PHYSICS AND TESTING OF EFFECTIVENESS OF CERTAIN INSTRUCTIONAL PROGRAMMES ON REMEDIATION OF THE MISCONCEPTS AMONG VIII STANDARD STUDENTS IN KERALA**” is a genuine record of the research work done by me under the supervision of **Dr. ABDUL GAFOOR K.** Associate Professor, **Department of Education, University of Calicut**, and that no part of the thesis has been presented earlier for the award of any Degree, Diploma or Associateship in any University.

Place: Calicut University

**AKHILESH P.T.**

Date:

## *Acknowledgement*

I extend my heartfelt gratitude to my teachers. Without their support and encouragement, I could not submit my Ph.D thesis. I express my affectionate feelings towards my parents; they provided all the needful to me in the tenure of my research work. My wife who has always supported me during my research work, she helped to coordinate all the research related works.

My supervising teacher **Dr. K. Abdul Gafoor Sir** provided infinite freedom in the study with constant and well-directed guidance. I remember his support and help right from the beginning of my M.Ed programme. Without his help I will not be able to submit my thesis. I express my whole hearted and sincere gratitude to him for spending his precious time for my study. I extend my sincere gratitude to Mumtaz teacher and children for their support and assistance at their home.

I express my heartfelt gratitude to Dr. Mohammed Shafi, my teacher from Dept. of Chemistry, University of Calicut, who gave me a direction in my study and life.

I also extend my sincere gratitude to the heads of the department of Education during my research work. I express my thankfulness to Dr. C. Naseema, under whom I started my M.Ed thesis work. I started my study in the department under the headship of Dr. Usha teacher, Dr. P.K. Aruna teacher extended her affection whenever I approached her during the span of my study. Dr. Meera teacher gave me support and freedom, I enjoyed the freedom to seek help during her headship for various

programmes. I express my thankfulness toward Dr. Baiju K. Nath from whom I got some sparks in thinking process and I express gratitude towards Dr. T. Vasumathi for the affection she gave me. Extending my token of gratitude to Dr. Muhammedunni Alias Musthafa for his constant encouragement for active involvement in all spheres of life. Also remembering Dr. Hameed sir for his soft approach to students' at any time.

My study got a direction in the early stage by the help of beloved Prof. T.C. Ayyshabi teacher, who gave me valuable suggestions in framing the structure of the study. I express my gratitude to her kind attention towards me. Also remembering Dr. V. Sumangala teacher for cementing the basics of statistics which paved the way for the completion of research work.

I extend my sincere gratitude to Dr. K. Sivaraman Sir, and Dr. Baby Shary and Prof. Kelu Sir for their kind encouragement and constant support.

I extend my sincere gratitude to Prof M.A. Sudheer, Head, Gandhigram Rural University for his valuable suggestions during my PQE viva.

I express my sincere gratitude to non teaching staff for their co-operation during my tenure, especially Mr. Gafoor Librarian of the Department Library science who offered all support from the library and Sajna, Asst. Dept. of Education, who always helped to tackle technical issues with a pleasant attitude.

I extend my heartfelt thanks to Neena K Kottalil, Hashkar, Shareeja Ali , Raghisha, Remia, Elizabeth, Ashraf, Reena Pramod, Abidha Kurukkan and especially to Mini Narayanan for her immense help in proof reading.

I extend my gratitude greetings to All Kerala Research Scholars Association and Students Federation of India by which I got numerous opportunities and help. And also I extend my gratitude towards my friends' Pramod, Reesha, Sajnes, Manikandan, Haridasan, Arshad, Fazil, Jamsheedali, Sharshad, Santhosh Shreevihar, Shibi, Lineesh, Biju Lukose, Rajesh, Dr. Sivadasn, Vinod PA, Sukul and Raviettan on their support and camaraderie

I express my whole hearted thanks to all the heads, teachers, and students of various schools who extended their co-operation during the data collection for my survey and experimentation and especially to Venugopal sir Head master of my school, Bincy teacher, Indhuraj, Azeez sir and Vinodettan who gave me support to collect data from various schools.

I express my sincere gratitude to Rajesh, Baluettan, Raman and Sreejith for their technical support in submitting the thesis.

I express my heartfelt thanks to all those who have helped and supported me for the successful completion of my research work.

**Akhilesh P.T.**

# CONTENTS

LIST OF TABLES

LIST OF FIGURES

LIST OF APPENDICES

<i>Chapter</i>	<i>Title</i>	<i>Page No.</i>
<b>I</b>	<b>INTRODUCTION</b>	<b>1-12</b>
	Need and Significance of the Study	
	Statement of the Problem	
	Definition of Key Terms	
	Objectives of the Study	
	Hypothesis	
	Methodology	
	Scope and Limitations of the Study	
<b>II</b>	<b>REVIEW OF RELATED LITERATURE</b>	<b>13-90</b>
	Concepts, Misconcepts and their Development	
	Conceptual Change	
	Studies on: Misconcepts in Physics	
	Effectiveness of Conceptual Change Strategies	
	Conclusion	
<b>III</b>	<b>METHODOLOGY</b>	<b>91-114</b>
	Phase 1: Survey of Misconceptions in Major Areas of Physics among Standard VIII Students	
	Phase 2: Intervention for Remedying the Misconceptions in Physics	
<b>IV</b>	<b>ANALYSIS</b>	<b>115-176</b>
	Extent of Misconception on Physics among Secondary School Students	
	Concept wise Percentage of Incidence of Misconception in 14 Selected Concepts.	
	Extent of Incidence of Misconception on the Minor Concepts of Physics	
	Comparison of Proportions in Subsamples	
	Effectiveness of Instructional Programmes for Remediation of Misconcepts in Physics	
<b>V</b>	<b>SUMMARY, FINDINGS, AND SUGGESTIONS</b>	<b>177-194</b>
	Objectives of the Study	
	Methodology	
	Major Findings of the Study	
	Conclusion	
	Educational Implications of the Findings	
	<b>BIBLIOGRAPHY</b>	<b>195-216</b>
	<b>APPENDICES</b>	

## LIST OF TABLES

<i>Table No.</i>	<i>Title</i>	<i>Page No.</i>
1.	Item Number which are Representing Minor Concepts Corresponding to the Major Concept Areas in Physics	99
2.	Break Up of Sample Used in Survey Phase	102
3.	School wise Distribution of the Final Sample Used in Survey Phase	103
4.	Concept Areas and Their Weight ages in Abridged Version of Test of Concept Attainment in Physics (Abridged Version) Used in Experimental Phase	107
7.	Outline of Conceptual Change Strategy, Concept Mapping and Participative Approach Applied in Experimental Group	109
8.	Details of strategies used for conceptual change	110
9.	Concept Wise Percentage of Incidence of Misconception on Selected Major Concepts	116
10.	Minor Concepts in the rank order of Percentage of Misconception in the Areas of Matter, Solar System, Density and Pressure	119
11.	Minor Concepts in the order of Percentage of Incidence of Misconception in the Areas of Velocity, Mass, Force, Gravity and Work	121
12.	Minor Concepts in the order of Percentage of Incidence of Misconception in the Areas of Energy, Light, Sound, Magnetism, and Electricity	123
13.	Concept Wise Percentage of Incidence of Misconception in Selected Concepts among Boys	127
14.	Concept Wise Percentage of Incidence of Misconception in Selected Concepts among Girls	128
15.	Comparison of Percentage of Misconceptions on the Major Concepts in Physics among Boys and Girls of Secondary School	129

<b><i>Table No.</i></b>	<b><i>Title</i></b>	<b><i>Page No.</i></b>
16.	Gender Wise Comparison Percentages of Misconception on Minor Concepts in the Area of Matter	131
17.	Gender Wise Comparison Percentages of Misconception on Minor Concepts in the Area of Solar System	131
18.	Gender Wise Comparison Percentages of Misconception on Minor Concepts in the Area of Density	132
19.	Gender Wise Comparison Percentages of Misconception on Minor Concepts in the Area of Pressure	133
20.	Gender Wise Comparison Percentages of Misconception on Minor Concepts in the Area of Velocity	133
21.	Gender Wise Comparison Percentages of Misconception in Minor Concepts in the Area of Mass	134
22.	Gender Wise Comparison Percentages of Misconception on Minor Concepts in the Area of force	135
23.	Gender Wise Comparison Percentages of Misconception on Minor Concepts in the Area of Gravity	135
24.	Gender Wise Comparison Percentages of Misconception in Minor Concepts in the Area of work	136
25.	Gender Wise Comparison Percentages of Misconception in Minor Concepts in the Area of Energy	136
26.	Gender Wise Comparison Percentages of Misconception in Minor Concepts in the Area of Light	137
27.	Gender Wise Comparison Percentages of Misconception in Minor Concepts in the Area of sound	138
28.	Gender Wise Comparison Percentages of Misconception in Minor Concepts in the Area of Magnetism	138
29.	Gender Wise Comparison Percentages of Misconception in Minor Concepts in the Area of Electricity	139
30.	Concept Wise Percentage of Incidence of Misconception on Selected Concepts among Rural Students	143
31.	Concept Wise Percentage of Incidence of Misconception on Selected Concepts among Urban students	144

---

<i><b>Table No.</b></i>	<i><b>Title</b></i>	<i><b>Page No.</b></i>
32.	Comparison of Percentage of Misconception on Major Concepts in Physics among Rural and Urban students of Secondary School	145
33.	Locale Wise Comparison of Percentages of Misconception on Minor Concepts in the Area of Matter	147
34.	Locale Wise Comparison of Percentages of Misconception on Minor Concepts in the Area of Solar System	147
35.	Locale Wise Comparison of Percentages of Misconception on Minor Concepts in the Area of Density	148
36.	Locale Wise Comparison Percentages of Misconception on Minor Concepts in the Area of Pressure	149
37.	Locale Wise Comparison Percentages of Misconception on Minor Concepts in the Area of Velocity	149
38.	Locale Wise Comparison Percentages of Misconception on Minor Concepts in the Area of Mass	150
39.	Locale Wise Comparison Percentages of Misconception on Minor Concepts in the Area of Force	150
40.	Gender Wise Comparison Percentages of Misconception in Minor Concepts in the Area of Gravity	151
41.	Locale Wise Comparison Percentages of Misconception on Minor Concepts in the Area of Work	152
42.	Locale Wise Comparison Percentages of Misconception on Minor Concepts in the Area of Energy	152
43.	Locale Wise Comparison Percentages of Misconception on Minor Concepts in the area of Light	153
44.	Locale Wise Comparison Percentages of Misconception on Minor Concepts in the Area of Sound	154
45.	Gender Wise Comparison Percentages of Misconception on Minor Concepts in the Area of Magnetism	154
46.	Gender Wise Comparison Percentages of Misconception on Minor Concepts in the Area of Electricity	155

---

---

<i>Table No.</i>	<i>Title</i>	<i>Page No.</i>
47.	Test of Significance of Difference between Mean Pretest Scores of Experimental and Control Groups on Concept Attainment in Physics	160
48.	Indices of Pretest Scores of Misconceptions in Select Areas of Physics of Standard Eight Students Prior to Remediation Programmes	162
49.	Comparisons in Concept Attainment in Select Areas of Physics between Experimental and Control Prior to the Application of Remedial Strategies	165
50.	Test of Significance of Difference between Mean Posttest Scores of Experimental and Control Group	166
51.	Indices of Posttest Scores of Misconceptions in Select Areas of Physic of Standard Eight Students after execution of Remediation Programmes	168
52.	Comparison of Concept Attainment between Experimental and Control Groups After the Administration of Instructional Programmes on Remediation of the Misconcepts	171

---

## LIST OF FIGURES

<b>Graph No.</b>	<b>Title</b>	<b>Page No.</b>
1.	Outline of procedure	91
2.	Design: Quasi-Experimental Pretest Posttest	106
3.	Bar diagram of extent of misconception in major concepts in physics among secondary school students	117
4.	Cluster bar diagram of extent of misconception in major concepts in physics among secondary school students by gender	130
5.	Cluster bar diagram of extent of misconception in major concepts in physics among secondary school students by locale	146
6.	Histogram with normal curves best fit on them of pretest scores of concept attainment in physics of experimental and control groups	160
7.	Histograms with normal curve which best fit on them of the distribution of the pretest scores of four areas of standard eight physics on which the effectiveness of remediation of misconception were studied, (showing the match between experimental and control groups on attainment of concepts in these areas prior to intervention)	163
8.	Histogram with normal curves best fit on them of posttest scores of concept attainment in physics of experimental and control groups	168
9.	Histograms with normal curve which best fit on them of the distribution of the posttest scores of four areas of standard eight physics on which the effectiveness of remediation of misconception were studied, (showing difference between experimental and control groups on attainment of concepts in these areas after intervention)	170

## LIST OF APPENDICES

<b>Appendix</b>	<b>Title</b>
I A	Test of Concept Attainment in Physics (TCAP) Longer Version - Malayalam (Draft)
I B	Test of Concept Attainment in Physics (TCAP) Longer Version - English (Draft)
II A	Test of Concept Attainment in Physics (TCAP) Longer Version - Malayalam (Final)
II B	Test of Concept Attainment in Physics (TCAP) Longer Version - English (Final)
III A	Test of Concept Attainment in Physics (TCAP) Abridged Parallel Version (Pre-Test)- Malayalam
III B	Test of Concept Attainment in Physics (TCAP) Abridged Parallel Version (Pre-Test)- English
IV A	Test of Concept Attainment in Physics (TCAP) Abridged Parallel Version (Post-Test)- Malayalam
IV B	Test of Concept Attainment in Physics (TCAP) Abridged Parallel Version (Post-Test)- English
V A	Instructional Programmes for Remediation of Misconcepts- Malayalam
V B	Instructional Programmes for Remediation of Misconcepts- English

# INTRODUCTION

---

- ↪ **NEED AND SIGNIFICANCE OF THE STUDY**
  - ↪ **STATEMENT OF THE PROBLEM**
  - ↪ **DEFINITION OF KEY TERMS**
  - ↪ **OBJECTIVES OF THE STUDY**
  - ↪ **HYPOTHESIS**
  - ↪ **METHODOLOGY**
    - **PHASES OF THE STUDY, VARIABLES, SAMPLE**
    - **MEASURES AND STATISTICAL ANALYSES**
  - ↪ **SCOPE AND LIMITATIONS OF THE STUDY**
-

## **REVIEW OF RELATED LITERATURE**

- 
- ↪ **CONCEPTS, MISCONCEPTS AND THEIR DEVELOPMENT**
    - **TYPES OF CONCEPTS**
    - **MISCONCEPTIONS**
  - ↪ **CONCEPTUAL CHANGE**
  - ↪ **STUDIES ON MISCONCEPTS IN PHYSICS**
  - ↪ **EFFECTIVENESS OF CONCEPTUAL CHANGE STRATEGIES**
  - ↪ **CONCLUSION**
-

## METHODOLOGY

---

↪ **PHASE 1: SURVEY OF MISCONCEPTIONS IN MAJOR AREAS OF PHYSICS AMONG STANDARD VIII STUDENTS**

- VARIABLES IN THE SURVEY PHASE
- DESIGN OF STUDY IN PHASE 1
- TOOLS USED
- SAMPLE FOR THE SURVEY PHASE
- DATA COLLECTION PROCEDURE DURING SURVEY PHASE
- IDENTIFICATION AND EXTENT OF MISCONCEPTIONS IN PHYSICS

↪ **PHASE 2: INTERVENTION FOR REMEDYING THE MISCONCEPTIONS IN PHYSICS**

- VARIABLES IN THE EXPERIMENTAL PHASE
  - EXPERIMENTAL DESIGN
  - TOOLS USED IN THE EXPERIMENTAL PHASE
  - EXPERIMENTAL SAMPLE
  - STATISTICAL TECHNIQUES USED FOR ANALYSIS
-

## ANALYSIS

- 
- ↪ EXTENT OF MISCONCEPTION ON PHYSICS AMONG SECONDARY SCHOOL STUDENTS
  - ↪ PERCENTAGE OF MISCONCEPTION ON THE MAJOR CONCEPTS IN PHYSICS.
  - ↪ PERCENTAGE OF MISCONCEPTION ON THE MINOR CONCEPTS IN PHYSICS
  - ↪ CONCEPT WISE PERCENTAGE OF INCIDENCE OF MISCONCEPTION IN 14 SELECTED CONCEPTS.
  - ↪ EXTENT OF INCIDENCE OF MISCONCEPTION ON THE MINOR CONCEPTS OF PHYSICS
  - ↪ COMPARISON OF PROPORTIONS IN SUBSAMPLES
    - BASED ON GENDER
    - BASED ON LOCALE
  - ↪ EFFECTIVENESS OF INSTRUCTIONAL PROGRAMMES FOR REMEDIATION OF MISCONCEPTS IN PHYSICS
-

## **SUMMARY, FINDINGS, AND SUGGESTIONS**

- 
- ↪ **OBJECTIVES OF THE STUDY**
  - ↪ **METHODOLOGY**
  - ↪ **MAJOR FINDINGS OF THE STUDY**
  - ↪ **CONCLUSION**
  - ↪ **EDUCATIONAL IMPLICATIONS OF THE FINDINGS**
-

## **BIBLIOGRAPHY**

---

## **APPENDICES**

---

# INTRODUCTION

- 
- ↪ **NEED AND SIGNIFICANCE OF THE STUDY**
  - ↪ **STATEMENT OF THE PROBLEM**
  - ↪ **DEFINITION OF KEY TERMS**
  - ↪ **OBJECTIVES OF THE STUDY**
  - ↪ **HYPOTHESIS**
  - ↪ **METHODOLOGY**
    - **PHASES OF THE STUDY, VARIABLES, SAMPLE**
    - **MEASURES AND STATISTICAL ANALYSES**
  - ↪ **SCOPE AND LIMITATIONS OF THE STUDY**
-

Educationists all over the world view education as a very crucial factor in raising the standard of living of common people. It undoubtedly serves as the main agent and component of overall social, economic and political development of a nation. Therefore, every nation wedded to democracy now a day wants to stress on raising the standard of education and streamlining it at all levels. Educational system presently gives much importance to the study of science. The student achievement in science depends a great deal upon the correct formation of concepts. The present system of education is graded to produce citizens who can deal with the words, concepts and scientific symbols that are necessary for success in a technological society. Hence, a widely accepted perspective on the nature of learning is that it is a process of conceptual change (Kyle & Shymansky, 1989; Linder, 1993). Learning is a process in which a student changes conceptions through capturing new ideas and knowledge and replacing the old with the new (Hewson & Hewson, 1991).

Science education aims at increasing common knowledge about science and widening social awareness of scientific findings and issues. Learning science requires learning its language, which often differs from colloquial languages. The language used to communicate science is rife with terms pertaining to concepts, phenomena and processes, which are initially alien to children. Learning science goes beyond scientific facts, principles and theories. One of its aims is to attain conceptual understanding about science.

Children develop ideas about natural phenomena before they are taught science in school. In some instance, these ideas get along with the science that is taught. In many cases, however, there are significant differences between children's notions and school science. Effective science teaching takes account of these ideas and provides activities that enable pupils to make the journey from their current understandings to a more scientific view. Learning of concepts is the main outcome of an educational process.

Students can have misconceptions about scientific facts, models, laws and theories (Brown & Clement, 1987). Misconceptions have a variety of labels in the research literature such as alternative conceptions, alternative frameworks, naïve conceptions, intuitive or spontaneous concepts or alternative interpretations (Linder, 1993; Metere & Tonger, 1989).

Misconceptions are more prone to occur in abstract concepts than in more life related and concrete concepts. Physics is one area in science where students have to learn many concepts that are not tangible. Recent researches in physics education report that students enter physics classes with many preconceived ideas (Brown & Clement, 1987; Marioni, 1989). These preconceptions are often misconceptions in that they do not provide a correct description of the behavior of the physical world, which is consistent with the laws of physics. Whenever these ideas are misconceptions, teachers should try to challenge and discuss them immediately, otherwise students will find it very difficult to model, understand and process the physical world completely.

In a learning process, it is undoubtedly established that students' misconceptions often pose strong barriers to understand physics. Students have many misconceptions related to their own previous experiences or knowledge. The traditional teaching methods often fail to rectify those misconceptions. Arguably, various instructional strategies, instead of traditional lecturing can dispel student misconceptions in physics.

### **Need and Significance of the Study**

The complex and abstract nature of many a concept in science makes them difficult to understand. Nevertheless, complexities are not the only barrier to our understanding science concepts. The subject seems much more difficult due to the presence of numerous misconceptions.

From the developmental view of science education, children do not come to school for the first time at “zero” in science learning. They might have already

reacted to gravity, energy, lightning, thunder, darkness, light, weather and a host of other scientific phenomena. However, many of their experiences could be misconceptions, superstitions and fear. Students bring into school a good attitude for learning and readiness for the development of intelligent and resourceful behavior. Twenty-first century science teaching emphasizes upon the conceptual structure of science in order to enable the pupil to recognize and understand the rapid changes in scientific knowledge. To cope well with the rapidly changing industrial and digital world, pupils must develop and master the essential concepts.

A concept is an abstract idea based on grouping objects or events according to their common properties in order to think and communicate about endless objects, living things and events in the world. A person simplifies them by mentally grouping and organizing based on relationships and features they have in common. The process of constructing rules about how things go together is called concept formation. According to Ausubel (1968) “Concept formation is an act of discovery in which the active role of the learner is emphasized.”

Many of the educationists and psychologists have stressed the importance of concept formation in learning. According to Gagne if the child does not learn concepts and principles that are lower in hierarchy, the learning of those higher in the hierarchy becomes difficult or impossible. Attaining a concept is beneficial to the individual in several ways- in identifying objects around him, in reducing necessity of constant learning and in reducing the complexity of the environment.

The literature study indicated that there exist severe misconceptions among students. For example, students believe that air is not a form of matter, and that heavier objects sink in water irrespective of their densities. Studies in the area of misconceptions show that misconceptions can occur due to various reasons; whatever may be the reason it needs special attention.

Early misconceptions can haunt a student's science learning until the misconception is confronted (Brown & Clement, 1987; Hewson & Hewson, 1983). Students can become confused in physics and mis-learn because of a number of factors. Language usage, everyday experiences, metaphors and textbooks can cause difficulty in students forming acceptable understanding of physics concepts, theories and laws (Brown & Clement, 1987; Ivowi & Oludotun, 1987; Maloney, 1990).

Considering the above given factors, the investigator realized that a study on misconception in physics is as important as a study of concept formation. Misconception may hinder the exact and smooth learning of physics and thereby influence related fields. It makes obstacles in the way of science learning because science is a chain of connected concepts and phenomena. Keeping this in view, the investigator tries to identify major concept areas where misconceptions occur frequently. The investigator also feels that the knowledge of these misconceptions will be useful for science teachers to take up the necessary remedial and compensatory measures for improving the performance in physics.

Studies on misconception can help remove misconceptions by relevant methods and thereby it can contribute to the national development by eradicating superstitions, developing objectivity, open mindedness, critical thinking and by adopting scientific method in solving problems. Therefore, it will be worthwhile to investigate the misconceptions in physics concepts among the secondary schools students in Kerala. Hence, the investigator strongly felt to conduct a study of this kind.

### **Statement of the Problem**

The problem selected for study is stated as "Identification of Misconceptions in Physics and Testing of Effectiveness of Certain Instructional Programmes on Remediation of the Misconcepts among VIII Standard Students in Kerala".

## **Definition of Key Terms**

Definitions of corresponding terms related to the study are given below:

### **Misconceptions in Physics**

Misconceptions in physics as used here means students' non-scientific knowledge about areas such as false concept about scientific terms, definitions and phenomena. Inadequate or lack of acquisition of the most important and indispensable ideas covering important content areas should be mastered at a particular stage in order to get a clear idea of the discipline. Misconceptions are concepts developed in students about scientific processes and beliefs that run counter to the beliefs and theories held by scientists.

### **Certain Instructional Programmes**

Certain instructional programmes stand for the methods other than traditional, which can be used effectively to minimize misconceptions and enhance understanding of important concepts. The proposed strategy is an eclectic one, developed by adopting strategies i.e., strategies of teachers and researchers whose students have relatively less misconceptions of the identified areas of misconceptions. Specifically, this study employed a combination of conceptual change, concept mapping, and participative approaches advocated by previous researchers, which is in tune with present constructivist paradigm being practiced in schools of Kerala.

### **Eighth Standard Students**

Eighth standard students are operationally defined as the students studying in eighth standard of secondary schools affiliated to the Department of General Education, Government of Kerala.

## Objectives of the Study

Present study as indicated in the title is "*Identification of misconceptions in physics and testing of effectiveness of certain instructional programmes on remediation of the misconceptions among VIII standard students in Kerala*".

This involves identifying frequently occurring misconceptions in physics among secondary school students, and verifying the effectiveness of selected instructional strategies in correcting the identified misconceptions among standard VIII students of Kerala. With these broad objectives, the following specific objectives were set for this study.

1. To find out the percentage of error committed in each of the selected concepts in physics viz., (1) Matter, (2) Solar System, (3) Density, (4) Velocity, (5) Mass, (6) Gravity, (7) Work, (8) Energy, (9) Light, (10) Sound, (11) Electricity, (12) Magnetism, (13 ) Pressure and (14) Force by the secondary school students in the total sample.
2. To find out the percentage of error committed in each of the minor concepts involved in selected concepts in physics viz., (1) Matter, (2) Solar System, (3) Density, (4) Velocity, (5) Mass, (6) Gravity, (7) Work, (8) Energy, (9) Light, (10) Sound, (11) Electricity, (12) Magnetism, (13 ) Pressure and (14) Force by the secondary school students.
3. To identify the major concepts in physics and the minor concepts involved with each of them in which there exists significant difference in the percentage of error between boys and girls among VIII standard students of Kerala.
4. To identify the major concepts in physics and the minor concepts involved with each of them in which there exists significant difference in the percentage of error between rural and urban VIII standard students of Kerala.

5. To find out the effectiveness of a range of selected experimental instructional strategies in remediation of the identified misconceptions in physics among VIII standard students of Kerala.

### **Hypotheses of the Study**

1. There will be significant difference in extent of misconception among girls and boys of VIII standard students of Kerala.
2. There will be significant difference in extent of misconception among VIII standard students in rural and urban secondary schools of Kerala.
3. There will be significant decrease in misconceptions after the implementation of selected experimental instructional strategies in remediating the identified misconceptions in physics.
4. The extent of misconception in physics after remedial instruction will be less in the experimental group than in the control group.

### **Methodology**

This study adopts a mixed method approach. The study was completed in two phases, a survey phase leading to an experimental phase.

#### **Variables in the Survey Phase**

Survey phase of the study explored the misconceptions in physics among secondary school students, in the total sample and subsamples based on gender of students and locale of schools.

##### **Attribute variables.**

Survey phase has the following attribute variables, viz.

- 1) Gender
- 2) Locale of schools

**Criterion variables.**

The criterion variables in the survey phase are misconception in physics. This variable is explored in terms of misconceptions in fourteen major conceptual areas of physics viz.,

- i. Matter
- ii. Solar system
- iii. Density
- iv. Pressure
- v. Velocity
- vi. Mass
- vii. Force
- viii. Gravity
- ix. Work
- x. Energy
- xi. Light
- xii. Sound
- xiii. Magnetism
- xiv. Electricity

Misconceptions in each of these fourteen areas are further analyzed in terms of the minor concepts involved in each of the major concepts.

**Variables in the Experimental Phase**

The experimental phase of the study constitutes independent variable and dependent variable. This phase involves testing the effectiveness of select interventions for remedying the misconceptions identified during the survey phase. Hence, this phase has identified independent and dependent variables.

**Independent variable.**

The independent variable of the study is instructional method for remediation of misconception referred to as remedial instruction programme. This variable has two levels, the remedial instruction programme, and a no treatment control. This programme is constituted as an eclectic set of instructional strategies chosen from previous researches, subject to the judgment that such strategies fit to the paradigm of education and infrastructural facilities in schools of Kerala. Specifically, three conceptual change strategies were employed as instructional programmes for remedying misconceptions in physics. They were conceptual change strategy, concept mapping, and participative approach.

Thus, in addition to the effect of total instructional programmes on total concept attainment in physics, the effect of the three strategies individually and in combination on the concept attainment in select areas of physics were studied as follows.

- i. The effect of Conceptual change strategy on Concept attainment in Pressure
- ii. The effect of Concept mapping strategy on Concept attainment in Motion
- iii. The effect of Participative approach on Concept attainment in Sound
- iv. The effect of Conceptual change cum concept mapping strategy on Concept attainment in Force, Density, Magnetism, Light, and Electricity

Hence, the independent variable, remedial instructional programme has four sub-independent variables viz.,

- i. Conceptual change strategy (vs. no treatment control)
- ii. Concept mapping strategy (vs. no treatment control)
- iii. Participative approach (vs. no treatment control)
- iv. Conceptual change cum concept mapping strategy (vs. no treatment control)

**Dependent variable.**

The dependent variable of the study is concept attainment in physics. This variable is quantified as the inverse of misconception in physics. The

concept attainment in physics in total and concept attainment in four broad areas of physics were analyzed for the studying the effectiveness of select set of instructional strategies. The four subset of dependent variables thus studied were:

- i. Concept attainment in Pressure,
- ii. Concept attainment Sound,
- iii. Concept attainment Motion, and
- iv. Concept attainment in Force, Density, Magnetism, Light, and Electricity.

These variables, as mentioned earlier, were quantified as inverse of misconception in these areas.

### **Sample Used for the Study**

There were two sets of samples used in this study. One sample was used in survey phase and the other in the experimental phase.

#### **Survey sample.**

The present study was conducted on a representative sample of 476 secondary school students from eight schools of Kozhikode, Malappuram and Kasaragod revenue districts. Stratified random sampling techniques was used, giving due representation to factors including gender of the pupils and locality of the schools.

#### **Sample for experimental phase.**

A sample of 104 standard eight students from a secondary school randomly selected from the eight schools used in survey phase constitute the sample in the experimental phase. Forty-seven students each in experimental and control groups constitute these 104 students. An intact classroom to which an experimental conceptual change programme was imparted is the experimental group. Forty-seven students, formed by individual-to-individual matching with the experimental group on the pretest scores of conceptual attainment in physics and gender is the control group.

### **Tools Used in the Study**

For the present study the following tools are employed.

- 1) Test of Concept Attainment in Physics - Longer Version (TCAP) (Gafoor and Akhilesh,2010)
- 2) Instructional Programmes on Remediation of the Misconcepts (Gafoor and Akhilesh, 2012)
- 3) Test of concept attainment in physics–Abridged Parallel Versions (TCAP) (Gafoor and Akhilesh, 2012)

Test of concept attainment in physics - Longer Version was employed in survey phase of the study, which was constructed by the investigator with the guidance of the supervising teacher. The objective of the study is to identify the extent of misconception regarding the major areas in physics among secondary school students. The Test of Concept Attainment in Physics composed of 98 items. After tryout, the items were reduced to 80 in number that come under 14 major concepts in physics.

The experimental phase was conducted with the administration of test of concept attainment in physics-abridged version, which included 40 test items covering seven major concepts in physics of which the secondary school pupils of eighth standard are familiar.

In addition to the measuring tools mentioned above, this study employed lessons based on conceptual change strategies viz., conceptual change, concept mapping, and participative approach to remediate the misconceptions among students in the experimental phase.

### **Scope and Limitations of the Study**

The aim of the present study was to find out the extent of misconception in the selected concepts in physics in relation to gender and locality, and to verify the effectiveness of selected instructional strategies in correcting the identified misconceptions among standard VIII students of Kerala. The concepts are

selected based on a thorough analysis of physics concepts present in the Basic science being taught up to standard VIII in schools of Kerala. The concept areas selected to find out the extent of misconception in physics were chosen from interviews with teachers, literature review, and discussion with students. Tests of Concept attainment in physics was constructed, one for survey phase and two parallel versions for experimental phase.

The study was conducted on a sample of 476 pupils of VIII standard of secondary Schools of Kozhikode, Malapuram and Kasaragod districts, drawn by stratified random sampling technique.

The present study tries to test whether there is any difference in the concept attainment in physics and there by tackle misconceptions persistent in Physics between boys and girls, urban and rural pupils. It also finds out the major concept areas where misconceptions occur frequently in minor concepts.

Three strategies for conceptual change viz., conceptual change, concept mapping, and participative approach were chosen based on the topics to be taught in schools and the curricular paradigm being followed in schools, plus, facilities in the school where the experimental sample was situated.

The effects of these strategies on remediation of the identified misconcepts were studied using a quasi-experimental design. Effects of individual strategies on the specific conceptual areas of physics were also explored.

The following are the limitations of the study

1. The study has been restricted to standard VIII which is taken as representatives of secondary school students.
2. Due to practical difficulty, the sample was restricted to only Kozhikode, Malappuram and Kasaragod districts of Kerala.
3. Due to the practical difficulties in time of test administration, some of the areas being taught at school level are avoided and restricted to 14 major concept areas of physics in secondary only.

## **REVIEW OF RELATED LITERATURE**

- 
- ↪ **CONCEPTS, MISCONCEPTS AND THEIR DEVELOPMENT**
    - **TYPES OF CONCEPTS**
    - **MISCONCEPTIONS**
  - ↪ **CONCEPTUAL CHANGE**
  - ↪ **STUDIES ON MISCONCEPTS IN PHYSICS**
  - ↪ **EFFECTIVENESS OF CONCEPTUAL CHANGE STRATEGIES**
  - ↪ **CONCLUSION**
-

The way students make sense of the world and their knowledge is an important issue for improving science education. Consequently, research involving students understanding of scientific concepts has been more prevalent with in educational communities. Students non-scientific performance in specific subject matter domains has been described by many terms, including misconceptions (Eaton & Smith 1983), preconceptions (Clement, 1982), Alternative Conceptions (Gilbert & Swift, 1985) and alternative frame works (Driver and Easley, 1978).

While student misunderstandings across the curriculum is a very popular topic in the staff rooms as well as in more academic settings, science teachers especially have many un answered questions about misconceptions. What is a misconception? Is it merely a misunderstanding? Is a misconception different from a preconception? How does a student develop misconceptions and how can teachers help students overcome their misconceptions? Are there teacher needs to know all these answers to be an effective teacher. This literature survey will answer many of the questions listed above with examples from student misconceptions literature.

## **Concepts, Misconcepts and their Development**

### **Nature of Concepts**

A concept is the basic unit of all types of learning. Human beings from the infancy to old age, learn new concepts and age-old concepts in new situation of their daily life (Lawson & Renner, 1975). Concept is assumed to be as set of specific objects, symbols or events which share common characteristics (critical attributes) and can be defined by a particular name or symbol. Concept learning thus is regarded as the identification of the concept attributes, which can be generalized to newly encountered examples and to discriminate examples from

non example. Concepts can be thought as information about objects, events and process that allow us to-

1. Differentiate various things or classes.
2. To know relationship between objects.
3. Generalize about events, things and processes.

Which are common to a large number of objects and associate these with a symbol, thereafter may be applied to other similar objects.

The word concept is used to designate both mental constructs of individual as well as identifiable public entities that comprise part of the substance of the various disciplines.

### **Definition of Concepts**

In simple term, we may define that concept is an idea or understanding of what a thing is. Logically, a concept refers to phenomenon in a given field that is grouped together because of their common characteristics. There are various definitions for concepts some of them are given below according to their relevance in this context.

Flavell (1970) has indicated that a formal definition of concept in terms of its defining attributes is useful in specifying what concepts are and not, and in understanding the great variability among concepts of a variety of objects.

Kagan (1966) emphasizing the importance of concepts in life says, "Concepts are fundamental agents to intellectual work." The theoretical significance of cognitive concepts in psychological theory parallels the seminal role of valence in chemistry, gene in biology or energy in physics.

According to Pella (1966), a concept may be viewed as 'a summary of essential characteristics of a group of ideas and/or facts that epitomize important common features or factors from a large number of ideas'. This definition

includes the concepts which have entities as well as those learned as principles. (Examples of physics concepts are mass, weight, force, velocity, acceleration, addition of vectors, subtraction of vectors).

### **Development of the Concept**

Concept formation is the process of classifying information into meaningful categories. At its most basic, concept formation is based on experience with positive and negative instances (examples that belong, or do not belong to the concept class).

Bruner makes a difference between concept formation and concept attainment. The process of primitive categorization of objects is called concept formation, in the concept attainment the number of dimensions or specific attribute value are known to the subject before hand and hence he is properly set to find out the definite attributes of a concept.

According to Piaget's theory, scientific knowledge, concepts and conceptual systems are generated through the use of various reasoning strategies which develop continuously through a process of assimilation and accommodation (Inhelder & Piagets, 1958). Much of the conceptual change literature is built up on the Piagetian concepts of assimilation, accommodation, and a lesser degree cognitive disequilibrium. Assimilation is commonly used as the process where by the learner is able to gain new knowledge by fitting new information into existing knowledge structure schema (Tao & Gunstone, 1999). Accommodation however requires changes in structure before the new information can become part of the learner's knowledge or in other words a change in conception (Dykstra, Boyle & Monarch, 1992; Posner, Strike, Hewson & Gertog, 1982). For accommodation to occur usually the learner enters a state of cognitive dis-equilibrium where the learner encounters information or an event that does not fit with existing beliefs (Dykstra, Boyle & Monarch,1992; Posner, Strike, Hewson & Gertog,1982).

The necessary conditions for conceptual change are disequilibrium, assimilation and accommodation, terms introduced by Piaget (1950). Assimilation refers to the recognition of a physical or mental event that fits an existing conception. When an event could not be assimilated under already held conceptions, then accommodation occurs. It is a change in a conception. For accommodation to occur, a student must enter a state of cognitive disequilibrium. If the result of an event does not fit the student's existing conceptions, this situation disequilibrates the student with respect to his current concept. If students can assimilate the concepts presented, then there is no disequilibrium and no conceptual change. Conceptual change can be achieved by disequilibrium, which is the result of an unexpected event. Therefore, instruction should aim to disequilibrate students for conceptual change (Dykstra, 1992).

It has been shown that the concepts involving second degree relationships require formal reasoning strategies. Concrete thinkers can have an intuitive understanding of such concepts, but do not (yet) have the intellectual skills needed to grasp their formal nature. It has also been found that a student can use his formal operational abilities to solve one problem, but cannot solve a different one. The format of the problem and the student's familiarity with the content must also be taken into account (Lovell 1978, Linn and Levine 1978). This familiarity aspect can indeed play an important role in the unfolding of the strategies of formal operation thought, but it can also have a negative effect if preconceptions or misconceptions are present. It must also be recognized that concepts learning can happen at different depths. A student can show abilities which require only his understanding (comprehension) of a concept or he can become also successful in transferring (applying) his knowledge to different contexts (Bloom 1956).

Science teaching should have a conceptual framework which promotes conceptual change. Different researchers used different terms for conceptual change such as weak and strong restructuring (Carey, 1985), branch jumping and

tree switching (Thagard, 1991), conceptual capture and conceptual exchange (Hewson & Hewson, 1992), differentiation and reconceptualization (Dykstra, 1992) and enrichment and revision (Vosniadou, 1994). Each of the theoreticians has developed their own terminology, but there is common ground between the various perspectives of conceptual change. Conceptual change involves changes in students' assumptions about the world and knowing.

One of the most accepted conceptual change theory is posed by Posner *et al.* (1982). In order for conceptual change to take place, Posner *et al.* (1982) suggested four conditions: (1) students must become dissatisfied with their existing conceptions (dissatisfaction); (2) the new concept must be clear and understandable for students (intelligibility); (3) the current problem should be solved by using the new concept (plausibility); (4) similar future problems can be solved by using the new concept (fruitfulness). Therefore, teachers should develop strategies to create cognitive conflict in students, organize instruction to diagnose errors in students' thinking, and help students translate from one mode of representation to another. Conceptual change is not static but is a dynamic process that occurs over a period of time (Chi, 1992). These conditions can be referred to as conceptual change conditions.

### **Types of Concepts**

According to Posner *et al.*, 1982 there are mainly three types of concepts which are described as follows:

#### **Conjunctive concepts.**

Conjunctive concepts are defined by the presence of two or more features. In other words, an item must have “this features and this feature and this feature” for example, a motorcycle must have two wheels and an engine and handle bar.

#### **Disjunctive concepts.**

Disjunctive concepts must have at least one of several possible features. These are either for “concept “.to belongs to the category, an item must have

“this features or that feature or another feature”. For example In base ball, a strike is either a swing and a miss or a pitch over the plate or a foul ball. The either/or equality of disjunctive concepts makes them hard to learn.

### **Relational concepts.**

Relational concepts are based on how an object relates to something else or how its features relate to another. All of the following are relational concepts: Larger, above, north, and upside down.

### **Nature of Concept in Science**

Several authors (Lawson and Renner 1975; Lawson and Nordland 1977; Karplus 1977; Lovell 1978) have already pointed out the strong correlation between students' formal reasoning abilities and their understanding of concepts at different levels of abstraction. The distinction used by Lovell is between physics concepts which relate to concrete references of 'first hand' reality, and those which involve functional relationships, relations between relations and reference models. The former depend on 'first degree relationships', whilst the latter depend on 'second degree relationships' (at the second or third level of abstraction). Likewise, Karplus distinguishes between concrete and formal concepts.

In science context there are mainly two types of concepts Herron (1977) and they are listed below.

### **Concrete concepts.**

According to Herron *et. al.* (1977), concrete concepts' are those concepts which name classes of entities for which there are numerous perceptible instances defining attributes which are easily perceived'. Examples of concrete concepts are: table, chair, thermal degree on the thermometer, force when perceived as a pull by a string.

### **Formal concepts.**

According to Herron, Cantu, Ward and Srinvisan (1977), formal concepts 'are those concepts that do not have perceptible instances, or have defining attributes which are not perceptible', formal concepts are: acceleration, element, density, temperature when defined as the mean kinetic energy of the molecules.

The results of this review show that the comprehension of concrete concepts is significantly dependant on students' cognitive level. Regardless of sex, the higher the cognitive level the better the comprehension of concrete concepts. This finding, although it supports the results of Cantu and Herron (1977), is interesting in that it might have been assumed that once a person had reached the highest level in concrete thought, the acquisition of skills at a higher cognitive level would not make any contribution to the understanding of concrete concepts. This is evidently not a justified assumption. Two explanations may be offered for this:

(1) Formal operations may help in the understanding of concrete concepts by enabling the student to use an expanded frame of reference that helps in accounting for both concrete and formal concepts. This expanded frame of reference may allow the learner to see relationships involving concrete objects, situations, or events previously unrecognized, and consequently, it may bring deeper meaning to concrete as well as formal concepts.

(2) The teaching procedures used in the classrooms are largely expository; consequently, students seldom are confronted with first-hand concrete experiences with any aspect of the discipline. This procedure hinders the student from comprehending concrete concepts until he enters the formal stage.

### **Misconceptions**

Student's non scientific knowledge about subject areas in physics such as false concept about scientific terms, definitions, and phenomena's have been described by many terms including misconceptions (Eatan & Smith; 1983),

Preconception (Clement, 1982), Alternative conceptions (Gilbert & Smith, 1985) and Alternative frame works (Driver & Easley, 1978).

There are several definitions given by many researchers. Some of the valid definitions in this context are given below.

Fisher (1983) defined misconceptions in science as ideas that are at a variance with accepted views.

Odom & Barrow (1995) use the term misconception to refer to students' ideas that are different from the ones generally accepted by scientists.

According to Black & Lucas (1993) people develop ideas about a variety of science topics before they confront the exact theories and concepts about those topics. These ideas tend to remain persistent despite efforts to teach scientifically accepted theories and concepts.

The topic misconceptions are at the heart of the learning and learning process, students need to understand the science content as best, they can in order to make sense of their natural world. Helping students overcome any misconceptions they may be able to only expedite this process.

Students can have misconceptions about scientific facts and Theories (Brows and Clement, 1987). Such misconceptions are an important part of children's culture and significant component of children's science (Renner & Mark 1990). Terry Jones and Herford (1985) found that misconceptions could occur in a students understanding of the scientific method or in the manner in which scientific knowledge is organized (Committee on undergraduate Education 1996, Hammer 1989). Considering the following; if a students learning of a particular concept is dependent upon a lab exercise based on expertise prior to that students mastery of the scientific process or method Their obviously the learning process can be seriously hindered Linder (1993). Gordon (1996) reminds us that if the structure of the knowledge to be learned cannot be aligned to the existing structures within the learner's knowledge there cannot assimilate the new knowledge.

### **Common types of misconceptions.**

There are several types of misconceptions in the learning of science (Tobias, 1987). Distinguishing between types of misconceptions will help the science teacher in identifying their students' difficulties (Eclestein & Shemesh, 1993).

Preconceived notions or preconceptions of the natural world are popular conceptions rooted in every day experience. For example, people observing moving objects slowing (decelerating) mistakenly believe that the force responsible for the motion is getting "used up" (Marioni, 1989). Such misconceptions are very common because they are rooted in the most common activity of young children's, unstructured play. When children are exploring their surroundings, they will naturally attempt to explain some of the phenomena they encounter in their own terms and share their explanations (Terry & Hurford, 1985; Kyle & Shymansky, 1989). When children have an incorrect assumption these preconceptions are also misconceptions.

Factual misconceptions are falsities often learned at an early age and retained unchallenged into adulthood. For example, the idea that "lightning never strikes twice in the same place" is clearly false, but that notion is commonly buried within the teachers and students belief systems (Committee on undergraduate Science Education, 1996, Dysktra & Monarch, 1992).

Vernacular misconceptions arrive from the use of words that mean one thing in everyday life and another in a scientific context. For example, the term "work" in the physics classroom refers to the result of multiplying a force measured in Newton's by the straight line distance moved in meters. The introduction of the definition of work in a physics class can present many challenges to the teacher (Clement 1989). The power (change in energy per unit time) concept is a similar example (committee on undergraduate Education, 1996).

Conceptual misunderstandings are when students are taught scientific information in a manner that does not encourage them to settle any cognitive disequilibrium (Dykstra & Monarch, 1992). In order to deal with their confusion, students construct weak understandings and consequently are very insecure about these constructed concepts. An example of this is very common “force as a property of an object misconception (Brown, 1989). Forces are dependent upon and related to objects but are not properties of them, yet students continually perceive forces are intrinsic to the object (Maloney, 1990; Marioni, 1989).

### **Some sources of misconceptions.**

There are numerous ways that misconceptions can occur. Scientific data are constantly changing. No one person can stay current on all of the new research findings. As a teacher, we are supposed to be teaching the newest and best of scientific information, but by time text books are written and published, much of the information is old. This inability to stay on top of constant change causes misinformation. We also deal with conflicting information into a completely new concept. Parents and teachers relay their misconceptions to the children they teach with little challenge of ideas. Often adults have no idea that they “know” is actually a misconception.

Another way of misconception occurs is by over-simplification of scientific information, either by the media or parents. Trained in science or by teachers and parents in trying to make scientific material understandable, many times the information’s are overly simplified, causing an inaccurate view. The media also tend to have an agenda that slants scientific information to their point of view. One of the worst causes of misconception is cognitive over load. This occur when too much information is presented at one time causing people to shut down all processing because they are over-whelmed with information (University of Massachusetts, 2000). This is detrimental because it can cause children to lose interest in science as a result of the “fear of failure “or “fear of peer group ridicule”. The loss of interest in science during school years can also

eliminate the possibility of pursuing a science related career because of the way it is taught (McLomas, 1996).

Misconceptions can result from deficiencies of curricula and methodologies that do not provide the students with suitable experiences to assimilate the new concept (Ivowi & Oludotun, 1987). It is rarely that misconceptions result from the lack of reasoning abilities that are necessary to assimilate the new concept (Renner & Marek, 1990). Although vernacular and factual misconceptions can often be easily corrected, even by the students themselves, it is not effective for a teacher simply to insist that the learner dismiss preconceived notions and ingrained nonscientific beliefs (Hammer, 1989). Recent research on student's conceptual misunderstandings of natural phenomena indicates that new concepts cannot be learned if alternative models that explain a phenomenon already exist in the learners mind (Tao & Gunstone, 1999).

Early misconceptions can stunt a student's science learning until the misconceptions is confronted and overcome (Brown & Clement 1987; Hewson & Hewson, 1983). Students can become confused in physics and mislearn because of many number of factors, Language usage, everyday experience, analogies, metaphors, examination papers and textbooks (Ivow & Oludotun, 1987) can cause students difficulty in forming acceptable understanding of physics concepts, Theories and laws (Brown and Clement1987) Somewhat surprisingly textbooks have been found to be the most significant source of misconceptions in physics classroom. This is unfortunate as an American study shows a huge dependence on the textbook by high school science teachers (Renner & Marek, 1990). Textbook can mislead students because of poor writing and/ or poor editing.

Often misconceptions are incredibly durable. Many studies have shown students to hold beliefs in contradiction of those used to correctly solve problems (Hammer 1989; Clement and Brown 1987). The tenaciousness of such

misconceptions is not due to the difficulty in acquiring a new concept, but rather the learner's reluctance to relinquish the old familiar misconceptions (Terry & Hurford, 1985). These old concepts are so near and dear to the learner as they developed over time through personal observations of the learner's environment and have grown from firm intuitive beliefs (Kyle & Shymaysky, 1989). These intuitions may be not even be consciously held but still exert a great influence on the learner (Shultz & Murrey, 1987). Confidence in the misconceptions increases over time and becomes more entrenched despite instruction to the contrary. Unfortunately traditional instruction has little impact on removing deeply rooted misconceptions (Brown & Clement, 1987).

Misconceptions often reflect a basic lack of understanding. Hidden beneath the ability to use equations to solve problems (Sandanand & Kess, 1990) many students get through traditional assessments of scientific understandings by merely correctly identifying the known and unknown variables from the problem and then plugging them into the correct formula, which generated the correct answer.

Newtons third law is often misconceived by students in high school and beyond (Brown 1989). This is partially due to the textbook design, as opposed to misconceptions being included in the text or images of the books (Maloney, 1990; Roach, 1992). Traditionally textbooks skim over the third law in terms of examples and resources when compared to the pages allotted to the first two laws. Some texts even confuse the third law with momentum (Roach, 1992). The third law needs to be treated in greater detail as it is key to understanding the qualitative aspects of force with Newtonian mechanics.

The persistence of misconception gives us clues to counter them. Teachers and parents often are not aware of children's incorrect scientific ideas. As a result, adults are unable to challenge students thinking. Misconceptions also persist in children because they are not taught critical thinking skills in school.

Instead, children are taught to memorize facts and to take multiple-choice tests. As a result, when presented with incomplete information, many students do not ask questions otherwise challenge the new information, causing misconceptions to take root and flourish (Podoner, 2000).

Once we know where the students stand, student thinking can be challenged by structuring experience and the learning environment so that there are opportunities for students to “test out” their ideas and prove the correct concepts to themselves (Simanek) while students are testing their ideas, they also need to resolve any conflicts between them during the testing (Podolner, 2000). When finished with activity the teacher must debrief the class, checking for student questions and understanding of the new concepts learned (Podolner, 2000).

### **Children’s Science**

Research studies have shown that children have beliefs about how things happen and expectations that enable them to predict future events (Clement 1977; Nussbaum & Novak 2006; Driver & Easley, 1978). Based on their everyday experiences of the world, they hold these beliefs and expectations very strongly. Moreover, children have clear meanings for words that are used both in everyday language and in formal science (Gilbert, Watts & Osborne, 1980). Such views of the word and meanings for words, held by children are not simply isolated ideas (Champagne, Klopfer & Anderson, 1979) but rather they are part of conceptual structures that provide sensible and coherent understanding of the world from the child’s point of view. These structures may be termed children’s science. Ideas of children’s science may become stepping-stones as well as barriers in the physics learning process. So children’s science concepts must be addressed with due consideration while planning teaching strategies for physics class room learning.

### **Role of Pre-conceptions and Misconceptions in learning process.**

Even young students have well developed ideas of how the world works. These pre-conceptions can hinder their learning in science. Five decades ago, Ausubel (1968) pointed out that these preconceptions are amazingly tenacious and resilient to extinction. Later on, it was found that student preconceptions are so strong that, in some cases they are preserved in the face of obvious and contradictory evidence (Osborne & Freyberg, 1985). Some students accept the teachers' science for the duration of the topic being studied and revert to their intuitive ideas following instruction. In other instances students construct separate schema to accommodate the lesson content without altering their preconceived views. Both preconceptions and learned misconceptions resist conceptual change (Nussbaum & Novick, 1982). Some teachers find this as worrying. However, the strength of student conceptions means that acceptable conceptions, once learned, are robust and lasting. As learned misconceptions and preconceptions may arise as barriers in learning, replacing them with scientific ones is possible only through conceptual change. Franco *et. al* (2011) investigated the role of epistemic beliefs and knowledge representations in cognitive and metacognitive processing when learning about physics concepts through text, they manipulated the representation of physics concepts in texts about Newtonian mechanics and explored how these texts interacted with individuals' epistemic beliefs to facilitate or constrain learning. Results revealed that when individuals' epistemic beliefs were consistent with the knowledge representations in their assigned texts, they performed better on various measures of learning (use of processing strategies, text recall, and changes in misconceptions) than when their epistemic beliefs were inconsistent with the knowledge representations.

Martin-blas (2010) studied to detect systematic errors about the concept of force among freshmen students. The researchers analysed the results of the

Force Concept Inventory test, which was administered to two different groups of students. The results show that, although there were significant performance variations between the two groups, they, nonetheless, shared common incorrect answers that were consistently triggered by the same misconceptions.

### **Conceptual Change**

The root of conceptual change approach to learning can be found in Thomas Kuhn's works on 'Theory change in the philosophy and history of science' (1962). Kuhn proposed that normal science operates within set of shared beliefs, assumptions, commitments and practices that constitute paradigms. Over time, discoveries emerge that cannot be accommodated within the existing paradigms. When those anomalies accumulate, science enters a period of crisis that is eventually resolved by revolutionary change in paradigms, a paradigm shift happens. According to Kuhn, different paradigms are incommensurable; scientific knowledge grows as we move from one to another paradigm, but it is no longer possible to imagine the results of scientific revolutions as a cumulative linear progression. Kuhn claimed that concepts are embedded in theoretical frame works i.e., paradigms- from which they obtain their meaning. When there is a paradigm shift, there is conceptual change. That is, the meanings of concepts in the new paradigm, even when they keep the name they had in the old paradigm are markedly different from the old ones. Such conceptual changes are part of evolution and development of science as a whole. Adopting an evolutionary and genetic epistemological stance, such paradigmatic shifts are part of development of concepts in individual learners as well.

### **Conceptual Change in the Science Classrooms**

Learning in science classrooms can occur under at least three different conditions of prior knowledge. In first condition, a student may have no prior knowledge or information about the 'to be learned concepts', although they may have some related knowledge. In this case, prior knowledge is missing, and learning consists of adding new knowledge. In second condition, a student may

have some correct prior knowledge about to be learned concepts, but that knowledge is incomplete. In this case, learning can be conceived of as gap filling. In both missing and incomplete knowledge conditions, knowledge acquisition is of the enriching kind (Carey, 1991). In a third condition, a student may have acquired ideas, either in school or from everyday experience that are in conflict with to be learned concepts (Vosniadou, 2004). Knowledge acquisition in this third case is of conceptual change kind. It is assumed that the prior knowledge is incorrect or misconceived and to be learned information is correct. Thus, learning in this third condition is not adding new knowledge or gap filling incomplete knowledge. Rather, learning is changing prior misconceived knowledge to correct knowledge. This is termed as conceptual change or process of conceptual change.

### **Classical Approach of Conceptual Change.**

According to White and Gunstone in the 1970's researchers started paying greater attention to student's ideas and explanation of physical phenomena. They started to realize that students held various pre conceptions, misconceptions or alternative beliefs, some of which proved to be very persistent and robust (Viennot, 1979; Driver & Easley, 1978; McCloskey, 1983). In some cases, these misconceptions appeared be very similar to earlier theories in the history of science.

Based on the above, Posner et.al (1982) formed an analogy between the kinds of changes needed to be made by students learning in science and Kuhn's explanations of theory change in science. They claimed that students need to undergo radical conceptual change when it comes to understanding scientific concepts like force or heat energy. They need to replace their preconceptions or misconceptions with the new scientific concepts through instruction. Combining Kuhn's ideas with Piaget's, Posner et.al (1982) derived an instructional theory according to which there are four fundamental conditions that need to be fulfilled before conceptual change happen in science,

- There must be dissatisfaction with existing conceptions.
- There must be a new conception that is intelligible.
- The new conception must appear to be plausible.
- The new concept should suggest the possibility of a fruitful program.

This theoretical structure known as the classical approach to conceptual change became the leading paradigm that guides research and instructional practice in science education for many years. According to the classical conceptual change approach, the student is like a scientist, the process of (science) learning is a rational process of theory of replacement. Conceptual change is like a gestalt shift that happens over a short period. Accordingly, cognitive conflict is the major instructional strategy for promoting conceptual change.

One of the most controversial claims in Kuhn's (1962) original explanation of theory change in science, which was adopted by the classical approach, is that the change from one theoretical framework to the other is an abrupt and sudden change that takes place in a short period. It appears that Gestalt psychology influenced Kuhn and this shift in terms of the gestalt ideas of re-structuring is produced by insight. Although it is possible that such abrupt re-structuring may happen in individual cases during the learning process, this does not appear to be the usual road to conceptual change.

The empirical evidence so far has shown that the course of conceptual change is conservative and slow process. Even when researchers claim that radical conceptual changes are happening in the long run; these are usually the end-state of a slow and gradual process and not of a sudden and radical gestalt type of shift (Caravita & Hullden, 1994). Hence, teaching-learning processes have to be devised to facilitate conceptual changes in science.

### **Important Teaching Strategies Based on Conceptual Change Process**

Research findings in conceptual change have started to use in instructional practice but there is a vast gap between our theoretical and empirical knowledge and classroom practices. Teachers are not well informed about conceptual issues and do not use the recommended instructional strategies for promoting conceptual change in the classroom (Duit, *et.al*, 2008). Hewson and Hewson (1982) commented on traditional instruction as simply introducing new information without paying attention to students existing ways of making sense of ideas related to the concepts.

According to Scott *et.al* (1992), pedagogical decisions should be made at three levels while planning for conceptual change teaching. Firstly, teacher needs to foster a learning environment that will support conceptual change learning. This can be via providing opportunities for discussion and consideration of alternative viewpoints and arguments. A second level of decision-making involves the selection of teaching strategies. Lastly, consideration must be given to the choice of specific learning tasks. The learning task must address the demand of the particular science domain under consideration.

While selecting specific teaching strategies, four factors may need to be taken into consideration:

1. Students' prior conceptions and attitudes
2. The nature of intended learning outcomes
3. Cognitive level or intellectual demand of the learner
4. Possible teaching strategies

Two distinct groups of strategies promote conceptual change. The first group is based on cognitive conflict and resolution of conflicting perspectives. The second set of strategies bases on learners existing ideas.

## **Strategies Based on Cognitive Conflict**

Cognitive conflict has been used as the base of developing a number of teaching strategies. Such strategies involve promoting situations where the students' existing ideas about some phenomenon are made explicit and are then challenged to create cognitive conflict.

### **Strategy based on Piaget's theory of concept learning.**

Nussbaum and Novick (1982) suggest a teaching sequence that draws upon the Piagetian notion of accommodation. It includes four main elements.

- a. *Initial exposure of student preconceptions* through their responses to an exposing event
- b. *Sharpening student awareness* of own and other students' frameworks
- c. *Creating conceptual conflict* by attempting to explain a discrepant event
- d. *Encouraging and guiding* accommodation and invention of a new conceptual model consistent with the accepted science view

### **Conflict between ideas.**

Sahin, (2010) studied the impact of problem-based learning on freshmen engineering students' beliefs about physics and physics learning (referred to as epistemological beliefs) and conceptual understanding of physics. The multiple-choice test of energy and momentum concepts and The analyses showed that the PBL group obtained significantly higher conceptual learning gains than the traditional group and the change (improvement) in the PBL group students' beliefs from the pre- to post test were significantly larger than that of the traditional group. The results revealed that beliefs were correlated with conceptual understanding. Suggestions are presented regarding the implementation of the approach.

Stavy (1991) draw attention to two types of framing of conflict between ideas. They are,

- a. A conflict between a child's cognitive structures related to a certain physical reality and the actual physical reality.
- b. A conflict between two different cognitive structures related to the same reality. They made use of second type of conflict in developing teaching strategy.

**Generative learning model.**

Generative learning model of teaching (Cosgrove and Osborne, 1985) has the following four steps.

- a. *Preliminary phase*: teacher needs to understand the scientists view, the children's view, his or her own view.
- b. *Focus phase*: opportunity for pupils to explore the content of the concept, preferably within a real everyday situation such that learners to engage in clarification of own views
- c. *Challenging phase*: learners debate the pros and cons of their current views with each other and the teacher introduces the science view
- d. *Application phase*: opportunities for application of new ideas across a range of contexts

**Dialogue based strategy.**

Dialogue based strategy (Champagne, Gunstone & Klopfer, 1985) otherwise described as ideational confrontation is specifically designed to alter student's declarative knowledge with in a particular domain. It involves following steps.

- a. *Students make explicit the notions* they use to explain, or make predictions about a common physical situation.
- b. Each *student develops an analysis* that supports his or her predictions and presents it to the class.

- c. Students' attempt to *convince each other of the validity* of their ideas, discussions and argument result in each student becoming explicitly aware of his or her ideas in that content.
- d. The *instructor demonstrates* the physical situation and presents a theoretical explanation using science concepts.
- e. Further discussions allow *students to compare their analyses with the scientific one*.

### **Resolution between ideas.**

Rowell and Dawson (1985) proposed a strategy in which resolution between students' prior ideas and new conceptions occurs after new conceptions have been introduced. The strategy that draws upon a perspective from the history and philosophy of science and equilibration theory (Piaget, 1977) is based upon the following two premises. 1) A theory is only replaced by a better theory and not discarded based on contradictory evidences, and 2) The construction of a better theory need not involve an immediate confrontation with the knowledge that an individual spontaneously considers relevant.

Although cognitive change involves both strategic and meta-strategic knowledge (Kuhn, 1963), they need not be constructed together. The teaching approach involves six steps.

- a. *The ideas which student consider* relevant to the problem situation are established.
- b. *Discussion and their ideas are retained in a 'paper memory'* for subsequent consideration.
- c. *Students are told that a theory is introduced* to them which may solve the problem and that their help will be required both in its construction and later in its evaluation against the alternatives they have proposed
- d. *The new theory is presented* by linking it to basic knowledge already available to the class

- e. *Students apply the new theory* to problem solution, in order to indicate its construction by individuals. Written work must a part of this procedure to provide a second paper memory for each student.
- f. *Each student compares the memories from step 1 and step 5* and the quality of the ideas is examined

### **Teaching Strategies Build on Pupils Existing Ideas**

#### **Analogy based teaching strategy.**

Analogical teaching strategy (Clement, Brown, & Zietsman, 1989) constitutes four steps.

- a. The student's *misconception* relating to the topic under consideration is made *explicit by using a target question*
- b. The instructor suggests a case which he or she views as analogous and which will appeal to the students intuitions. This case is termed as *anchoring example* or simply an anchor.
- c. The instructor asks the student to make an *explicit comparison between the anchor and target cases* in an attempt to establish the analogy relation
- d. If the student does not accept the analogy, the instructor then attempts to find a *bridging analogy* or a series of bridging analogies

#### **Method which scientists use.**

Niedderer (1987) put forwarded an approach based on the philosophy of science outlined by Brown (1977). It aims not to replace students' theories by scientific theory but allow them to arrive at a conscious knowledge of both. Solomon (1983) also has suggested learning scientific concepts by difference.

The strategy consists of six steps:

- a. *Preparation:* The teaching process that precedes the intervention, and may contain tools and concepts that may be drawn on.

- b. *Initiation*: an open-ended problem is posed
- c. *Performance* in following sequence. formulating questions or hypothesis, planning and performing experiments, making observations, theoretical discussions, and formulation of findings
- d. *Discussion of findings*: in a class forum
- e. *Comparison with science*: class findings are compared with similar historical theories or modern ideas. Differences are stated and possible reasons for those differences are discussed
- f. *Reflection*: students are encouraged to look back on the process of performance and to consider particular questions or difficulties which have arisen.

Keeping pupils alternative frame works in mind Driver (1978) suggested three points to be considered while planning classroom practice. 1) Curriculum development in physics needs to pay as much attention to the structure of thought of the child as it has recently paid to the structure of the discipline in organizing learning experiments. Currently scientist's concerns for the structure of thought of the child have been focused on Piagetian operations. It is argued that the content as much as the process of thought requires our attention. 2) Teaching programs need to be structured in keeping with the developmental path in understanding important scientific ideas. The logical order of teaching a topic may not correspond with the psychological order in learning .This is a word of caution for those who are enthusiastic about structured learning programmes that involve such hierarchies. 3) Activities in physics may need to include those that enable pupils to disprove alternative interpretations as well as affirm accepted ones.

### **Common Conceptual Change Strategies**

Since the mid - 1980's a number of researchers have focused on determining methods for changing students alternative conceptions in science. Some of these reviewed a number of studies in the field (Guzetti, Synder, Glass

& Gamar 1993; Wandersee, Mmtzel & Worak, 1994; Duit & Treagust 2003) and published a meta-analysis (Guzzetti *et. al.*, 1993) that has documented effectiveness of various conceptual change strategies at all grade levels. The strategies mentioned in this metal-analysis are: conceptual change text, refutation texts, concept maps, bridging analysis, computer simulation, demonstration, and computer aided instruction, and field trips.

### **Conceptual change texts.**

One of the common conceptual change strategies in this field is the use of conceptual change texts. (Wang & Andre 1991; Chambers & Andre, 1997; Tekkaya & Geban, 2001; Cakir, Uzuntryaki & Geban, 2002; and Tekkaya 2003).

Conceptual change texts are one of the strategies used to remove misconceptions. The conceptual change text strategy is designed in accord with a model of conceptual change to remediate misconceptions they are designed to make readers aware of the inadequacy of their intuitive ideas and create conceptual conflict described as a necessary requisite for conceptual change. They also help students understand and apply the target scientific concepts through the use of explanations and examples. The meaning of conceptual change oriented textual information is not derived wholly from the reading of the text but from the interaction of the reader with the textual information. The construction of meaning occurs when the textual information is concerned with and modifies the students existing knowledge. The modified prior knowledge is then used to direct subsequent learning. The textual information for causing better acquisition of scientific conceptions should enable students to progress at their own pace and force them to use their thinking ability.

Conceptual text was first proposed by Roth (1985). In Roth's model, the first step is to identify common misconceptions. Next a situation is presented to students to activate misconceptions. Then student's misconceptions are challenged by introducing common misconceptions followed by evidence that they are wrong. Finally, the correct scientific explanation is presented. Roth

(1985) reported that students using conceptual change texts performed better than those who receive traditional teaching approach.

Chambers and Andre (1997) listed steps for application of conceptual change texts in classrooms. They are

- (a) The instructional designer or teacher first identifies common alternative conceptions.
- (b) Students are asked to predict what would happen in a situation before they present the inconsistency between common non-scientific and scientific conceptions.
- (c) Common alternative conceptions are introduced with evidence that they are wrong and
- (d) Instruction presents the correct scientific explanation.

Bigozzi, (2014) studied a progressive-learning approach to physics, based on knowledge-building pedagogy, was compared to a content-centered approach in which explanations, experiments, and discussions are centered on the transmission of knowledge. The main conclusion achieved by this study is that the teaching of physics should be slow, cyclic, and developmentally appropriate for the context.

Armagan *et. al* (2010) conducted a study to determine the overall effectiveness of conceptual change texts on academic achievement and to find out if effectiveness was related to some characteristics of the study. It was found that conceptual change texts have been quite successful in promoting the students' academic success.

Sackes (2012) develop an instrument to assess college students' efficacy beliefs for conceptual change and to examine the psychometric properties of the instrument. The study reveals that the questionnaire appears to produce valid and reliable scores for college students. With the use of the questionnaire, conceptual

change researchers might be able to better assess the relationship between students' efficacy beliefs and the change in their conceptual understandings of various science concepts.

### **Refutational text.**

The refutational text approach has developed by Hynd and Alverman (1986) based on the conceptual change model for Posner *et. al* (1982). According to the researchers refutational texts are materials written to challenge and change students common non-scientific conceptions.

In this design common alternative conceptions are contrasted with scientific conceptions. However students are not asked to predict a common situation before refutation, in other words, the major difference between refutational text and conceptual change text is whether students are asked to predict a situation (Hynd, 2001).

Refutations involve analyzing statements about scientific ideas, process, or procedures that contain both accurate and incorrect information. Students make corrections to the statements so they are scientifically accurate and justify why they made the changes.

Refutation can be used prior to instruction to grab the learners attention and identify where students have strong or weak factual and conceptual knowledge related to a topic. This strategy can also be used to monitor student learning through instruction.

Commonly held ideas, including specific misconceptions, can be included in a refutation to help teachers identify students who may have similar ideas. If the teacher sees that these ideas go unnoticed in the refutation, this information can be used to design learning experiences that will confront students with their ideas and move them toward the scientifically accepted view. Justifications and corrections students make to the incorrect statement provide information to the

teacher on how students think about the content or procedures. Teachers may determine the need to revisit basic ideas and build upon them so that students develop understandings at a level of sophistication appropriate for their grade or developmental level.

Refutations are designed to address science content knowledge or procedures and results from a classroom inquiry – based investigations. They can be written as a story, article, or textbook-like passage. Refutations should be a reasonable length for both the content and the grade level of the students. Students can underline or highlight the areas of text they think need correcting, revise as necessary (individually or in groups), and justify their revisions. Engage the class in a whole-group discussion in which they justify why they think a statement is incorrect and what they would do to correct it.

### **Scientists ideas comparison.**

With scientists ideas comparison students are given a summary sheet of scientists' ideas, including appropriate terminology, related to a topic they have been studying. Students compare their existing ideas to the scientists, looking for differences and similarities.

Scientist's ideas comparison is used to help students make connections between the ideas they developed through a sequence of instruction and the formal, accepted scientific ideas. It provides a meta-cognitive opportunity for students to examine their thinking to see how close their ideas match the scientific ideas.

In this method prepare a summary list or paragraph of scientist's ideas. The scientists ideas are formal, scientific explanation of the concept or phenomenon written at a level students can understand at their grade level. Ask students to list their ideas about the concept or phenomena before giving them the scientist's ideas. Encourage students to list ideas that were developed during their discussions or class activities, citing where their ideas came from, or discuss

their ideas in response to an assessment probe. Alternatively keep a record of the class ideas noted throughout the instructional sequence, including class discussions, and provide students with this list. Use a valid reference source, teacher background information from instructional materials and explanations from the teacher notes, or consult with a scientist or science – content specialists to develop the scientist’s ideas. Provide students with the scientist’s ideas. Have students discussed in pairs or small groups how close they think their own ideas are to the scientists ideas. Engage students in a discussion about what they think it would take to help them more toward the scientist’s ideas. Use the feedback to design targeted learning opportunities that will move students closer to the scientific view or would improve opportunities to learn the next time the same lessons are used.

Mantyla (2012) studied the way to use the cognitive-historical approach for didactical purposes is introduced. In this application, the cognitive processes in the history of physics are combined with current physics knowledge in order to create a cognitive-historical reconstruction of a certain quantity or law for the needs of physics teacher education. The initial and final reports of twenty-four students were analyzed through a qualitative categorization of students’ justifications of knowledge. The results show a conceptual development in the students’ explanations and justifications of how the electromagnetic induction law can be formed.

Eshach (2010) the conceptual flow processes occurring in whole-class dialogic discussions with a high level of interanimation; in a high school class learning about image creation on plane mirrors. This model might help teachers to prepare and conduct efficient whole-class discussions which accord with the social constructivist perspective of learning.

### **Analogies**

The importance of analogies in science, mathematics, social studies, technology and literature lies in the ability to explain abstract ideas in familiar

terms. Teachers often say that an artery or vein is like a hose or tube; the earth is round like a ball; the eye works like a camera; and plants, animals and microorganisms are classified into functional groups, like the separate sections of fresh foods, canned foods, stationary and cleaning supplies in a sugar market. It is easy to see why analogies and models are important ways to describe and explain objects and processes, especially those that cannot be seen, like atoms and molecules.

In an analogy the everyday object, event or story that is well understood is called the analog, and the science concept to which it is compared is called the target. This terminology is itself a metaphor, like an analogy, because we all aim to reach targets; if we hit the target, we have succeeded. Explanations have aims so that when we understand the target it means you have achieved our aim.

The structural or functional links that can be made between the analog and the target are called ‘mappings’. Mapping can be

Positive: Having shared attributes – ways in which the target is like the analog.

Negative: having unshared attributes – ways in which the target is not like the analog.

Neutral: When it is not clear whether the target is or is not like the analog.

Teachers should always be sure of all the shared and unshared attributes for the analogies they plan to use with their students. Of course students can suggest their own analogies, and when this happens, some of the mappings are neutral and the challenge is to work out whether they are shared, unshared, or irrelevant. Many teachers skip this step saying that they short of time, but it’s important to help students make sense of their original ideas. These are the moments when students think creatively and such moments can be high points in their learning.

Most analogy researchers agree that analogies promote learning through a constructivist pathway (Duit, 1991). Constructivism claims that people have rich mental environments that are made up of familiar experiences and knowledge; interests, events, and stories; and their own ideas of what counts as evidence and knowledge. The degree to which a new concept fits this mental environment determines its fit. Whether it is accepted, modified, or rejected. Even young students have well developed ideas of how they think the world works, and childrens preconceptions can hinder learning in science. Ausubel (1968) pointed out that these preconceptions are amazingly tenacious and resilient to extinction. Research since that time has shown that student preconceptions are so strong that, in some cases, they are preserved in the face of obvious and contradictory evidence (Osborne & Freybay, 1985). Some students accept the teacher's science for the duration of the topic being studied and revert to their intuitive views following instruction. In other instances, students contrast separate schema to accommodate the lesson content without altering their preconceived views.

Both preconceptions and learned misconceptions resist conceptual change (Nussbaum & Novicle, 1982). Some teachers find this worrying but the strength of all types of student conceptions means that acceptable conceptions, once learned, are robust and long lasting. Using analogies to learn science can be describe as conceptual growth (the expansion of acceptable student conceptions) or conceptual change (revision of existing unscientific conceptions) or both.

Most of the studies into conceptual change and learning with analogies were based, at least in part, on Piagetian theories. Since the 1980's researchers have interpreted learning with analogies using Piaget's equilibrium concepts, Vygotsky's zone if proximal development, Ausubel's meaningful learning and social constructivist viewpoints. While most studies of analogy claim to be constructivist few explicitly tie their theory and methods to theorists like Piaget and Vygotsky.

Piaget's stage development ideas suggest that younger children will benefit most from concrete analogies, analogs they can see and feel. It is reasonable to expect that the abstract thinking that emerges in Grades 8-10 will enhance the effectiveness of verbal and abstract analogies with older students who have begun to master mental models. Teachers should be cautious when using abstract analogies, as even some older students may not possess the necessary visualization skills. This is why teachers must ensure that their students understand the everyday object or experience that is the basis for the analogy. Vygotsky theory recommends locating the analog in the student's zone of proximal development. Knowledgeable peers (other students) and adults (teachers) provide the 'need to know' information that helps the student to correctly map the similarities and differences between the everyday analog experience and the target concept. Peers and teachers provide the knowledge that can be processed by the learner but is not yet known by the learner. As constructivists point out, it is the student who ultimately has to see and understand the shared analog-target attributes that lead to conceptual growth. Learning is the personal construction of new knowledge or the restructuring of old knowledge. Analogies help students learn and remember scientific ideas. Analogies also are powerful inquiry tools because they suggest new questions, relationships and investigations.

Teachers who are aware of important and common alternative conceptions often resort to analogies because they realize that it is much easier for students to accept a scientific idea if it is against with something they already understand and accept.

### **The participative approach.**

Participative theories of learning (eg: Vygotsky, social constructivism) that view learning as a process that involves a community of learners in an ongoing discourse, seem to be more suitable for grasping "process". The participatory approach focuses on the dialogical interaction between "the outer"

(the social context) and “the inner” (the individual learner) interacting to construct meaning (Marton & Booth, 1997). The established partnership among the members of the community is geared towards constructing common meaning. The situatedness in the social - cultural specific context is leading to the emergence of meaning-knowledge that is appropriate to “here and now”. The nature of the discourse that is the major tool in the process cannot be predetermined (Gedamar, 1990). Rather, it emerges in the process of conversing and unfolds the reciprocal interactions among the involved persons. The group members open themselves to other and at the same time open the possibility of affecting their understanding of the world. This idea of the group discourse leads to collective new understandings has been described as structural coupling or “co-emergence” Sumara (1997). Knowledge, within this approach is understood in terms of what emerges from the continuous discourse and reciprocally fuels that process of learning to go on.

### **Anchoring conceptions.**

Student’s preconceptions often pose strong barriers to understanding physics. However, although many preconceptions are detrimental to learning, there may be other preconceptions that are largely in agreement with accepted physical theory. These concepts referred as anchoring conceptions or more briefly as anchors.

We assume that it is desirable to be able to ground new material in that portion of the student’s intuition that is in agreement with accepted theory. It should help students to understand and believe physical principles at a make sense level instead of only at a more formal level. For example, many students refuse to believe that static objects can exert force .They refuses to believe the physicist assertion that a table exerts an upward force on a coffee cup on the table. How ever almost all students believes that a spring will exert a constant force on ones hand as one holds it compressed. In teaching that inanimate objects can exert forces, this intuition about springs can be built on as anchor. By

working with students to help them see that even rigid objects are springy to some extent, one can anchor the idea of static force in the student's intuitive conception of springiness.

In theoretical terms we define an anchoring conceptions an intuitive knowledge structure that is in rough agreement with accepted physical theory. By intuitive, it is mean that it is concrete rather than abstract, and in particular that is self evaluated; the strength of the belief is determined by the subjects themselves rather than by appeal to authority.

Individual anchors: a problem was considered to be an anchoring example for an individual student if he or she gave the correct answer and indicated a confidence interval greater than or equal to on the confidence scale. Perhaps such an example should actually be called a potential anchor, not all anchoring examples defined in this way can be used effectively in instruction via transfer. Thus in some context it may be useful to split the concept of anchoring example as follows: potential anchors are anchoring examples that can be extended in instruction so that a useful anchoring conception is transferred to other more difficult target situations.

Group anchors: a particular example is an anchoring example for a group as well as for a particular student.

This teaching strategy starts from student's correct ideas. Many ideas in physics are counterintuitive therefore students don't accept them easily. This strategy builds on students existing ideas by forming analogy relations between a misunderstood target case and an "anchoring example" which draws up on intuitive knowledge held by students (Clement, Brown& Zeitsman, 1989). Anchoring conceptions are student ideas that are roughly from physics point of view, and can serve as analogies with counterintuitive target conceptions. They represent a good unproblematic starting point for thinking about a certain phenomenon.

If the analogy between the anchoring conceptions and target conceptions does not work immediately, additional bridging analogies are introduced, that lead the student to target conception.

### **Concept mapping.**

Concept mapping is a graphic technique for representing ideas, helping to think, solving a problem, planning a strategy or developing a process. Concept mapping means connecting different concept of the subject and constructing relations by compiling the map.

The concept mapping method is based on the theory of meaningful learning (Ausebal 1963) and on the assumption that knowledge saved in the human brain propositionally and the generated concept maps just represent this propositional knowledge saved in the brain Atkinson, shiffrin, Norman, Rumelhart (1978).

The method was introduced in didactics by the American scientist (Novak 1990). Later on analogous methods have been developed by several research groups. Much success has been achieved by the application of concept mapping in the technique process to integrate new concepts into the existing system of knowledge (Novak 1990).

Concept mapping is a process of meaning making it implies taking a list of concepts- a concept being a perceived regularity in events or objects, or records of events or objects, designated by a label – and organizing it in a graphical representation where pairs of concepts and linking phrases from proportions. Hence, key to the construction of a concept map is the set of concepts on which it is based.

Borreguero, *et. al* (2013) studied effectiveness of concept mapping on remediation of misconcepts and found that concept maps are learning tools

which foster conceptual change and allow misconceptions to be eradicated via meaningful learning maintained over time.

### **Computer simulations.**

Computer based labs and especially simulations because of their time efficiency, allow students to ask “what-if questions” (Carlsen & Andre, 1992; Coleman, 1997). When students have the freedom to ask such questions and receive near immediate (real time) feedback they are accessing a powerful tool for conceptual change (Hennesy *et. al*, 1995). Computers take the drudgery out of science activities and thus encourage students to take part in science fairs and similar learning experiences (Hasson & Bug, 1995; Kelly & Crawford 1996). The immediate feedback possible with microcomputer based labs allows learners to focus on conceptual goals (Mestre & Touger, 1989; Stein, 1987). Dykstra, Boyle and Monarch (1992) also support microcomputer based labs as a tool for teaching conceptual change. Well designed instructional provisions such as structured handouts are used to guide discovery and to keep students on task thereby ensuring the success of such activities (Stein, 1987).

Computer simulations run within a constructivist classroom will bring the students to question their own conceptions (Dykstra, Boyle and Monarch, 1992). These simulations provide the learner with a range of learning experiences (Tao & Gunstone, 1999). Commercially available computer simulations help students avoid forming misconceptions (Coleman, 1997) and can be used to challenge student conceptions through the presentation of discrepant events (Tao & Gunstone, 1999). Computer-based labs have also demonstrated the ability to promote proper conceptual development through activity-based learning (Dykstra, Boyle & Monarch, 1992). Simulations can help students learn about the natural world by having them see and interact with underlying scientific models that are not readily inferred from first hand observations. (Krajcik & Lunetta, 1987; Dykstra, Boyle & Monarch, 1992). Martinez-Jimenez *et. al*

(1997) claimed that the students who used interactive physics simulations received better marks in freshman physics courses. This follows constructivist model closely as students are building their understanding through their interaction with these learning activities. When the learner poses a conjecture to the computer the simulation system provides a response from which the student can draw a conclusion. Over time, this leads to concept development. Stein (1987) made several observations of students developing acceptable conclusions using microcomputer-based labs. Sornkhatha,P & Srisawasdi,N. (2012) done a study using computer simulation on Newton's law of motion and found effective as a conceptual change strategy.

### **Studies on Misconcepts in Physics**

Studies reviewed has highlighted several content areas in Physics where identifiable misconceptions exist and which make obstacles in the way of physics learning and teaching field; the studies reviewed are presented under respective areas.

#### **Studies on Identification of Areas where Misconceptions Occur**

The studies below are divided into specific content areas and overlapping subcategories according to their main emphasis.

##### **Matter.**

In science the word material is used to designate any kind of matter or stuff that can be observed or detected in the world around us, children may initially use the word to mean those things that are required to make objects- for example, fabric for clothing or bricks for buildings. Bouma *et. al* (1990) studied the meanings pupils gave to the word matter, they show that at age 13 only 20 percent of pupils explained it as something that could be handled and takes up space. The reminder either gave the word a non tangible meaning, no explanation

or confused one. These researchers also found that pupils' first meaning of the word material was a fabric for making cloths. Other meanings offered included drawing materials and building materials

Several studies of pupil's initial conception of an atom show that they perceive it either as a small piece of material or as the ultimate bit of material obtained when a portion of material is progressively sub divided (Ben-zvi, Elyon, & Silberstein, 1986; Holding, 1987; Pfundit, 1981) such bits are thought to vary in size and shape, to have no space between them, and to possess properties similar to the parent material. Thus for instance, children frequently consider atoms of a solid to have all or most of the macro properties that they associate with the solid. Consequently, children often attribute to atoms properties such as hardness, hotness, color and physical state. Their views contrast with a school science one of atoms as the performed building blocks of material science.

Several researchers (Brook, Driver, R, 1989; Sere, 1985, 1986; Mas, 1986; Piaget, 1973; Stavy, 1988) have studied pupils conceptions of gas and found that they do not appear initially to be aware that air and other gases possess material character. Although young children may have said that air and smoke exist, they do they regard gases as materials as having transient character similar to that of thoughts. In many children thinking, air and gas appear to have contrasting affective connotations: air is good and it is used for breathing and for life; gas is bad because it may be poisonous, dangerous or inflammable. Later pupils develop an awareness of the material character of gases. They come to regard gases as materials which spread and they recognize that some gases can be even though most are colorless, odorless and transparent. However, pupils may not regard gas as having weight or mass, Leboutet and Barrell (1976) suggests that this is because children's most common related experience is that gases tend to rise or float. This view is supported by studies which show that children aged 9- 13 tend to predict that gases have the property of negative

weight and hence that the more gas that is added to a container, the lighter the container becomes (Brook, Driver, R, 1989; Stavy, 1988). Until they construct the idea that gases have mass, pupils are likely to conserve mass when describing chemical changes that involve gases as either reactants or products (Mas, 1986).

Several researchers' studies of particle ideas concerning the gaseous state, held by students and teachers, have been reported (Dow, auld & Wilson, 1978; Novick, & Nussbaum, 1978; Driver, 1983; Gabel, & Samuel, 1987) Novick and Nausbaum studied conception of gaseous state held by 13 to 14 year olds who had already been instructed in the particulate theory of matter. About 60 percent of the sample population indicated that gas is composed of particles; and 50 percent said that intrinsic motion accounts for the distribution of particles in space. These researchers report a similar study of older students and they propose the use of a conceptual conflict based teaching strategy for particulate theory (Nussbaum & Novick; 1885)

### **Air pressure.**

Working with 12- 14- 16 year olds, Engel clough and driver found high percentages (67 %, 80%, and 87% respectively) thinking that increases with depth .however, pupils were less inclined to think in terms of pressure acting equally in all directions, they were inclined to think of a greater pressure downwards students understanding of atmospheric pressure were reported by (Brook and Driver 1989; Engel Clough & Driver, 1985) the former study reports that questions involving atmospheric pressure explanations appeared difficult for pupils to answer, most students referred only two events inside the containers, in terms either of a vacuum sucking or of pressure inside pulling. A difference was noted, however between phenomena where atmospheric pressure was greater than the pressure inside the container and phenomena where pressure inside the container was greater.

### **Horizontal motions.**

Students' understanding of motion (including horizontal motion) has been the subject of considerable research in many countries through the world. This area of science has been of particular interest because of the difficulties which learners of all ages seem to have in grasping the physicist's Newtonian view of motion.

Commonly occurring prior ideas about motion include the notions that if an object is pushed. With a constant force this produces constant motion; and that if the pushing force ceases there is a force in the moving about which keeps it going but which gradually gets used up and then the objects stops.

The extent to which student's ideas about motion are coherent and theory like is a matter of dispute. Some researchers comment on the adhoc and context dependent nature of students reasoning (McClelland (1984), Yates (1988) Di sessa (1982). Others argue that there are underlying consistent forms of reasoning about motion which can be identified. (Ogborn (1982), McCloskey (1983), Clement (1983)).

It is clear that understanding motion in Newtonian terms (in which motion at a constant velocity needs no causal explanation, and in which acceleration is the result of net force) is a major task for pupils. Students of all ages, including physics undergraduates fail to grasp the Newtonian conception of motion (Jung 1981), they modify rather than abandon their gut and lay dynamics and merely attach new labels to their own theories, (Jira (1980). In particular, it appears from the work of many researchers that learners do not easily share the physicist's commitment to consistency of explanation in the form of a coherent framework they may hold independent and even conflicting ideas about related phenomena.

Children's ideas and descriptions of motion tend to be less differentiated than physicists. They tend to see objects as either at rest or moving. The period of change, when for example on object speeds up from rest to a steady speed or

slows down and stops, is less frequently focused on by children. The term acceleration is not commonly used by school-age pupils prior to its introduction in science lessons. Everyday terms such as going faster are used in ambiguous ways, sometimes referring to the magnitude of the speed of an object and at other times referring to the speed increasing with time. There are many studies which report such problems.

Jung (1981) reports pupils leaving time out of their thinking such that they were imagining an object getting to certain or being set into motion rather than accelerating over a period of time. Among some 300 university students only 40 percent successfully compared the acceleration of objects Trowbridge, (1981) and only 68 percent of sample of fifty-two 17 year olds studying physics recognized that an overtaking object is going faster all the time.

It is common for pupils to think that, if speed is increasing, then acceleration is also increasing. This was the case for 60 per cent of the fifty-two sixth formers taking physics, and it was the case for 88 per cent of a group of 113 pupils aged 12-14. Who were studied by Jones (1983).

### **Mechanics.**

The dominant topic over the past two decades, within the field of misconceptions in physics has been mechanics i.e. motion, force, vectors etc. The largest numbers of studies completed on misconceptions in physics have focused on students' comprehension of forces and Kinematics (Wandersee & Novak, 1994). This is not surprising given the amount of time spent on mechanics in introductory physics curricula in high school and first year university programmes. What may be surprising is despite the amount of time spent on mechanics how tightly high school students cling to Aristotelian and impetus based theories of motion (Mintis & Novak, 1994). Many of these incorrect conceptions about basic ideas of force and motion come from the students intuitive interaction with their environment but often are not 'un-learned' in the physics classroom.

### **Forces.**

The development of ideas about forces, often take place in the context of learning about horizontal motion or about gravity and falling. Consequently a lot of the research into pupils thinking about forces relates to these domains.

Some studies, including a developmental study by Piaget have explored pupil's ideas about forces themselves and how they act.

Underlying pupils ideas about practical experiences of forces are their understandings about the way forces are transmitted through solids, liquids and gases – understandings which also underpin their ideas about pressure. Students do not appear to have focused upon ideas about the transmission of forces but there has been some work focusing on pupils ideas about pressure.

Pupil's ideas about the nature of forces have been identified from the very substantial body of research into understanding about motion. Younger pupils, between 7 and 9 years, were found to think of force in terms of anger or feeling Osborne (1985). Yet, at the same time, some 7 and 8 year old held the physicists view of force as something cutting to cause a change in motion, although they tended to talk to force getting things going rather than making things stop.

Pupils naturally bring to their learning lay meanings of the word force and many studies have reported the word being associated with living things. Gunstone (1985) found that pupils associating forces with physical activity and muscular strength. When pupils do think of inanimate objects as having or exerting forces, they appear to focus on those objects which can cause things to move and so can be regarded as agents not unlike living things Watts (1983). Pupils sometimes suggest, when describing the action of forces that objects are trying to bring about a particular motion.

Many researchers have found that pupils associate forces only with movement, not recognizing the passive forces involved in equilibrium situations. Driver (1984) reports that pupils are reluctant to accept the presence of force

where there is no motion and a study of 1000 Norwegian upper secondary students supported this finding Sjoberg (1981). About fifty percent of the sample not recognizing such passive forces.

Research shows a widely held view that there is something often called 'force' within a moving objects (Viennot, Clement, (1982), Mcdoskey 1983). This force is thought of as keeping the object moving and it appears to have something in common with physicists' momentum. Moving objects are thought to stop when the force of motion in than runs out something like fuel getting used up.

Studies of pupil's ideas about the relationship between force and motion have identified the following main ideas:

- If there is motion, there is force acting.
- If there is no motion, then there is no force acting
- There cannot be a force without motion
- When an object is moving, there is a force in the direction of its motion.
- A moving object stops when its force is used up.
- A moving object has a force within it which keeps it going.
- Motion is proportional to the force acting.
- A constant speed results from a constant force.

Learners generally to think of forces as a property of a single object rather than as a feature of interactions between two objects and this is reflected in Brown and Uanents (1987) studies as well as in those of Maloney (1985), Minstrell and Stimpson (1986) found that pupils think of weight, motion, activity and strength as being important in determining an object's force. Pupils inclination to think in terms of force as a property of an objects leads several researchers to propose introducing the word 'momentum' for this, recognizing that in the early secondary years this would mean only a quantitative, intuitive understanding of the term. It is argued that this is readily accepted by younger

pupils and it allows them to think about the meaning of force without wanting to attribute it as a property of a single object.

Several researchers stress the importance of paying more attention to Newton's third law, in order to help pupils appreciate that a force is not a property of an object but forces are characteristics of action between objects. Given pupils difficulties in recognizing a force of reaction, Minstrell (1986) proposes offering 'bridges' between prior ideas and science ideas. For example, pupils who did not recognize a reaction between a table and a book resting upon it were led through thinking about a book resting on an outstretched hand, a book resting on a spring and a book on a springy plank, back to a consideration of the book on a table. Such bridging strategies have been found effective in a number of different contexts.

The references below are divided into overlapping subcategories according to their main emphasis (2) Kinematics (3) Dynamics and (4) relativity and frames of references.

### **Kinematics.**

In the following papers, the authors identify and analyse specific difficulties that students have with the kinematical concepts and their graphical representations, and with the relationship of concepts and graphs to real world.

"Investigation of student understanding of the concept of velocity in one dimension" Trowbridge and Mcdermott (1980).

"Investigation to student understanding of the concept of Acceleration is one dimension" Trowbridge and Mcdermott (1981).

The two papers above report on an investigation of student understanding of the concepts of position, velocity and acceleration. Individual demonstration, interviews conducted with 200 university students, indicated that even after instruction many students confused position with velocity and velocity with acceleration.

“Even honours students have conceptual difficulties with physics”, Peters (1981) found a variety of conceptual difficulties among students in an introductory honours physics course. Although mostly about kinematics, the discussion include dynamics, electricity and magnets.

Aguirre (1988) in his paper, student preconceptions about vector kinematics “discussed student difficulties with vector kinematics”.

Mcdermott and Vanzee (1987) had done a study “student’s difficulties in connecting graphs and physics: Examples from Kinematics”. A long-term study involving several hundred students helped identify student’s difficulties in relating kinematical concepts, their graphical representations, and the motion of real objects.

Goldberg and Anderson (1989) has done a study by the help of interviews and written tests at four universities probed student understanding of negative velocity and found many difficulties with graphical representation of negative values of velocity.

### **Dynamics.**

The references below focus on the identification of student difficulties with dynamics including Newton’s laws, Circular Motion and the concept of energy and momentum.

Viennot (1979) done an instigation conducted among European students drawn from the last years of secondary school through the third year of university. The students demonstrated a strong tendency to assume a direct linear relationship between force and velocity.

Champagne and Anderson (1980) conducted a test on more than 100 students in an introductory university course on force and motion prior to instruction. Many non-Newtonian ideas were observed, including a constant

force produces constant velocity and in the absence of force, objects are either at rest or slowing down.

Mecloskey and Green (1980) conducted a study on university students. The students were asked to predict the motions of objects moving in constrained curved path. Many believed that an object would “remember” the curve after it left the constraint.

Caramazza and Green (1981) conducted a study on 50 students about misconception in trajectories of objects. Here students were asked to trace the path of a pendulum bob if the string were cut at different positions along its path, only about one-fourth responded correctly.

Gunstone and White (1981) done a study on understanding of gravity by simple lecture demonstration shown to several hundred first year university students in Australia. The students exhibited a strong tendency to observe their prediction regardless of what actually happened.

Clement (1982) done a study on students preconceptions in introductory mechanics. The result of the study indicates that many students believe that motion implies a force, both before and after the study of introductory mechanics.

Maloney (1984) conducted a study on Newtons third law with more than 100 university students with different back grounds in physics. They were asked to compare the forces that two interacting objects exerted on each other. About two-thirds thought that they would be of different magnitude in some circumstances.

Lanwson and McDermott (1987) conducted a study after instruction on the work, energy and impulse – momentum theorems. Most students were unable to relate the algebraic formalism to motions that they observed.

Boyle and Maloney (1991) had done a study on effect of written text on usage of Newtons third law. They examined the beliefs about Newtons third law

of 100 university students before instruction. Half of the students were given a handout describing force with explicit statements of the third law no student without the handout applied the third law correctly and of those with the handout, fewer than half applied it correctly.

### **Mass.**

Researchers have found that, from an early age, children notice how objects differ in the way they appear to press down on the hands shoulder or head they learn to feel the weight of objects. Children compare objects by their felt weight over time, generate an idea that felt weight is a characteristic property of an object (holding; 1987; Mullet & Gervais, 1990). Holding (1987) investigated the development of an idea of an object being pulled down by a force (rather than actually pressing downwards), and also the development of the concept of mass. Both conceptual changes appeared to be developing slowly. Mass often becomes associated with size or volume. In that event pupils often estimated the mass of material from its bulk appearance.

### **Relativity and frames of references.**

Saltiel and Malgrange (1980) conducted a study on 700 university students about spontaneous ways of reasoning in elementary kinematics and identified student difficulties with relative motion and reference frames.

Panse and Kumar (1994), Ramadas and Kumar (1996), Ramadas and Kumar (1998). The three papers above describe a series of studies in which undergraduate students in India were asked questions about transformations between different frames both kinematical and dynamical issues were considered and student responses classified.

### **Electricity.**

Most pupils' introduction to learning about electricity the world over involves using a battery, wire and a 1.25v bulb to make the bulb light. Pupils

generally tackle this with enthusiasm and also with certain established ideas about both batteries and bulb work, several researchers Shipstone, (1984), Tiberghien (1983), Osborne (1981) have investigated pupils' earliest ideas about electricity and they report that these ideas generally indicate a source – consumer model in which the battery gives something to the bulb.

### **Pupils ideas about a simple circuit.**

Solomn *et. al* (1985) and Licht (1985) have pointed to the importance of pupils' background awareness of, and interest in electricity. Licht found among 207 pupils studied, that danger/safety and video apparatus and electronics were the contexts in which pupils were most interested this of course leaves the teacher with the difficult task of maintaining pupils' interest in the modest DC circuits which will help them to begin to understand the phenomena. The models which are used by children to explain the phenomenon of a simple circuit have been studied in several countries: New Zealand, Australia, the USA, Sweden, Greece, France and Germany as well as the UK. Osborne and Freyberg's (1985) work in New Zealand identified four explanatory models which have since been found by other researchers world-wide some of these alternative models are very firmly held, not only by young pupils but by physics and engineering students who are regularly involved in practical work and calculations relating to circuits.

In the first of these models, here pupils regard only one wire as active and, whilst most come to recognize the practical requirement for a complete circuit, they nevertheless think that the second wire doesn't play an active part. It is sometimes regarded as a safety wire.

In the second model pupils think of current flow from both terminals of the battery to the bulb. They sometimes explain the light in terms of the clash of the two currents.

In the third model current is seen as 'used up' by the bulb and so there is less in the wire 'going back' to the battery. Some pupils expect a second bulb to

be less bright than the first when two bulbs are in the circuit: Others imagine components' sharing the current is used up by the bulbs.

The fourth model shows the magnitude or value of the current unchanged in the return wire.

It is notable that all the prevalent alternative models are sequential models in which something from the battery travels around the circuit, meeting wires and components in sequence. This deep seated notion, with its roots in the cause and effect everyday experience of other phenomena, underlies many of the problems which pupils have in understanding the behavior of electrical circuits. It is the notion which might be considered as the underlying mental model having various expressions.

In their earliest experience of batteries pupils often think of battery as a unipolar giver of electricity. It seems that pupils generally think of the battery as storage of electricity or energy. They see it as delivering a constant current in a closed circuit, rather than maintaining a constant voltage or potential difference. Indeed, pupils have very little notion of voltage or potential difference and the battery was seen as storing a certain amount of electricity by 85 percent of a group of 400 German secondary students (Maichle, 1981).

Current is usually introduced to pupils as the primary concept and they tend to think of voltage as a property of the current rather than as a precondition for a current flow (Von Rhoneck, 1984). It follows that pupils expect voltage to increase as current increases. They are very reluctant to believe that if no current flowing, there can still be a voltage between two points plenty of experience is advised, with both ammeters and voltmeters in simple circuits, in order to erode the voltage equals current idea. Pupils tend to start with one concept for electricity in a direct current circuit, a concept labeled current or energy or electricity all inter changeable and having the properties of movement, storability and consumption (Shipstone, 1984; Psillos; Koumaras;& Tiberghien 1988).

Understanding an electrical circuit involves first differentiating the concepts of current, voltage and energy before relating them as a system, which the energy transfer depends up on current, time and the potential difference of the battery. the notion of current flowing in the circuit is one which pupils often meet in their introduction to a circuit and because this relates well with their intuitive notions, this concept then becomes the primary concept (Cohen; Eylon & Ganiel; 1983). The result of this tends to be that when voltage is introduced it is seen as a property of current. Psillos *et. al* point to the need for particular effort to introduce voltage initially as a property of the battery, a precondition for current to flow and present even when no current is flowing. In this it could more easily be differentiated from current.

Von Rhoneck (1981) found in a group of thirteen pupils that eight of them thought of voltage as a force and that all thirteen of them thought of current as energy. Clearly pupil's notions of the relationship between force and energy can have bearing on their views of electrical energy. The earliest idea of resistance is of a hindrance- a barrier to the flow of charge. Shipstone explains how pupils think of resistance affecting only parts of the circuit downstream coupling their idea of hindrance with the notion of the sequential circuit in which the current is influenced by each circuit element in turn.

### **Electricity and magnetism.**

Students misunderstanding of concepts in electricity and magnetism has not been investigated in as great detail as in mechanics. Public articles on student difficulties have dealt primarily with two topics: DC circuits and electric fields.

Fredette and Clement (1981) conducted a study on simple electric circuits and also Fredette and Lachhed (1980) done same sort of study and these two discusses the responses of college students to the task “combine a battery bulb and one wire to make the bulb light”.

Cohen and Ganid (1983) conducted a study on potential difference and current in simple circuits and analysed responses from multiple-choice test given to 145 high school students and 21 in-service physics teachers in Israel although the teachers did better than the students many had similar conceptual difficulties.

Dupin and Joshua (1987) had done a study in France about conceptions of French pupils concerning electric circuit which is held by students ranging in age from 12 to 22 years. It was found that some simple misconceptions disappear with instruction, but teaching seems to have little effect on others.

Shipstone and Rhoneck (1988) conducted a study on students understanding of electricity in five European countries and revealed substantially the same difficulties everywhere.

Heller and Finely (1992) conducted a study on variable uses of alternative conceptions. Fourteen in-service elementary and middle school teachers were found to have a coherent but incorrect, model of current.

McDermottee and Shaffer (1993) conducted a study on introductory electricity. This paper identifies specific difficulties that may undergraduate students have with DC circuits.

### **Electric and magnetic field.**

Since many of the basic concepts in electricity and magnetism are not familiar from direct experience and are quite abstract, students can be expected to have conceptual difficulties. The few published studies are quite provocative, but far from complete.

Ferguson and Jokes (1981) conducted a study on the quality of knowledge in the field of electricity and magnetism. The authors investigated how first-year university students organized their knowledge of electromagnetism. Successful problem solvers had a more coherent knowledge structure.

McMillian and Swadener (1991) conducted a study on novice use of qualitative versus quantitative problem solving in electrostatics. Six students in a calculus based physics class were observed as they solved electrostatics problems. The successful students differed from the others only in mathematical facility, not in qualitative understanding. Both groups had difficulty with qualitative questions and had similar misconceptions.

Viennot and Rainson (1992) conducted a study of the difficulties of French and Algerian university students with Gauss's law and with electric field in an insulator.

Tornkvist and Transtormer (1993) conducted a study about comprehension of the electric field concept. Analysis of more than 500 written responses and nearly 100 interviews revealed difficulties with the concept of electric field lines among second-year students at the Royal Institute of Technology in Stockholm.

Galil (1995) conducted a study on mechanics background influence on students conceptions in electromagnetism. Difficulties with electromagnetism were identified in a study that included 10<sup>th</sup> graders and pre-service technology teachers in Israel.

### **Electrostatics and magnetostatics.**

In contrast to other topics of physics, students' misconceptions and conceptual difficulties related to static electricity has not been researched deeply yet (Guruswamy *et. al.*, 1997). Maloney *et. al.* (1985) noted that developing instruments to assess student ideas in electricity and magnetism is a very different task than other areas of physics. Since electricity is very common in everyday situations, it is natural that students (and also adults) have many misconceptions about electricity (Caillot & Xuan, 1993). Although almost all books start to discuss electricity with the concept of electric charge, students do not have a clear understanding of charge concept (Eylon & Ganiel, 1990; Galili

1993; Guruswamy *et. al.*, 1997; Thacker *et. al.*, 1999). Students' typical concept is that 'a neutral object has no charge' (Calilot & Xuan, 1993; Thacker *et. al.*, 1999). Another common misconception about the concept of electric charge is that 'a charged body contains only either electrons or protons' (Siegel & Lee, 2001). Students have many difficulties about the concept of static electricity. Many students and also adults think that 'friction is the cause of static electricity' (Calilot & Xuan, 1993; Siegel Lee, 2001). Researches on students' misconceptions in electrostatics are mainly focused on electric fields and forces exerted by electric fields on charges (Eylon & Ganiel, 1990; McMillan & Swadener, 1991; Galili, 1993; Törnkvist *et. al.*, 1993; Rainson *et. al.*, 1994; Furio & Guisasla, 1998; Savelsberg *et. al.*, 2002). The findings of these researches showed that most of the students do not have clear understanding of the concept of electric field and hence held different misconceptions. For example, students have difficulties about representation of electric field lines. Galili (1993) found that according to students, electric field lines are real. Besides, Törnkvist (1993) found that students think that electric field lines can both cross each other or make sharp boundaries and force exerted on a charge on the field line is along the field line. Some other misconceptions are 'field lines can begin/ and end anywhere' and 'there are a finite number of field lines' (Rainson *et. al.*, 1994; Maloney *et. al.*, 2001). Guruswamy *et. al.* (1997) showed that students have many difficulties concerning charge transfer. Examples can be given as 'there is no transfer of charge between two metal objects with charges of the same sign', 'transfer between oppositely charged metal objects occurs until one of the objects is neutral', 'there is no transfer between a charged metal object and a neutral metal object', and 'the charges on the two metal objects remain the same after touching regardless of the signs of the initial charges'. Calilot and Xuan (1993) discussed that similar misconceptions are held by adults. Students also have many conceptual misunderstandings about concepts of potential, potential difference and capacitance (Thacker *et. al.*, 1999). For example, 'charges jump from one plate of the capacitor to the other', 'parallel plate

capacitors store a net charge', students do not know what is meant by net charge, 'parallel plate capacitors store voltage', and students do not know what a capacitor is (Beatty, 1996).

Simanek (2002) observed that sometimes textbooks may lead to misconceptions with inappropriate definitions (Sanger & Greenbowe, 1999). When investigated, there are phrases like 'capacitor is a device for storing charge' in some textbooks (Jones & Childers, 1992; Ohanian, 1989). This may cause students to think that 'there is a net charge on a parallel plate capacitor when it is charged'. Capacitance is the ability of a component to store charge. But this can be misleading unless it is explained clearly. The total charge at all times on a parallel plate capacitor is zero; when it is charged, it holds equal amounts of positive and negative charges (Ellse & Honeywill, 2001).

Misconceptions are very stable and traditional instruction does not encourage meaningful learning hence it is not easy to replace them with scientific conceptions (Hestenes, 1987; Clement, 1993; Novak, 2002). Changing misconceptions is not simply adding new information to an individual's mind, but care should be taken to account for the interaction of new knowledge with existing provided that the new may be replaced with the existing (Hewson & Hewson, 1983). Replacing the existing faulty knowledge with the scientific one is one of the aims of conceptual change strategies (Posner *et. al.*, 1982; Hewson & Hewson, 1983; Novak, 2002). Many researches about students' misconceptions in science stated that traditional instruction (transfer of knowledge) is ineffective on correcting misconceptions and does not usually result in meaningful learning (e.g. Hestenes, 1987; Mestre, 1991; Dykstra *et. al.*, 1992; McDermot & Shaffer, 1992; White, 1992). Furthermore, all state that most of students' misconceptions exist after instruction. It is not easy to change students' beliefs. After the instruction students might use scientific knowledge in school, and give correct answers to standard questions, but in unfamiliar situations or outside the school will use their own alternative beliefs (White, 1992).

Maloney (1985) conducted a study on charged poles in an algebra based physics class and strongly suggest that even after instruction many students are confused about interactions between electric charges and magnetic poles.

Guruswami and Hussy (1997) conducted a study on students' understandings of the transfer of charge between conductors. Individual demonstration interviews were used to investigate students' understanding of charge and behaviour of charged conductors. After instruction few students were able to identify the forces of a charge on a conductor or to describe how charges were shared between touching conductors.

### **Magnetism and gravity.**

Relatively little research has been published in relation to children's ideas about magnetism, although some studies of ideas about gravity have touched upon it. Researchers studying ideas about gravity have found that pupils are inclined to link magnetism with gravity. They sometimes account for gravity in terms of a magnetic force drawing objects towards the earth Bar (1987). Conversely; pupils have been found to account for the way magnets act by calling magnetism a type of gravity Barrow (1987).

Given that pupils tend to link magnetism with gravity and given that pupils also tend to link gravity with the effects of air, Bar and Zinn (1989) looked for pupils' ideas suggesting a link between magnetism and air among the 9 – 14 age group. These researchers found 40 per cent of their sample of ninety-eight pupils considering that a conducting medium (air) is necessary for a magnet to have an effect. A connection between magnetism and gravity has made by 20 per cent of the sample.

Barrow (1984) investigated awareness of magnets and magnetism among seventy-eight pupils across all age ranges. All were well aware of magnets in their everyday experience, in picking up nails or pins or in sticking notices to refrigerators. Before teaching, most pupils offered no explanation of magnetism.

A few referred to chemicals making them stick. After teaching, references were made to a type of gravity, to energies and to electrons and protons. Less than 10 per cent of the sample appeared to have the idea of poles, although approximately 25 per cent responded accurately when tested on attraction and repulsion of poles. However, pupils tended to think of poles only at the ends of magnets and Barrow suggests that pupils might be encouraged to focus on the magnetic force and find the part of the magnet where attraction and repulsion are strongest. There was generally a lack of experience of repulsion as distinct from attraction. Barrow (1987) stresses the importance of work with two magnets (in the context of distinguishing between a magnet and magnetic material which is not magnet used Gagliari (1981) stresses the importance of repulsion as the only test for a magnet to distinguish it from magnetic material).

Barrows study found that pupils' awareness of the uses of magnets had not been extended by teaching. Barrow raises the possibility that teaching about magnets might dissociate pupils from their everyday awareness of magnetism. With this in mind, approaches which draw in everyday experience and focus upon the use of magnets would be advisable.

A study of pupils between the ages of 3 and 9 by Selman *et. al* (1982) found two levels of conception of magnetism the first level appeared to be only linking events. At a more sophisticated level the notion of an unseen force began to emerge and pupils talked of a magnet working by pulling on things.

Finley (1986) studied the effect of a television programme about magnets on the ideas of twenty-four pupils. Pupils, prior to the programme, referred to magnets sticking to objects and they recognized specific examples of things affected, such as pins or paper clips. They also thought of big magnets as stronger than small ones. After the programme; magnets were thought of in terms of picking up rather than sticking, and there was awareness of action at a distance. Pupils identified a generic group of materials affected by magnets,

although they took this to be all metals rather than certain metals. The effect of the program's presenting a small strong magnet has simply to reverse pupils' prior ideas such that they thus thought of all small magnets being stronger than all big ones. In general pupils appeared to have embraced some of the ideas of magnetism without adopting the language and the use of words attract, repel or magnetize.

### **Electromagnetism.**

Pupils in barrows study did not generally recognize the magnetic effect of an electric current; only 10 per cent did so. Selmen *et. al* found some pupils in the 3-9 age groups focusing on the wire as the active agent whilst others referred to electricity as the explanation of electromagnetism. In a sample on ninety four 13 year olds, Anderson found sixty four who thought that a coil of wire had to be uninsulated in order to create an electromagnet.

### **Light and optics.**

#### ***The nature and representation of light.***

Ideas about the nature of light are often taken for granted in school science and the only definition given is usually that it is a form of energy. Watts (1984) suggested that young people are therefore in the position of having to construct their own understanding of what light is whilst exploring its properties.

Guesne (1985) concludes that most 10 and 11 year old children conceive of light as a source (such as an electric bulb), an effect (such as a patch of light) or a state (such as brightness). She found that children of this age did not recognize light as physical entity existing in space between the source and the effect that it produced. She also found that at the ages of 13 and 14 many studies recognized light as an entity, the majority using this notion to explain shadows but only where the light was intense enough to produce perceptible effects at some point in its path.

Ramadas and Driver (1989) report on the findings of a study involving 456 15-year-olds in which various ideas about light were considered. When questioned about light rays many children thought of them as long; thin, flashing, unlike ordinary light. Pupils sometimes associated them with science fiction contexts. The fact that the path light takes is not itself directly visible presented special difficulties for children, especially in representing the presence of light in various situations. Darkness appeared to be as important a part of students' conceptions as light and in their diagrams. It was not uncommon, in certain contexts, for students to shade in the darkness on white paper instead of shading in the light.

Investigating children understanding of source of light Osborne *et. al* (1990) found that children between the ages of 7 and 11 showed knowledge of a wide range of source but that they talked about primary sources nearly four times as often as they mentioned secondary sources of light. These researches found no evidence to suggest that the children's ideas about sources developed with age. This study also considered the representations used by children to show light and it found that nearly all children's drawings showed the light around sources represented by short lines. The use of extensive numbers of lines linking source and object was very limited. The representations used by older children become more varied and context dependent. Very few children offered no representation of light, although for many lower juniors it was limited to simple lines surrounding the source.

Andersson and Karrqvist (1981) made observations on colloquial speech and they suggest that the everyday concept of light is psychological rather than physical in nature, citing phrases such as 'the light is bad' or it is light. The other meaning of light which they noted in the English language has a source of light such as an electric bulb.

Watts and Gilbert (1985) suggest seven frameworks which encompass the bulk of youngster's responses about light

- Ambient light where a distinction is drawn between direct light and normal daylight (on a scale which runs from very bright to dark, daylight would be somewhere near the midpoint and shadows are thought to occur only in bright light).
- Composite light in which responses describe the composition of light (although some children treat light as a single entity, many discuss its parts or bits)
- De-coupled light in which the responses describe light as being completely separate from seeing (situations are thought to require light in order that things are lit up but there is no suggestions that light is then reflected to the eyes: rather, eyes simply observe a well-lit scene).
- Illuminative light in which responses describe light as intentionally designed to allow us to see and which emphasis the general human purpose of light.
- Modal light in which many different kinds of light, derived from different circumstances and giving different effects are identified.
- Obvious light in which light is thought to be property only of large conspicuous luminous bodies.
- Projected light in which responses treat light as a substance that is projected, in some instances transporting colours (light might be described as a directed beam which can be stopped or slowed down by obstacles)

The science view of light does not appear to be common among pupils. In a multiple-choice question about how a lamp brightens a room Anderson and Smith (1983) found that more than 75 percent of the sample of 27 did not choose the scientifically correct answer but preferred a response that specified no mechanism at all by which a lamp brightened a room

When children have notion of light as an entity they do not necessarily think of light travelling – a point made by Guesen (1985), La Rosa *et. al* suggest

that students who talked of light going from point A to point B might have thought of it as like a wire or a rod going from A to B.

Watts (1984) describes a boy who talked about rays of light as strands of a rope making up a beam of light and also about light in different modes such as natural or electric.

Stead and Osborne (1980) used different contexts (such as candle, a lamp, a TV and a mirror) to test for the idea of light existing in space. They found that most students did not think of light traveling out very far from the source, particularly in day time. Pupils thought of light as travelling further at night. Fetherstonhaugh and Treagust (1990) found that around 40 per cent of the forty seven 13 to 15 year olds in their study thought that light travels different distance depending up on whether it is night or day. About 20 per cent believed that light does not travel at all during the day. A smaller proportion thought that light did not travel at night.

Feher and Rice (1985), from their work on children's ideas about shadows, conclude that many younger children think of a shadow as the presence of something that light allows us to see, rather than as the absence of light. The shadow was thought of as existing on its own hiding in the object, until the light pushes the shadow away from the object on the wall or ground. These researchers suggest that children tend to expect the shadow of an object to be the same shape as the object. Pupil's explanations of their prediction often reoffered to the shadow as a reflection or as a dark reflection on the screen.

Gusen (1985) found that 10 and 11 year old children perceived the light source as being responsible for shadows but noticed only the reproduction of the object form. The majority of 13 and 14 year olds interpreted shadows in terms of an obstacle blocking the passage of light and they used the notion of light entity in space. Tiberghien *et. al* (1980) report that ninety percent of their sample of ninety four 10 and 11 year olds correctly located where their own shadow would

fall when the sun was in front or behind them. The same group of children found more difficulty in anticipating where the shadow of a tree would fall, with 60 percent offering the correct idea of the relative positions of the source, the object and the objects shadow. Pupils did not offer an explanation in terms of straight path of light.

When children were asked why red light is seen to come from a red projector slide, Zyberstajn and Watts (1982) found that only 2 per cent of the sample of 150 13 year olds gave an answer in terms of transmission of some frequency of light, despite having recently been taught about color. About half thought that the white light from the projector had been changed in some way, with a third of this group suggesting a dyeing mechanism. Another 13 per cent of the total offered models in which the white light projected the color of the filter forward in a kind of knock on effect.

Anderson and smith found that 72 percent of their sample did not think that white light was a mixture of colors of light. Of those who did not hold the idea, only 20 percent also know all the colors involved in the mixture. Sixty one per cent of the children thought that color was an innate ability of an object and that light helped our eyes to see the object. They thought that our eyes see the color of the object rather than the color of the reflected light.

Watts (1985) conducted a study on student conceptions of light. A detailed description is given of the views of a high school student on the nature of light. Saxena (1991) conducted a study on understanding of the properties of light by students in India. This article reports the results from a multiple-choice test that was administered to both secondary school and undergraduate students in India.

Goldberg and McDermott (1981) conducted a study on difficulties in understanding image formation by a plan mirror. During interviews university students were shown an object in front of a mirror and asked what an observer at

various locations would see. Many students could not make correct predictions either before or after instruction.

Goldberg and *et. al* (1981) conducted an investigation of student understanding of the real image formed by a converging lens or concave mirror. Even after instruction, many students could not apply the formalism of geometrical optics to predict or account for the image formed by a converging lens or concave mirror.

Ambrose and Shaffer (1999) conducted an investigation of student understanding of single-slit diffraction and double slit interferences. This article identifies specific difficulties that many students have in selecting and applying an appropriate model to account for the pattern produced on a screen when light is incident on one or two narrow slits. It is also found that students at introductory and more advanced levels have seriously mistaken beliefs about photons and the wave model of matter.

### **Sound.**

Many children's explanations of how sounds are produced are in terms of the physical properties of the material producing the sound. Children suggest that the sound is produced because the object is made of plastic or of rubber, or because it is thick, thin, taut or hard. This idea is noted both by Watt and Russell (1990) and by Asoko *et. al* (1991). The latter note that younger children very often link the production of sounds with their own actions, or consider the sound to be part of the instrument, 'released by human actions'.

Watt and Russell found that pupils often commented upon the action used to generate the sound and attempted to suggest a mechanism for sound production. The proportion (of a groups of fifty-seven) suggesting a mechanism for sound production from a drum increased with age, from 13 per cent of infants to 95 per cent of upper juniors. The suggested location of sound generation also changed with age: younger children suggested that sound is generated inside the

drum and older children that it is generated on the surface; although some explanations involved both. Mechanisms of sound production offered by the children were context-specific, those proposed for a rubber band being very different from those proposed for the drum. However, there have three main groups of explanations.

- Those which involved the physical attributes of the object (for example, the tautness of a drum)
- Those referring to the force needed to produce the sound (for example, the human action of beating the drum)
- Those which involved vibrations

Asoko *et. al* Working with 260 pupils between the ages of 4 and 16, explored ideas about sound production in four contexts: a guitar string being plucked; a tag hooter horn being sounded by squeezing the bulb; stones being clashed together; and a cymbal being struck. Although they found that reference to movement or vibration of the sound source became more common with increasing age, this was context specific to objects which could very obviously be seen to vibrate, such as the guitar string and the cymbal. No pupils used ideas about vibrations consistently, in all contexts.

With reference to the guitar, there was an increase throughout the infant and junior years of responses which referred to the vibration of the source. At the same time there was a decrease in other ideas, particularly those relating only personal action and properties of the source, such as tautness. Approximately 80 per cent of the responses of secondary children referred to vibration of the guitar string. However over the whole age range very few children described the transfer of the vibrations of the string to the surrounding air.

In thinking about the cymbal, almost 40 per cent of reception class children associated the sound with vibration, and the proportion was greater among older children as personal action references decreased. Again there was

very little mention, by children of any age, of the vibration being transferred to the air.

In the context of the hooter horn, references to vibrations were far fewer. The younger children explained the hooter horn in terms of personal action but this notion fell away sharply with age as more references were made to the involvement of air to movement. The number of replies focusing on the involvement of air remained high, with approximately 40 percent of the secondary aged sample referring to it. There were very few references to the vibration of the source and even fewer to the vibration being passed to the air.

When the students considered how the stones produced sound, the vast majority of answers at all ages referred to personal action and these responses were often complimented by references to the proper ties of the stones. There were virtually no explanations based on the involvement of air or vibrations.

Asoko *et. al* suggest that, because children do not have a generalized theory of sound production transferable across contexts.

Teachers should plan to give children experience of sound production in less obvious contexts as well as in contexts where the vibrations are clearer. It may be useful to allow the children to experiment with applying vibration ideas developed in obvious contexts to less obvious contexts with a view to developing a generalized theory.

They also propose that, because the role of the ear does not appear to be problematic for most children, this may be useful contexts for developing ideas about vibrations in air. When explaining how covering a sound affects its volume many children used ideas about gaps or stopping the sound and these ideas may lead to the scientific view of sounds as vibrations travelling through air and other materials.

### **Sound transmission.**

Watt and Russell (1990) found that the idea of sound traveling was not one which children readily expressed. When they did so, they tended to think that the sound needs an unobstructed pathway in order to travel. This idea seems to draw upon everyday experience of moving among furniture, of umbrellas stopping the rain or of building a dam across a stream, where movement would be impeded by anything in the path. Watt and Russell suggest that children may envisage sound as an invisible object with dimensions, which would need room in order to move. The idea that air is needed as a medium for sound transmission was rarely mentioned, but when it was Watt and Russell (1990) concluded that children's notion of air had a bearing on their understanding of sound travel for example, those children who envisaged air as empty space would be thinking of sound transmission in air as sound traveling through an empty space. Likewise Asoko *et. al* found that pupils rarely suggested a mechanism for sound travel at any age. Moreover, it was difficult to interpret children's explanations when certain expressions, such as sound 'goes' could have had various meanings. When they were asked how the ticking of a clock is heard, children up to the age of 14 focused their answers either on the mechanism of the clock or on the personal action of the child listening. The role of air was mentioned only a small number of children. Only among 16 year-olds has the notion of sound travel in air common: it was referred to by 70 per cent of this group.

Difficulties in thinking about sound traveling are not restricted to younger children. In a study of tertiary students, who were shortly to go on to teach secondary school physics, Linder and Erickson (1989) observed four conceptualizations of sound.

- As an entity that was carried by individual molecule to another through a medium.
- As an entity that was transferred from one molecule to another through the medium.

- As a substance which traveled, usually in the form of flowing air
- As a substance in the form of some traveling pattern

Linder and Erickson describe the first two perspectives as ‘microscopic’ given that the students explained sound in terms of molecules and tended to portray sound as a thing’ they describe the other two perspectives as macroscopic; since students explained sound in terms of the bulk properties of the medium.

### **Heat and temperature.**

Children’s ideas about heat have been the subject of a lot of research and studies have taken place in many countries, certain patterns emerge and it is clear that children have difficulty in understanding this area of science. Harris (1981) as reported by Hewson and Hamlyn (1984) suggests that the source of this confusion centers on the use of words like ‘heat’, ‘heat flow’ and ‘heat capacity’. Harris (1981) referring to students tendency to think of heat as a ‘substance’ which flows from place to place, claims that ‘many’ ‘students’ conceptions of heat today are, on the whole, not very different from those of Lavoisier (1789), that is, they think ‘calorically’. Indeed, many researchers have found that children think of heat as a substance, and Hewson and Hamlyn (1984) have drawn attention to language and cultural influences.

Erickson reported that children think of heat as a type of subtle substance, like air, that is capable of flowing into and out of objects. Other studies have observed a similar notion and that the substance is often thought to flow or have fluid characteristics. Erickson noted that both cold and heat are often associated with air.

Engel Clough and Driver (1985) report that pupils up to the age of 16 think of cold as an entity which like heat, has the properties of a material substance. It appears that children do not necessarily think of hot and cold as part of the same continuum. Rather they perceive them as two different phenomena, with cold often being thought of as the opposite of heat.

Watts and Gilbert (1985) found seven alternative frameworks for thinking about heat which have commonly used by a group of 14 to 17 years olds.

- Conspicuous heat, in which heat is only associated with very hot bodies and large amounts of heat;
- Dynamic heat in which heat is associated with movement;
- Motile heat, in which heat is seen as something which spreads out from one place to another and as more insidious and fluid-like than direct (conspicuous) heat;
- Normal heat, which is taken as body temperature and humans are seen as the standard for measuring heat
- Product heat, which is taken to be manufactured, deliberately contrived heat as distinct from natural heat;
- Standard heat, in which any temperature above 'freezing' represents heat and in which cold is the opposite of heat and applies to any temperature below freezing.
- Regional heat, which assumes a static model of heat occupying a particular area, and cooling, is seen as a reduction of heat intensity.

Erickson reports that distinguishing between the concepts of heat and temperature was one of the most difficult tasks for children. They tend to view temperature as the mixture of heat and cold inside an object, or simply as a measure of the amount of heat possessed by that object, with no distinction between the intensity of heat and the amount of heat possessed. Many children think that the temperature of a body is related to its size, volume or the amount of stuff present. Children also think of temperature as a property of the material, their everyday experience of touching objects supporting a notion that some substances are naturally warmer or colder than others. When considering pupils ideas of the differences between heat and temperature, Tiberghien (1983) reports three categories of response.

- The idea that heat is hot, but temperature can be cold or hot: temperature you can have something freezing, whereas heat – you tend to think of something being hot. Heat.... It's the warm end of the scale (this view was more common among 10 to 12 year olds).
- The idea that there is no difference between heat and temperature: temperature is heat (this type of thinking was found in pupils from age 10-16).
- The idea that temperature is a means of measuring heat: Temperature – you can measure heat with, but heat is not – you can feel heat.

Tiberghien notes that children do not recognize temperature as a physical parameter that can describe the condition of a material for them other criteria are more pertinent for describing materials.

There have been several studies of childrens ideas about the resultant temperature when volumes of water at different temperatures are mixed. When a quantity of cold water is mixed with an equal quantity of hot water children often say that the mixture will be 'warm'. However, if the initial temperatures of the water are given there are fewer correct answers.

Driver and Russell (1982) studying 324 Malaysian and English pupils found that over 50 per cent of 8 to 9 year olds and 80 per cent of 13 to 14 year olds gave correct qualitative judgments, but less than 25 per cent of 13 to 14 year olds predicted an average temperature when numerical values were introduced. They tended to add or substrate the two initial temperatures to find the final one. This pattern was also found by Stavy and Barkovitz in their study of seventy seven Israeli, 9 to 10 year olds.

Strauss and Stavy (1982) report that, when considering the final temperature of a mixture of two beakers of Cold water. Children aged 4 to 6 often judged the temperature to be the same. However, older children, and 5 to 8, often said that the water would be twice as cold because, there was twice as

much water. Older children aged, upto 12 again judged the water to have the same temperature as the separate beakers. To explain this, Strauss and Stavy suggest that the youngest children do not consider the amount of water when making their judgment, whereas older children do attend to the amount and judge the temperature as if it were an extensive physical quantity. The oldest children are able to differentiate between intensive and extensive quantities and make judgments accordingly, understating that the temperature remains unchanged despite changes in the amount of water. Strauss and Stavy also found that children tended to make more correct predictions of temperature when equal amounts of hot and cold water mixed, than when two equal amounts of cold water were mixed.

### **Properties of matter, fluid mechanics and thermal physics.**

Misconceptions frequently occur in these areas are a) Heat, Temperature and Thermodynamics, b) Pressure, density and Structure of matter

#### ***Heat, temperature and thermodynamics.***

Warren (1972) conducted a study on teaching of the concept of heat. This paper discusses the inability of first year university students to separate the concepts of heat, internal energy and temperature.

Johnston and Webb (1977) conducted a study on misconception in school thermodynamics. A thermodynamic approach test was administered to 98 middle and high school students in Scotland. Eight prevalent “misconceptions” were identified. Several of these pertain to chemical reactions.

Erickson (1979) conducted a study on childrens conceptions of heat and temperature. It was observed in the study that many students aged 11-16 believe that heat and cold are substances and that temperature is a measure of their amount few students were able to distinguish between heat and temperature. Alwan, A.A. (2010). Conducted a study students of different category and the

findings revealed that most of the students held alternative conceptions of heat and temperature.

***Pressure, density and structure of matter***

**Pressure.**

Research into ideas about pressure has focused up on fluid pressures and particularly air pressure. Sere (1982) working with eleven French 11 to 13 years old, pupils found pupils thinking that only wind, and not still air has pressure. Working with eighty four 12-14 and 16 year old, Engel Clough and Driver (1985) found high proportion thinking that pressure increases with depth. However pupils were less inclined to think in terms of pressure acting in all directions in air or water, they were inclined to think of a greater pressure downwards. This study found frequently references to air or a vacuum sucking in pupil's explanations changes experienced with straws and syringes. Atmospheric pressure pushing was mentioned but few pupils explained in terms of balancing pressure.

Studying French 11 to 13 year olds and their ideas about air pressure differences and consequently movement of air, Sere found 85 per cent accurately describing the extent to which air is squashed in a ball before and after blowing it up. However only 63 percent of the pupils accurately compared air pressure inside the ball with the air outside. Generally pupils did not readily make pressure comparisons. An important finding from Seres (1982) study is that pupils tend to associate pressure in gases with moving air assuming pressure acting in the direction of motion. There were fewer tendencies to associate pressure with static gases.

Mackinnon and Geol (1971) conducted a study on Earth Science, density. He describes how student difficulties with ratio reasoning can lead to difficulties with the concept of density, even among university students.

De Berg (1995) conducted a study on student understanding of the volume, mass and pressure of air within a sealed syringe in different states of compression. He studied the responses of high school students in England. Only about one-third of students demonstrated a qualitative understanding of these concepts.

Anderson (1989) conducted a study on pupils conceptions of matter and its transformation. This paper reviews some of the research literature on the ideas of high school students about matter, including chemical reactions, phase transitions, conservations of matter, and the nature of atoms and molecules.

### **Energy.**

Across the field of research studies on pupil's ideas about energy, several recurring conceptualizations of energy have emerged. Energy is seen as:

- Associated only with animate objects
- A causal agent stored in certain objects
- Linked with force and movement
- Fuel
- A fluid, an ingredient or a product

### ***Energy and living things.***

The idea that energy is associated with living things and particularly with human beings is reported from several studies. Watts and Gibert (1985) describe several frameworks observed among children one of these involves 'human centered energy' in which energy is associated mainly with human beings or with objects which were treated as if they had human characteristics. Such anthropomorphic views were found to be held by pupils of all ages including 'A' level students.

Solomon (1983) examined children's thinking about energy by asking them to write three or four sentences showing how they would use the world

'energy'. Human activities, health, food and fuels all figured prominently in pupil's responses, which showed a movement with age away from the idea of energy associated only with living activities and also a significantly greater interest in living associations on the part of girls than among boys.

Solomon outlined four themes into which responses fell. Two of those were:

- Vitalism, in which energy is thought to be needed for life (as in when we run out of energy we need medicines and vitamins and exercise is good for you, it builds up your energy)
- Activity, in which we are thought to need energy to more (as in 'when we run out of energy we need food and rest' and exercises use up energy, than you become tired)

### **Energy, movement and force.**

Many children appear to link energy with movement and force. Stead (1980) found that those children who associated energy with inanimate objects often suggested movement or the lack of it, as determining whether energy was present or not. Absence of activity was reported by Bliss and Ogborn (1985) as an explanation given for energy not being attributed to a situation. Watts and Gilbert (1985) found an obvious activity framework among their subjects, in which energy was associated with over displays of movement. Often the outward display itself was thought of as the energy: energy was thought of as doing.

Duit (1981) notes a close association between energy and force in children's response. Watt and Gilbert (1983) also found some students using the word 'force' and 'energy' Synonymously and some treating the two concepts as distinct but interconnected.

Ault *et. al* (1988) found an undifferentiated view of energy, work, force and power amongst their students, and Barbetta *et. al* (1984) suggest that

confusion in the use of the words 'force', 'energy' and 'work' is not only terminological but conceptual the latter group found that two-thirds of the pupils who had not been exposed to the concept of energy in class thought that it was something necessary for movement and/ or that it was a type of force. The remaining pupils offered no ideas. The majority of pupils who had been introduced to the concept of energy answered by giving text book definitions or by question forms of energy.

Brook and Driver (1984) also found that pupil's notions of energy movement and force were strongly associated. Almost one in five of their pupils focused on the amount of force which a ball-bearing had at different points on a track and some used the words force in a way similar to that in which a scientist would use 'kinetic energy'. About one in ten children thought that a truck would have energy only when moving, or would have most energy when moving. These researchers suggest that students tend to focus on directly observable features of phenomena rather than on abstract ideas (such as energy) which are often used by scientists.

Confusion between energy, force friction, work and gravity was identified by Stead (1980) who also noted that potential energy was confused with the potential to have energy.

Several researchers have found pupils holding ideas of energy as a fuel, with global perspectives and ideas about limited resources. One of the themes which Solomon (1983) identified in children's responses relates to shortage of energy in the future and the need for new sources of energy to meet the world's needs. Duit (1981) found that German students closely linked energy with fuels and electricity, although this was not the case for students from the Philippines.

Stead found that for pupils 'energy' was synonymous with fuel and that phrases like energy crisis and conserve energy meant fuel crisis and conserve fuel. Children had the notion that fuel is energy rather than that fuel 'contains' or is a source of energy.

Watts and Gilbert describe the fundamental model of energy in which energy is a very general kind of fuel. Energy is associated mainly with technical applications. It is not seen as essential to all processes but just those which make life comfortable. A similar notion of energy as a fuel was also noted by Ault *et. al.*

### **Gravity.**

Several studies investigating children's ideas about the earth gravity. Selman *et. al* (1982) has classified pupils thinking about unseen forces in general, identifying broad phases in which they perceive unilateral, then multiple and balanced forces. Others have studied developing ideas about gravity in particular. A detailed study, by Stead and Osborne (1980) of New Zealand pupils aged 11 to 17 revealed ideas of gravity pushing, pulling or 'holding' appeared to be the most common perception of gravity and this was bound up with ideas of gravity being connected with air pressing down and with an atmospheric shield which prevents things floating away. The notion that there must be air for gravity to act appears to be widespread. It has also been found among Italian middle school pupils by Ruggiero *et. al* (1985). The idea that gravity is in some way related to air has implications, of course, for the way pupils think about gravity acting in space, on the planets and on the moon. Relating gravity to air appears to offer an explanation of gravity which is less outside objects rather than in terms of a property of all objects. Stead and Osborne found only one pupil in a sample of 42 who had the idea that all objects exert a gravitational force.

A considerable amount of work has been directed towards pupils' ideas about the way gravity changes with height above the earth's surface. Significant numbers appear to hold the physicists view that the force of gravity decreases with height above earth surface. Stead and Osborne (1980) found one – third of a sample of 257- 14 year olds thinking this way and Ruggiero *et. al* (1985) also found this idea among 12 and 13 year olds. However, it appears that pupils who hold this view tend to expect a far bigger decrease in the force of gravity with increasing height than is actually the case.

Stead and Osborne (1980) also found one-third of their 14 year old sample holding the view that gravity increase with height above the earth. This idea was also present among pupils studied by Ruggiero *et. al* (1985). Pupils holding this the 'higher the stronger' gravity view assume this applies until things get outside the earths atmosphere. Watts (1982) found that pupils with 12 – 17 age range thought that gravity depends upon height, but they appeared to confuse gravity with potential energy in assuming a higher force of gravity at greater height.

### **Lunar phenomena.**

Childrens (Barnett & Morran, 2002; Dove, 2002; Sharp 1998; Taylor & Jones, 2003; Trumper, 2001) Science and non-science university students (Zeilik and *et. al*, 1998), preservice teachers (Suzuki, 2003; Trumper, 2003) and in-service Teachers (Parker & Hey Wood, 1998; Summers & Mant, 1995) conceptions of the moon and some lunar phenomena have been a central focus for various studies from different countries. Some of these studies were conducted after the instruction and the results were compared with those gathered before instruction.

Dove (2002) for example, analyzed the response to nine questions about astronomical events provided by 98 girls attending a secondary school in the UK after they were instructed for a certain period. She found that the reason why the moon always presented the same face to the earth was less well understood and estimations of the time in earth days from sunrise to sunrise on the moon varied.

Taylor & *et. al.*, (2003) worked with elementary students in New Zealand and implemented a 16 day period of teaching intervention. They found that while 53% of the students determined the moon as the main cause of tides on earth in the pre test, the rate was increased to 100% after 11 intervention lessons. Moreover, whereas 9% of the student in the pretest accepted the sun's affect on tides, the number was 63% in post test. They reported that before the intervention almost all student know that the moon could be seen in the day time sky, but none of the students selected scientists responses for the cause of moon phases.

Suzuki (2003) found that pre-service teachers had some knowledge of the moon; however, they assumed that the moon could only be seen at night.

Trumper (2003) conducted a study on Israel student teachers and presented the following result; a considerable number of students misunderstood the role of earth and sun in the cause of moon phases. A great proportion of students reasons for seeing the same side of the moon has that the moon did not rotate on its axis, and some of the students claimed that the moon only revolved around the earth and not around the sun.

A considerable amount of research has been conducted to determine both childrens and adult conceptions of moon phases only (Collison & Wright, 1993; Dai & Capice, 1990; Rider, 2002; Stably & Sphepardson, 1990; Taylor, 1996) “there is evidence that people with vertical levels of schooling and training from elementary school through in-service Teachers do-not understood the cause of moon phases” (Trundle & *et. al*, 2002) and some of them still hold misconceptions even after they were provided a scientifically correct explanation” (Hermann & Lewis, 2003; Callison and Wright, 1993). For example determine pre-service elementary teachers scientifically inaccurate views about moon phases before the instruction and concluded that some of them kept inaccurate views after the instruction. Analysis of the research indicates that the most common misconception of the cause of moon phases hold by students is “Earth shadow falling on the moon”.

Review of the literature shows that, although from different countries, there are commonalities in people understanding of the moon and some lunar phenomena. These commonalities are follows, the moon does not rotate on its axis, the moon is the only cause of tide on earth, the moon is seen only at night, and the moon does not revolve around the sun.

Miller (2010) Quantitative estimated of the nature of the misconception among United State university students by asking them, in an open-ended response

format, to make estimates of the distances from the Earth to the Moon, The data showed that while there is great variation, a general pattern emerged that US undergraduate participants overestimated the distance from the Earth to the Moon, moderately underestimated the distance from the Earth to the Sun, and dramatically underestimated the distances to the nearer star and to the nearest galaxy.

Rosemary A, M.(2014)in a science misconception workshop focused on demonstrating instructional strategies that bring about understandings through successful verbal and written explanation of science concepts the use of academic language and modeling concepts through interactive role-play. The workshop replicated instructional intervention strategies implemented by teachers who participated with their students as a part of the authors' research studies with middle school students it is revealed that sixty percent of students exhibited misconception in moons phases.

### **Effectiveness of Conceptual Change Strategies**

Recent researches have demonstrated how different individual learners can be and how teaching methodology should vary accordingly. (Linder, 1993; Novak, 1998; ScotAsoko & Driver, 1991). The methods and strategies that can be employed to dispel misconceptions include verbalization of misunderstandings (Marioni, 1989; Scot, Asoko & Driver, 1991),metacognitive strategies (Hammer, 1989; Gorden, 1996), concept mapping ((Fraser & Edward, 1987), anchoring conceptions(Clement *et. al*, 1987) analogical reasoning (Clement, 1987; Shultz; and Murrey, 1987), computer simulations (Dykstra, Boyle and Monarch, 1992) among others.

One of the most common teaching strategies for conceptual change is verbalization of the students understanding. (Marconi, 1989; Scot, Asoko & Driver, 1991). If student can group their difficulties verbally; they are a step closer to overcoming them.

Metacognitive approach can definitely help students understand where they are having difficulty with their understanding of physics. Methods for

identification of misconceptions have been proposed by Tobias (1987) and others. Most of these techniques require the student to keep journal style record of their learning and problems they have encountered in learning. (Hammer, 1989; Gorden, 1996). However, Some of the approaches are more explicit in their use of metacognition as they require the student to consciously think about how they learn best.

The concept map techniques have been a popular topic in literature for years. Concept maps illustrate the relationships between ideas in a knowledge domain as lines graphically linking key words. Through concept mapping, students learn to visualize a group of concepts and their interrelationships within a domain (Fraser & Edward, 1987).

Many preconceptions are detrimental to learning; there may be other preconceptions that are largely in agreement with accepted physical theory. These are known as anchoring conceptions or more briefly as anchors (Clement *et. al*, 1987). Studies have shown that significant gains can result from bridging from an anchor without the benefit of empirical demonstration (Brown, 1987). A teacher can help a student more conceptually from anchor to target by using a bridging analogy (Clement, 1987; Schulz & Murray, 1987).

Analogical reasoning as a tool for helping students overcome misconceptions is described by different researcher as bridging analogies or chains of analogies (Clement, 1987; Shultz; and Murrey, 1987). Computer based tutors have been programmed to use bridging analogies or conceptual chain to tutor students in such topic as forces in static (Schutz, Clement & Brown, 1987). The software chooses how to present information to the user dependent on their responses.

Various technologies have been shown useful in confronting and remediating misconceptions. Computer simulations run within a constructivist classroom will bring the students to question their own conceptions (Dykstra, Boyle and Monarch, 1992). Commercially available computer simulations help students avoid forming misconceptions (Coleman, 1997) and can be used to

challenge students conceptions through the presentation of discrepant events (Tao & Gunstone 1999).

There is no common instructional strategy for all misconcepts. It will vary according to the nature of concept. Eventhough many studies are done abroad about the identification and remediation of misconcepts, it is necessary to do a study here by locally because misconceptions can arise by locally prevailing beliefs, metaphors, instructional environment etc (Ivovi & Oludotum, 1987).

So the proposed study is an attempt to identify the misconcepts in physics among VIII standard students in Kerala and to test the effectiveness of an instructional programme developed out of an eclectic array of strategies tried and found effective else where by some isolated successful teachers and researchers. This will help the normal physics teacher by prescribing him a set of proven strategies appropriate for remediation of the most prevalent misconceptions in Kerala context.

### **Conclusion**

From the literature research, it appears that misconceptions are much more complex and prevalent than simple misunderstandings or receiving incomplete information. There are multiple methods for arriving at misconceptions. They can occur as result of misunderstood vocabulary or they can occur because of combining several ideas into one. Some are caused by deeply held beliefs, while others are caused because the recipient was overwhelmed with information causing a shutdown of all processing. Misconceptions can also occur from not knowing where or how to look to find the correct answer. The next thing that calls for investigation is how teachers can help students to confront and overcome their misconceptions.

Majority of the studies done on the area of misconception were on above high school level. All of them were done abroad. There is lack of sufficient studies regarding the misconception among high school students especially in Kerala. Majority of the studies confined to a few areas and rest to be revealed and conquered by further studies.

## METHODOLOGY

---

↪ **PHASE 1: SURVEY OF MISCONCEPTIONS IN MAJOR AREAS OF PHYSICS AMONG STANDARD VIII STUDENTS**

- VARIABLES IN THE SURVEY PHASE
- DESIGN OF STUDY IN PHASE 1
- TOOLS USED
- SAMPLE FOR THE SURVEY PHASE
- DATA COLLECTION PROCEDURE DURING SURVEY PHASE
- IDENTIFICATION AND EXTENT OF MISCONCEPTIONS IN PHYSICS

↪ **PHASE 2: INTERVENTION FOR REMEDYING THE MISCONCEPTIONS IN PHYSICS**

- VARIABLES IN THE EXPERIMENTAL PHASE
  - EXPERIMENTAL DESIGN
  - TOOLS USED IN THE EXPERIMENTAL PHASE
  - EXPERIMENTAL SAMPLE
  - STATISTICAL TECHNIQUES USED FOR ANALYSIS
-

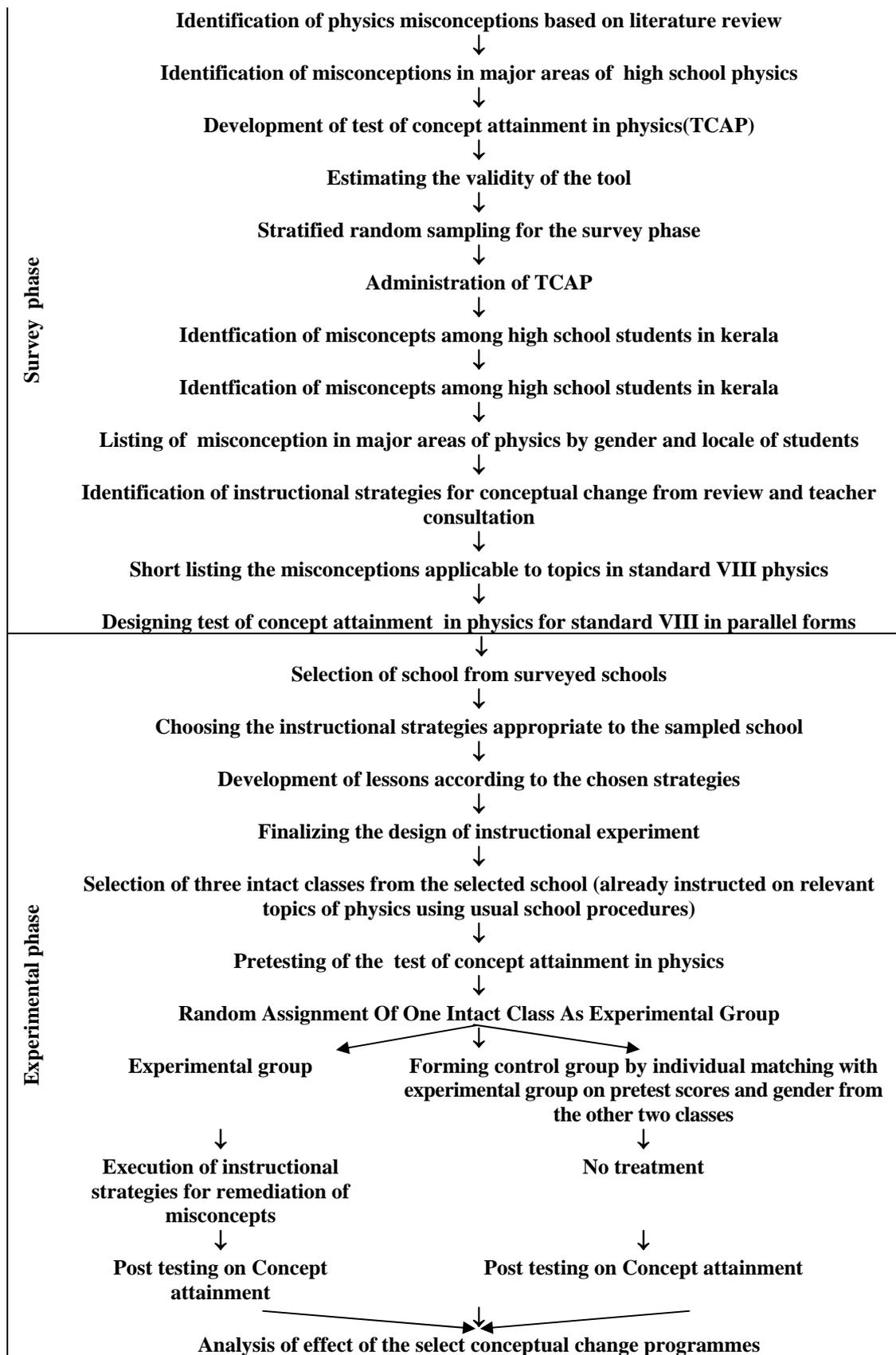

Figure 1. Outline of procedure

This chapter describes the design of the study, variables, samples selected for the study, tools used, lesson plans for remediation of misconceptions in physics, and the statistical techniques used for the analysis of data. Present study as indicated in the title is identification of misconceptions in physics and testing of effectiveness of certain instructional programmes on remediation of the misconceptions among VIII standard students in Kerala. This involves identifying frequently occurring misconceptions in physics among secondary school students, and verifying the effectiveness of selected instructional strategies in correcting the identified misconceptions among standard VIII students of Kerala. With these broad objectives, the following specific objectives were set for this study.

1. To find out the percentage of error committed in each of the selected concepts in physics viz., (1) Matter, (2) Solar System, (3) Density, (4) Velocity, (5) Mass, (6) Gravity, (7) Work, (8) Energy, (9) Light, (10) Sound, (11) Electricity, (12) Magnetism, (13) Pressure and (14) Force by the secondary school students in the total sample.
2. To find out the percentage of error committed in each of the minor concepts involved in selected concepts in physics viz., (1) Matter, (2) Solar System, (3) Density, (4) Velocity, (5) Mass, (6) Gravity, (7) Work, (8) Energy, (9) Light, (10) Sound, (11) Electricity, (12) Magnetism, (13) Pressure and (14) Force by the secondary school students.
3. To identify the major concepts in physics and the minor concepts involved with each of them in which there exists significant difference in the percentage of error between boys and girls among VIII standard students of Kerala.
4. To identify the major concepts in physics and the minor concepts involved with each of them in which there exists significant difference in the percentage of error between rural and urban of VIII standard students of Kerala.

5. To find out the effectiveness of a range of selected experimental instructional strategies in remediation of the identified misconceptions in physics among VIII standard students of Kerala.

The present study is completed in two phases. For obtaining a summary view of the methodology at a glance, the outline of the total procedure is given above in Figure 1.

Phase 1 of the study is for the identification of misconceptions in various concepts in physics that students have learnt from their primary classes to high schools and for verifying whether the extent of misconception differs by gender of students and locale of school. This phase is to help identify major conceptual areas which are comparatively more prior to misconceptions. Phase 2 is for testing the effectiveness of an intervention for remedying the misconceptions identified during the survey phase, albeit limited to the selected topics in standard VIII physics and one randomly selected school from among the schools that participated in the survey phase. This phase of the study employed a quasi – experimental design. Hence, methodology of this study can be described as a mixed approach, a survey phase followed by an experimental phase.

### **Phase 1: Survey of Misconceptions in Major Areas of Physics among Standard VIII Students**

The survey was designed to find out the extent of misconceptions in selected concepts of high school physics among standard VIII students. Investigator selected 14 major concept areas from the Physics textbook and also on the basis of reviewed literature where the rate of incidence of misconceptions in selected areas in secondary school physics, namely, Matter, Solar System, Density, Pressure, Velocity, Mass, Force, Gravity, Work, Energy, Light, Sound, Magnetism and Electricity were explored for misconceptions in their minor concepts. This was also done, based on the reviewed literature where the incidence of misconception is comparatively

high. The fourteen concept areas in physics and their minor concepts involved were chosen on the consultation with teachers of secondary school physics. The concern of survey phase is to explore the rate of incidence of misconception in selected areas making the survey phase as a background on which the investigator planned the remediation programme.

### **Variables in the Survey Phase**

Survey phase of the study explored the misconceptions in physics among secondary school students, in the total sample and subsamples based on gender and locale of students.

#### **Attribute variables.**

Survey phase has the following attribute variables, viz.,

- 1) Gender
- 2) Locale of students

#### **Criterion variables.**

The criterion variables in the survey phase are misconceptions in physics. This variable is explored in terms of misconceptions in fourteen major conceptual areas of physics selected from high school physics curriculum they are viz.,

1. Matter
2. Solar system
3. Density
4. Pressure
5. Velocity
6. Mass
7. Force

8. Gravity
9. Work
10. Energy
11. Light
12. Sound
13. Magnetism
14. Electricity

Misconceptions in each of these fourteen areas are further analyzed in terms of minor concepts involved in these major concepts. Due representation is given to each major concept according to the number of minor concepts involved to conceive the corresponding major concept. Hence, the numbers of test items vary with respect to each concept misconceptions tested using Test of Concept Attainment in Physics (TCAP). TCAP (Long version) is designed to identify misconceptions in the concept areas of secondary school physics, which includes the major areas such as (1) Matter (2) Solar System (3) Density (4) Pressure (5) Velocity (6) Mass (7) Force (8) Gravity (9) Work (10) Energy (11) Light (12) Sound (13) Magnetism and (14) Electricity. The survey part helped identifying the extent of errors in each area in various sub samples namely gender and locality of the total sample.

### **Design of Study in Phase 1**

First phase of the study used a survey method. Survey was conducted among standard VIII secondary school students of Malappuram, Kozhikode, and Kasaragod districts of Kerala state. In the survey phase, permission was obtained from the heads of the concerned schools for administering the tool. The test was administered with the help and cooperation of the respective class teachers. The Test of Concept Attainment in Physics and response sheet were distributed. The students were asked to mark their responses in the space provided in the response sheets using tick marks.

### **Tools Used**

Based on the literature review, consultation with teachers and by analyzing content of science textbooks in primary and secondary schools, major and minor concepts in school physics that are prone to misconceptions were identified. Misconceptions in the minor concepts were tested through true-false items in the form of statements. For the present study, the investigator has used the following tools for the collection of data.

- 1) Test of Concept Attainment in Physics - Longer version (TCAP)  
(Gafoor and Akhilesh, 2010)

In addition to this test of concept attainment, the following tools were used in the experimental phase

- 2) Instructional Programmes on Remediation of the Misconcepts (Gafoor and Akhilesh, 2012)
- 3) Test of Concept Attainment in Physics - Abridged Parallel versions (TCAP) (Gafoor and Akhilesh, 2010)

### **Test of Concept Attainment in Physics - Longer Version (TCAP) (Gafoor & Akhilesh, 2010).**

Test of concept attainment in physics - Longer Version was employed in the survey phase of the study. This was constructed by the investigator with the guidance of the supervising teacher. The objective of the test was to identify the extent of misconception regarding the major areas in physics among secondary school students. The investigator prepared Test of Concept Attainment in Physics composed of 98 items. After tryout, the items were reduced to 80. These 80 items representing 80 minor concepts come under 14 major concepts in physics.

***Planning of the test and defining the content domain.***

As pilot study, investigator did several informal interviews with eight high school teachers, sixteen high school students, and an experienced college teacher of physics. The investigator also referred the Internet, text books, high school and upper primary school teachers and peer teachers. These frequent informal but valuable consultations helped to obtain a long list of misconceptions, which was crosschecked through discussions with a number of school students upon confirming their relevance for inclusion in attest of misconceptions in physics. After the verification of occurrence of misconceptions among students, a detailed related literature survey on the topics of misconceptions was done. This literature review helped to prepare a condensed list of important areas in physics where misconceptions occur frequently.

***Format of test items.***

The investigator through a detailed review of related literature found that there were three types of tests used to find the areas where misconceptions persisted. They are:

***Multiple choice tests.***

Example of an item – What is force? Given choice alternatives are (a) Force is something applied to people. (b) An external force that changes the state of rest or state of motion of an object (c) Capacity to do work.

***Diagnostic test.***

It is used to find out minor concepts in limited areas. Example – Diagnostic test to reveal the misconceptions about the lunar phenomena, items with very minute concepts about the lunar phenomena, were included.

*Statement form questionnaire.*

Example – a) Energy never decreased in Sun and b) We can see different sides of moon from Earth.

From these three types of questions used as a conventional practice, investigator developed multiple choice test items. A pilot test was conducted in 20 students and recognized that selections of alternatives were not only based on the misconception regarding the area for which the item stands for; but based on misconceptions about the facts and concepts also on which the alternatives are made. Therefore, the format was converted into statement form and the pilot test was repeated. It is observed that students are more willing and co-operative towards this item format. This format has also helped to sustain the interest of the students throughout the test.

*Length of the test.*

Two important factors were considered in deciding the length of the test. They are (1) content areas to be included to check misconceptions and (2) time duration for the implementation of the test. Considering these two factors, the investigator decided to limit the testing time to a maximum of one hour.

*Item writing.*

Items were prepared with regard to the areas selected by the interview with teachers, students, peers of investigator and review of related literature. A draft test of 110 items in statement form was first prepared. Statements with complex structures were edited and some were eliminated. Editing was done for avoiding difficulties such as language confusion, multiplicity in answering options and complex sentence structure. The draft test with 98 items was finalized for try out. The draft test is shown in Appendix IA & B.

***Finalization of the TCAP.***

The draft test of concept attainment in physics with 98 statements true false items were given to six experienced high school teachers of physics for validation of items. Only those items that all the six experts agreed to as appropriate for testing misconceptions in the relevant minor concept were retained for the final test. After this step to ensure content validity and contextual validity, only 80 items were obtained for the final version of TCAP.

Table 1 shows the item numbers representing minor concepts corresponding to the major concept area in Physics.

Table 1

*Item Number which are Representing Minor Concepts Corresponding to the Major Concept Areas in Physics*

Sl. No.	Major Concept	Item number of Minor Concepts in TCAP	Number of Item/Major Concept
1	Matter	1-5	5
2	Solar system	6-12	7
3	Density	13-19	7
4	Pressure	20-21	2
5	Velocity	22-31	10
6	Mass	32-36	5
7	Force	37-39	3
8	Gravity	40-45	6
9	Work	46-49	4
10	Energy	50-55	6
11	Light	56-64	9
12	Sound	65-72	8
13	Magnetism	73-75	3
14	Electricity	76-80	5

Different aspects of the test construction, namely, the formation of objectives, item construction for the test, nature of instruction, time allotted, and methods of answering have been studied critically by conducting a pilot test to a small sample. For this purpose, the preliminary draft test was administered to randomly selected pupils. Besides the written direction given in the test, oral instructions were also given to each pupil. They were provided with separate response sheets. The investigator noted the time taken for the completion of the test. By taking its average, the time for the test was finally fixed as 1 hour. Pilot test was also used for screening out discrepancies, which crept in the construction, assembling test items, in the instructions given and in detecting the ambiguity. After pilot testing, the test was again edited and the final test was prepared in a booklet form along with the response sheet. The scoring key was also prepared. The final test, response sheet and answers are given in Appendices...

#### **Validity of the test.**

The validity of the test constructed (TCAP) is verified by face validity. Basic to the validity of questionnaire is asking the right questions phrased in the least ambiguous way. In other words, to see whether the items sample a significant aspect of the purpose of the investigation. Regarding the validity of TCAP, the investigator assured face validity and item wise validity.

To ensure the item wise validity while construction of the test, meaning of all terms were clearly defined so that they have the same meaning to all respondents.

Regarding the face validity of the test, researcher utilized all the help he can get i.e., suggestions of colleagues and experts in the field of physics to avoid ambiguities in the test. A panel of experts including experienced teachers, researchers in this field and peer teachers checked and rated the validity of the test items.

Finally, during the pilot run, investigator ensured the validity of each item by crosschecking response to each item with the actual answers and believes of students. In addition, investigator sought explanation for particular responses. Putting these responses obtained from the students against each item responses, the investigator made sure that the responses given could be used to tackle and identify the desired misconception in the respective areas.

### **Scoring.**

Misconceptions were scored by counting false response to each item in TCAP.

### **Sample for the Survey Phase**

The population for the present study is secondary school students in Kerala. This is a very large population. Therefore, the investigator confined his study to a sample of the total population.

The sampling was done as follows. The investigator selected stratified sampling technique for selection of the sample giving due representation to the sub groups based on gender of the pupils and locality of schools.

### **Factors considered in the sampling.**

Factors considered in the sampling are gender of students and locality of the schools. Literature review reveals that gender has a prominent role in committing mistakes while understanding a novice idea especially in science and its application. Hence, the difference, between boys and girls in problem solving abilities and in abilities to learn physics concepts. Based on this rationale, investigator considered gender of the students as attribute variable and also as a factor to be considered while sampling.

There are differences between urban and rural schools in the chances to get opportunities to understand with concrete examples, school facilities such as

library and laboratory and of course to the daily life experiences which foster the understanding of science in daily life. During the informal interviews with teachers, they noticed the difference in locality of students in familiarizing many ideas from daily life. They quoted the lesson of “science in daily life” of eight standard. Certain common notions to some students appeared as unknown to the rest. So the investigator purposefully selected sample giving due representation to the locality of school, where majority of the students are attending from the premises itself. Hence, locality of schools is considered while sampling.

The study was confined to the VIII standard students taken as a representative sample of the three secondary school classes VIII, IX and X.

#### **Size of the sample.**

Though it was proposed to sample 500 eighth standard students in Kerala through appropriate methods for selecting a representative sample of the population, after tabulation, the sample size was reduced to 467 after discarding the incomplete responses. Breakup of the survey sample is in Table 2

Table 2

#### *Break Up of Sample Used in Survey Phase*

Gender	Boys	210	467
	Girls	237	
Locale	Rural	315	467
	Urban	152	
Total		467	

A sample of 467 pupils from eight schools situated in Malappuram, Kozhikode and Kasargod districts of Kerala state was selected by adopting the above-mentioned procedure. Pupils of standard VIII was taken as representative of secondary school students. Details of the final sample on which the study was conducted is given in Table 3.

Table 3

*School wise Distribution of the Final Sample Used in Survey Phase*

Sl. No.	Name of School	Rural/ Urban	No. of Boys	No. of Girls	Total
1	Pantheerankav H.S., Calicut	Rural	27	40	67
2	Kolathoor H.S.S., Calicut	Rural	30	39	69
3	Elathur H.S., Calicut	Rural	40	48	88
4	VPKMMHSS, Puthur Pallikkal, Malappuram	Rural	19	33	52
5	Rajas HSS Kottakkal, Malappuram	Rural	--	39	39
6	Govt model H.S.S. Calicut	Urban	50	--	50
7	Zamorians H.S.S. Thali, Calicut	Urban	29	26	55
8	GGHSS Kasargod	Urban	15	32	47
Total			210	257	467

**Data Collection Procedure during Survey Phase**

In the survey phase, permission was obtained from the heads of the concerned schools for administering the tool. TCAP was administered with the help and corporation of the respective class teachers. Test of Concept Attainment in Physics (TCAP) and response sheets were distributed among the pupils. The students should mark on any one of the two response types given against each statement. The space of response was provided in the response sheet. The response for all statement have restricted with form of a ✓ or × mark on the appropriate response column against each statement.

**Scoring and consolidation of data.**

Scoring key was used to score the Test of Concept Attainment in Physics. Item wise scoring was done for the entire response sheets collected from the sample. The item wise response of each element in the sample was entered into a computer spreadsheet to facilitate analysis of the data. The frequency of false responses on each item representing a minor concept indicated the extent of misconception on that minor concept.

### **Identification of Misconcepts in Physics among Secondary School Students**

Extent of misconception in physics among secondary school students were analyzed in terms of (i) misconceptions on fourteen major concepts in physics, and (ii) misconceptions on the minor concepts within these major concepts. The percentage of students responded incorrectly was found on each item in the Test of Concept Attainment in Physics (TCAP) on physics concepts, representing minor concepts in physics. This is denoted as percentage of error. Extents of misconception on major concepts were estimated as mean percentage of incidence of misconception in the respective minor concepts by averaging the rate of misconceptions on all of the minor concepts involved in a given major concept.

### **Phase 2: Intervention for Remediating the Misconceptions in Physics**

The experimental part included the administration of selected strategies of conceptual change to the experimental group. The control group received no treatment. The experiment was conducted in the third quarter of academic year. Hence, most of the lessons were taught to the students by their concern teachers using conventional practices in teaching physics in secondary schools. Since the topics were already taught, the investigator planned not to implement conventional or any other strategy to the control group. Instead, students were encouraged to revise the portions covered in school. Students in the control group were also intimated about conduction of pre and posttests for research purpose. Students cooperated well with genuine enthusiasm.

### **Variables in the Experimental Phase**

The experimental phase of the study constitutes independent variable and dependent variable. This phase involves testing the effectiveness of select interventions for remediating the misconceptions identified during the survey phase. Hence, this phase has identified independent and dependent variables.

#### **Independent variable.**

The independent variable of the study is instructional method for remediation of misconception referred to as remedial instruction programme.

This variable has two levels, the remedial instruction programme, and a no treatment control. This programme is constituted as an eclectic set of instructional strategies chosen from previous researches, subject to the judgment that such strategies fit to the paradigm of education and infrastructural facilities in schools of Kerala. Specifically, three conceptual change strategies were employed as instructional programmes for remedying misconceptions in physics. They were conceptual change strategy, concept mapping, and participative approach.

Thus, in addition to the effect of total instructional programmes on total concept attainment in physics, the effect of the three strategies individually and in combination on the concept attainment in select areas of physics were studied as follows.

- i. The effect of Conceptual change strategy on Concept attainment in Pressure
- ii. The effect of Concept mapping strategy on Concept attainment in Motion
- iii. The effect of Participative approach on Concept attainment in Sound
- iv. The effect of Conceptual change cum concept mapping strategy on Concept attainment in Force, Density, Magnetism, Light, and Electricity

Hence, the independent variable, remedial instructional programme has four sub-independent variables viz.,

- i. Conceptual change strategy (Vs. no treatment control)
- ii. Concept mapping strategy (Vs. no treatment control)
- iii. Participative approach (Vs. no treatment control)
- iv. Conceptual change cum concept mapping strategy (vs. no treatment control)

**Dependent variable.**

The dependent variable of the study is concept attainment in physics. This variable is quantified as the inverse of misconception in physics. The concept attainment in physics in total and concept attainment in four broad areas of physics were analyzed for studying the effectiveness of select set of instructional strategies. The four subset of dependent variables thus studied were:

- i. Concept attainment in Pressure,
- ii. Concept attainment Sound,
- iii. Concept attainment Motion, and
- iv. Concept attainment in force, Density, Magnetism, Light, and Electricity.

These variables, as mentioned earlier, were quantified as inverse of misconception in these areas.

### Experimental Design

The experimental design followed is quasi-experimental– pretest posttest matched control group design

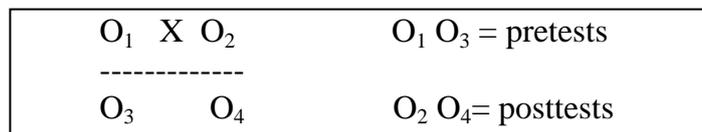

Figure 2. Design: Quasi-Experimental Pretest Posttest

### Tools Used in the Experimental Phase

Experimental phase of the study employed the following tools.

- 1) Lesson Transcripts for Conceptual Change (Gafoor & Akhilesh, 2012)
- 2) Test of Concept Attainment in Physics – Abridged Parallel Versions (TCAP) (Gafoor & Akhilesh, 2012 )

#### **Test of Concept Attainment in Physics - Abridged Version (TCAP) (Gafoor & Akhilesh, 2012).**

The experimental phase started with the administration of test of concept attainment in physics-abridged version, which included 40 test items covering eight major concepts in physics about which the secondary school pupils of eighth standard are familiar. The prepared item is an abridged version of TCAP administered in survey phase. Since the VIII standard syllabus of Kerala state covers only eight major concepts out of 14 selected in survey phase investigator proposed abridged version, giving due representation to minor concepts required to transact major idea. They are (1) Light (2) Force (3) Motion (4) Static

electricity (5) Liquid pressure (6) Magnetism (7) Sound and (8) Density in which ‘Static Electricity’ and ‘Liquid Pressure’ are intentionally derived from minor concepts of the major heads of ‘Electricity’ and ‘Pressure’ included in survey phase or TCAP (Longer version). Hence, the total number of items is limited to forty and the duration of test is fixed to 15 to 20 minutes. The final forms of administered Abridged TCAP in English and Malayalam versions are given as Appendices .....

The details of test items and concepts included in pretest are as follows.

Table 4

*Concept Areas and Their Weight ages in Abridged Version of Test of Concept Attainment in Physics (Abridged Version) Used in Experimental Phase*

Sl. No.	Concept	Item nos	Marks /(weightage)
1	Light	6(1-6)	6 (15%)
2	Force	8(7,8,10,13,14,15,16,17)	8(20%)
3	Motion	4(9,11,12,18)	4(10%)
4	Static electricity	4(24-27)	4(10%)
5	Liquid pressure	4(19-23)	5(12.5%)
6	Magnetism	7(28-34)	7(17.5%)
7	Sound	4(35-39)	4 (10%)
8	Density	2(39,40)	2(5%)

#### **Instructional Programmes on Remediation of the Misconcepts (Gafoor & Akhilesh, 2012).**

The experimental phase started with the administration of Test of Concept Attainment in Physics. It included 40 test items covering eight major concepts in physics about which the secondary school pupils of eighth standard are familiar. The investigator prepared lesson transcripts based on conceptual change strategies to eradicate the misconceptions among students-

The conceptual change strategies administered on experimental group include Participative Approach, Conceptual Change Strategy based on Posner et al, Concept Map and A Combination of Concept Map and Conceptual Change Strategy.

Conceptual change theories get their roots from the constructivist theory of Piaget and social constructivist theory of Vygotsky. The philosophy of these theorists gives abroad perspective on how individuals construct concepts and has influenced the design of this study. Piaget proposed that an individual constructs his own knowledge by adapting his initial ideas and theories while engaged with the environment, either the physical environment or through social transmission (Piaget, 1970). Using the terms *assimilation*, *accommodation*, *disequilibrium*, and *equilibration*, Piaget explains how conceptual development requires action on the environment, bringing exposure to new experiences or ideas. For children, these actions must include concrete experiences with the physical environment. *Assimilating* new experiences into current thinking may cause a state of *disequilibrium*, if the new way of thinking does not fit current conceptual understandings. *Accommodation* of thinking is necessary to again reach equilibrium, a process Piaget calls *equilibration*. According to Piaget, assimilation and accommodation always work together in the development of conceptual understanding. A well-established theory of conceptual change developed by Posner, Strike, Hewson, and Gertzog (1982) is derived from Piaget's theory of constructivism. Similar to the definitions of Piaget, Posner et al. (1982) defined assimilation as a process where students use existing concepts to deal with new phenomena and accommodation as a radical process in which students must replace and reorganize their prior concepts. In their conceptual change theory, Posner et al. (1982) define four conditions under which conceptual change occurs. These conditions are:

1. There must be dissatisfaction with existing conceptions.
2. A new conception must be intelligible.
3. A new conception must appear initially plausible.

4. A new concept should suggest the possibility of a fruitful research programme.

A summary of the three-experiental remedial instructional strategies employed in this study is given in Table 7.

Table 7

*Outline of Conceptual Change Strategy, Concept Mapping and Participative Approach Applied in Experimental Group*

Dimensions of the strategy	Conceptual change	Participative approach	Concept Map
Major phases	<ol style="list-style-type: none"> <li>1. <u>Preliminary</u> – phase- giving situations, phenomena etc</li> <li>2. <u>Challenging</u> phase-prediction and justification by students</li> <li>3. Activities based on (1)</li> <li>4. <u>Consolidation</u> phase - contrasting by teacher</li> </ol>	<ol style="list-style-type: none"> <li>1) Identification</li> <li>2) Giving activity</li> <li>3) Students doing activity</li> <li>4) Consolidation by teacher</li> </ol>	<ol style="list-style-type: none"> <li>1) Learning to construct concept map through -brain storming -organizing concept -lay out -linking phase -final map</li> <li>2) Explains various phenomena, situations, theories and laws etc.</li> <li>3) Students structure concept map</li> <li>4) Evaluation of concept map</li> </ol>
Nature of class	Structured in phase (1) & (4)	Semi structured	Structured
Student activity	Predict and justify given situations	Learning through activities.	Learn to structure and categorize concepts Evaluation by contrasting the maps and ideas in last phase
Evaluation	Evaluation In each step	Evaluation after activities	Evaluation by contrasting the maps and ideas in last phase
Role of teacher	Facilitator and consolidator	Facilitator and consolidator	Facilitator

Table 7 gives a brief outline of the strategies employed in standard VIII class for remediation of misconception in Physics. Researcher selected strategies according to the suitability of the topic based on reviewed literature.

Table 8

*Details of strategies used for conceptual change*

Concept area	Topic	No. of periods	Strategies used
1) Force	Newton's laws of motion	4	Concept mapping
2) Pressure	Pascal law	1	Concept mapping
	Liquid pressure	1	Conceptual change strategy
3) Magnetism	Magnetic field	1	Conceptual change strategy
	Electromagnetic field	1	Conceptual change strategy
4) Static Electricity	Static electricity	2	Concept mapping
5) Density	Relative density	1	Concept mapping
6) Motion	Distance travelled and displacement	1	Concept mapping
7) Light	Refraction	1	Conceptual change strategy
	Different Colours of light	1	Conceptual change strategy
	Blue colour of sky	1	Conceptual change method
8) Sound	Production of sound and propagation	2	Participative approach

### **Establishing Validity and Reliability of the Tools**

The abridged version of the TCAP is but a part of the longer version, limited to the eight concept areas of physics in standard VIII on which the experimental treatment were applied. The validity of these items and test were already described along with the longer version.

The reliability of Test of Concept Attainment in Physics (TCAP) is established using a parallel tool. The same is administered over a sample of 48 students. The score on parallel form was correlated with the actual test administered. The reliability co- efficient so obtained is 0.681(N=48) which established significant relation between two parallel tests. Hence, the test (abridged version) is considered a reliable and valid tool for measuring concept attainment in physics among standard VIII students.

### **Experimental Sample**

The experimental sample consists of equal number of students in experimental group and control group i.e. 47 students in each group, with comparable academic achievement and levels of misconceptions in physics.

<u>Experimental</u>	Boys	15	Total = 47
	Girls	32	
<u>Control</u>	Boys	16	Total = 47
	Girls	31	

### **Matching the control groups and experimental group on concept attainment.**

The investigator selected three intact groups randomly from the same school for the present study one experimental and two control groups. After administering the pretest which contain minor concepts of select major

concepts such as (1) Matter (2) Solar System (3) Density (4) Velocity (5) Mass (6) Gravity (7) Work (8) Energy (9) Light (10) Sound (11) Electricity (12) Force (13) Pressure and (14) Magnetism to both groups, the groups were matched based on gender and obtained a correlation co-efficient of 0.987 .The investigator selected two matched groups of eight standard students for the present study. For this, administration of the pretest of conceptual attainment in physics was done to three intact groups of eight standard students. One group was randomly assigned as experimental group. The students in the other two intact groups were chosen for control group by applying the criteria of matching on the pretest scores of an individual of the same gender in the experimental group. Thus, forty-seven students matching on pretest scores of conceptual understanding in physics and gender were obtained in the experimental and control groups. However, two individuals in the control group had one score each above their counterparts in the experimental group. Thus, the two groups were matched based on gender and score on conceptual understanding in physics prior to intervention. The correlation between the two groups on pretest scores on conceptual understanding in physic is 0.99 (N=47,  $p<.01$ ). It shows that the experimental and comparison groups are 99% matching in academic aspects and there is no significant difference between the experimental and control groups on pretest scores of conceptual attainment in physics.

### **Implementation of the experiment.**

During the experimental part, the Test of concept attainment in physics was conducted as pretest, then remedial conceptual change programmes were applied in experimental group with no treatment to the control group, and the posttests were applied in both groups.

### **Statistical Techniques Used for Analysis**

The statistical techniques used for analyzing the responses were

#### **Percentage analysis.**

Percentage analysis was done to find out the percentage of students who have given a wrong response for each item in the test in survey phase.

#### **Two tailed test of significance of difference between two proportions for large independent samples.**

Two tailed test of significance of difference between two proportions for large independent sample is calculated using the formula.

$$CR = \frac{P_1 - P_2}{\sqrt{PQ \left[ \frac{1}{N_1} + \frac{1}{N_2} \right]}} \text{ (Garrett 1996)}$$

Where, CR = Critical Ratio

$P_1$  = Proportion of wrong answer for the first group

$P_2$  = Proportion of wrong answer for the second group.

$N_1$  = Number of samples in the first group.

$N_2$  = Number of samples in the second group.

$$P = \frac{P_1 N_1 + P_2 N_2}{N_1 + N_2}$$

$$Q = (1 - P)$$

#### **Paired T-test of significance of difference between two means (one tailed test).**

A paired sample t-test is used to determine whether there is a significant difference between the average values of the same measurement made under two different conditions. Both measurements are made on each unit in a sample, and

the test is based on paired differences between these two values and is calculated using  $S = \frac{\sum \text{differences}}{\sqrt{((N \sum \text{differences}^2 - (\sum \text{differences})^2) / (N-1))}}$ .

$$\text{i.e., } S = \frac{\sum d}{\sqrt{\frac{\sum (x - M)^2}{n - 1}}}$$

d = Paired difference

n = Population

x = Sample mean

M = mean

## ANALYSIS

- 
- ↪ **EXTENT OF MISCONCEPTION ON PHYSICS AMONG SECONDARY SCHOOL STUDENTS**
  - ↪ **PERCENTAGE OF MISCONCEPTION ON THE MAJOR CONCEPTS IN PHYSICS.**
  - ↪ **PERCENTAGE OF MISCONCEPTION ON THE MINOR CONCEPTS IN PHYSICS**
  - ↪ **CONCEPT WISE PERCENTAGE OF INCIDENCE OF MISCONCEPTION IN 14 SELECTED CONCEPTS.**
  - ↪ **EXTENT OF INCIDENCE OF MISCONCEPTION ON THE MINOR CONCEPTS OF PHYSICS**
  - ↪ **COMPARISON OF PROPORTIONS IN SUBSAMPLES**
    - **BASED ON GENDER**
    - **BASED ON LOCALE**
  - ↪ **EFFECTIVENESS OF INSTRUCTIONAL PROGRAMMES FOR REMEDIATION OF MISCONCEPTS IN PHYSICS**
-

The present study on identification of misconceptions in physics and testing of effectiveness of certain instructional programmes on remediation of the misconceptions among VIII standard students in Kerala employed two major statistical techniques, one for analyzing data and the other for testing the hypotheses. They were percentage and mean difference analyses (of percentages), and tests of significance of difference between means.

### **Extent of Misconceptions in Physics among Secondary School Students**

Extent of misconceptions in physics among secondary school students were analyzed in terms of (i) misconceptions on fourteen major concepts in physics, and (ii) misconceptions on the minor concepts within these major concepts. This was done as follows. The percentage of students responded incorrectly was found on each item in the Test of Concept Attainment in Physics (TCAP) on physics concepts, representing minor concepts in physics. This is denoted as percentage of error in the descending order of percentage error. Extents of misconception on major concepts were estimated as mean percentage of incidence of misconception in the respective minor concepts. This was obtained by averaging the rate of misconceptions on all of the minor concepts involved in a given major concept.

### **Percentage of Misconceptions on the Major Concepts in Physics among Secondary School Students**

The 14 concepts in physics were ranked based on the mean percentage of incidence of misconception obtained for each of them among standard eight students in the secondary schools of Kerala. Mean percentage of incidence of misconception was calculated by averaging the rate of misconception for all the minor concepts involved on the given major

concept. The ranked incidence of misconception in a major concepts helps to identify the areas of high school physics that are comparatively prone to misconception among students.

Table 9

*Concept Wise Percentage of Incidence of Misconception on Selected Major Concepts*

Sl. No	Concept in Physics		Extent of error in total (%)
1	Matter		70.11
2	Magnetism		66.82
3	Electricity		65.15
4	Pressure		58.11
5	Gravity		55.76
6	Density		52.67
7	Sound		50.02
8	Solar system		49.74
9	Light		48.92
10	Mass		47.91
11	Energy		46.87
12	Velocity		45.34
13	Work		40.9
14	Force		23.38

*Note :* The icon colours indicate high rate (red), moderate rate (yellow) and modest rate (green) of misconception

Table 9 shows concept wise percentage of incidence of misconception in 14 selected major concepts in physics among the secondary school students arranged in descending order of percentage of misconception. Students have more misconceptions regarding the major concept 'Matter' where as they are least misconceived about the concept of Force. Concept area of Magnetism, which is ranked as two, has 67 % of misconceived ideas and followed by Electricity with 65% of error, Pressure with 58% of misconceptions, Gravity of

56%, Density of 53% and Sound has 50% of errors. These are the concept areas, which showed more than 50% of misconceptions.

Among the remaining of seven major concept areas, six concepts have errors below 50%. These concepts along with misconception rate are Solar System 49.74%, Light 48.92%, Mass 47.91%, Energy 46.87%, Velocity 45.34% and Work 40.92%.

The concept of Matter shows the highest percentage of misconception (70 percent), whereas the concept of Force showed the least misconceptions (23 percent). In addition to Matter, six other conceptual areas, viz., Magnetism, Electricity, Pressure, Gravity, Density, and Sound demonstrate high rate (>50%) of misconceptions. Six major concepts namely solar system, light, mass, energy, velocity and work exhibit moderate rate (between 50 and 33% ) of misconceptions. Only one major concept in physics, i.e., Force, has the modest level (<33 %) of misconception.

The decrease in percentage of errors in a few areas might be due to familiarity from day to day experiences.

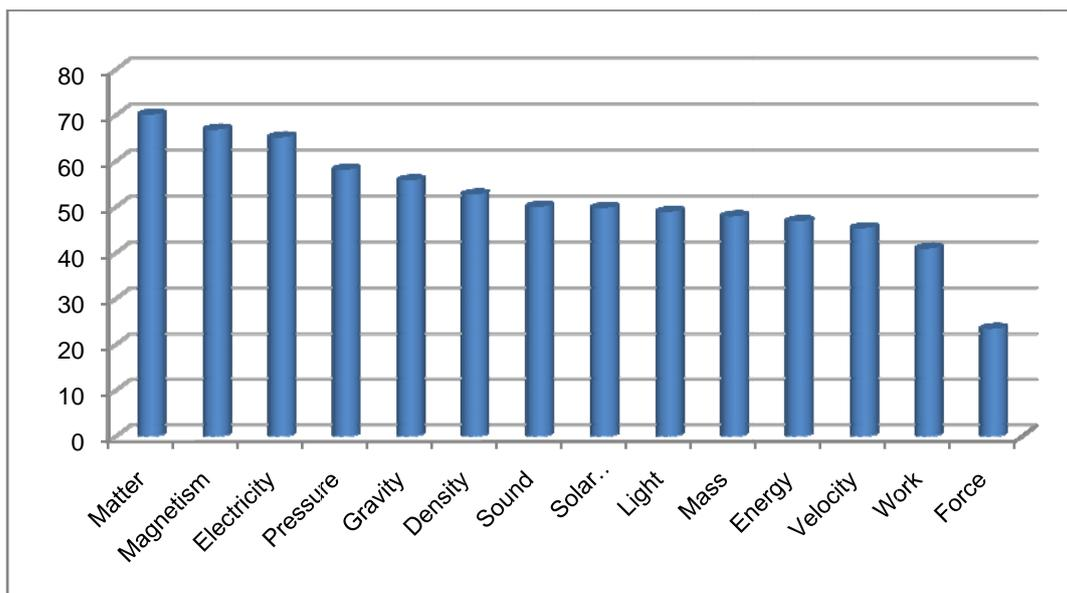

Figure 3. Bar diagram of extent of misconception in major concepts in physics among secondary school students

Table 9 along with Figure 3 demonstrate that almost all of the 14 major concepts in physics, except the 'Force' have high to moderate rate of misconception. Seven concepts, out of fourteen studied have misconception rate above 50 percent. These concepts are Matter, Electricity, Pressure, Gravity, Density, and Sound. The other six concepts viz., Solar System, Light Mass, Energy, Velocity, and Work are also having misconception in the range of 50 to 40 percent. The only concept with relatively fewer misconceptions is Force.

### **Percentage of Misconception on the Minor Concepts in Physics among Secondary School Students**

To find out the extent of misconceptions on each minor concept for the fourteen selected major concepts in physics, the percentage of students who responded to the corresponding item wrong were identified. This is denoted as percentage of misconception on the minor concepts.

The extents of misconception on minor concepts of physics vary from 91% to 6%. Minor concepts were arranged in rank order of extent of misconception obtained for each of them among the secondary school students in Tables 10 to 12.

Table 10

*Minor Concepts in the rank order of Percentage of Misconception in the Areas of Matter, Solar System, Density and Pressure*

Concept	Minor concepts	% of misconception
Matter	1)Gases are not matter, because they are invisible	 67.3
	2)Gases are mass less	 90.93
	3)Air is matter	 69.69
	4)Metals can occur in solid state only	 51.79
	5)On evaporation Water gets converted into oxygen and hydrogen	 70.88
Solar system	6) energy of sun never ceases	 55.6
	7)Sun is not a star	 42.72
	8) The same side of moon is always seeing from earth	 60.38
	9)We see one face of moon from India and the other from America	 52.74
	10) Moon has its own light	 40.81
	11) All stars have same size	 25.06
	12) Brightness of stars depends only on the distance from earth	 70.88
Density	13) some substances floats in water since they are lighter than water	 67.54
	14) low density substances float in water	 21.48
	15) the reason behind floating of ice is the presence of air inside	 58.71
	16) water and oil are immiscible so oil floats over water	 83.53
	17) substance should contain air to float	 63.24
	18) Due to its heaviness a big cube ice can't float.	 42.24
Pressure	19) Density and volume influences floating of bodies.	 31.98
	20) Atmospheric pressure increases with altitude	 68.01
	21) Pressure in sea bed will be too less than surface	 48.21

Table 10 shows that the majority of students have the following misconceptions in the area of **Matter**.

Gases have no mass (90.93%).

Gases are not matter (67.3%).

Air is not a form of matter (69.69%).

No metals exist in the form of liquid (51.79%).

Water on evaporation is converted into oxygen and hydrogen (70.88%).

In the concept area of *Solar System*, the major misconceptions are as follows

Energy of Sun never ceases (55.6%),

One sees a face of moon from India and the other from America (52.74%),

The same side of moon is always seen from earth (60.38%).

In addition, more than 40 percent of students in secondary school have misconceptions that:

Sun is not a star (42.72%)

Moon has its own light (40.81%)

Regarding the area of *Density*, majority of students have misconceptions that,

Substances that are heavier or made of metals sink in water (42.24%),

Some substances float in water since they are lighter than water (67.84%),

The reason behind floating of ice is the presence of air inside (63.24%),

Water and oil are immiscible so oil floatation in water (83.53%),

Substance should contain air to float (63.24%),

Density and volume influences floating of bodies (31.98%).

In the area of *Pressure*, students have following misconceptions.

Atmospheric pressure increases with altitude (68.01%),

Pressure on sea bed is too less than that on surface (48.21%).

Table 11

*Minor Concepts in the order of Percentage of Incidence of Misconception in the Areas of Velocity, Mass, Force, Gravity and Work*

Concept	Minor concepts	% of misconception
Velocity	22) Motion is relative	 54.89
	23) Displacement and distance are same always	 51.31
	24) Increase in velocity is termed as acceleration	 31.98
	25) Velocity is the other name of speed.	 55.6
	26) Speed of an object is related to direction	 77.32
	27) Unit of speed and acceleration are same	 43.67
	28) Displacement is the total distance travelled by the object	 31.02
	29) Velocity is the distance covered in unit time	 29.11
	30) To have acceleration to a moving body its velocity should be increased	 33.17
	31) When velocity increases the mass of substance will change	 60.14
Mass	32) Mass is equivalent to weight of substance	 68.25
	33) Mass is the amount of matter in substance	 45.34
	34) Mass denotes size of the object	 17.9
Force	35) Force is that which can only apply by men	 18.13
	36) Force is the capacity to do work	 11.69
	37) Motion of an object can only be changed by force	 6.205
	38) Force is the entity which changes the state of motion or rest of an object	 18.13
	39) If an object is at rest there is no force acting on it	 62.76
gravity	40) Gravity is maximum at the centre of earth	 66.82
	41) Acceleration due to gravity is same everywhere	 36.27
	42) Two metallic objects with different size is allowed to fall from same height the heavier will reach first	 84.48
	43) Astronaut feel weightlessness due to low gravity	 14.08
	44) Gravity needs a medium to come in action	 66.58
	45) Without air (medium) gravity cannot act through	 66.34
Work	46) Work and labor are same	 66.11
	47) force is essential to do work	 7.159
	48) Work never take place against the applied force	 43.43
	49) Wherever force is acting work will be done there	 72.79

Note : The icon colours indicate high rate (red), moderate rate (yellow) and modest rate (green) of misconception

From Table 11, it can be found that the area of **Velocity** has the following misconceptions.

Motion is relative (54.89%),

Displacement and distance are always the same (51.31%),

Velocity is the other name of speed (55.6%),

Speed of an object is related to direction (77.32%),

Unit of speed and acceleration are same (43.67%).

In the area of **Mass** following misconceptions are perceived by students.

Mass is equivalent to weight of a substance (68.25%),

Mass is not the amount of matter in a substance (45.34%),

Mass denotes the size of the an object (17.9%),

Regarding the area of **Force**, students have the following misconceptions.

If an object is at rest, there is no force acting on it (62.76%).

Considering the area of **Gravity** majority of the students posses the following misconceptions.

Gravity is maximum at the centre of Earth (66.82%),

Acceleration due to gravity is the same everywhere (36.27%),

Two metallic objects with different size if allowed to fall from same height the heavier will reach ground first (84.48%),

Gravity needs a medium to come into action (66.58%),

Without air (medium) gravity cannot act through (66.34%),

In the concept area of **Work** students have the following misconceptions,

Work and labour are the same (66.11%),

Work never takes place against an applied force (43.43%),

Wherever force is acted work will be done (7.15%).

Table 12

*Minor Concepts in the order of Percentage of Incidence of Misconception in the Areas of Energy, Light, Sound, Magnetism, and Electricity*

Concept	Minor concepts	% of misconception
Energy	50) Energy is the capacity to do work	 15.03
	51) Different energy forms cannot be transformed to one another	 50.11
	52) object at rest do not possesses any energy	 63.72
	53) stationary object does not have potential energy	 47.25
	54) an object placed at a height possesses potential energy	 41.52
	55) energy and force are same	 31.74
Light	56) the surface which absorbs all colors of visible light appears in black where as the surface which reflects all the colors is seen in white	 69.92
	57) Pencil partially dipped in water will be seen slightly distorted.	 41.05
	58) light rays travel in straight line only	 34.12
	59) all rays in sunlight are visible	 12.64
	60) Seven colors of visible spectrum forms white light	 42.48
	61) Lakes and sea are found in blue color since they reflects sky	 67.54
	62) All rays of sunlight exhibit heating effect	 63
	63) light rays from an electric bulb travels faster than candle light	 85.44
	64) Light ray travelling through a lens focuses at its centre.	 24.1
Sound	65) Sound can do work	 35.8
	66) sound waves travel in straight line	 27.68
	67) object can make sound without vibration	 36.27
	68) Sound in air travels faster than that in solid	 75.17
	69) Sound needs no medium to travel	 44.63
	70) All kinds of sounds make the sense of sound in brain.	 42.48
	71) Sound wave of frequency more than 20Hz are audible	 84.01
	72) All sounds are audible to human ear	 35.8
Magnetism	73) only a magnet can produce magnetic field	 54.17
	47) Electricity can produce magnetic field	 91.4
	75) Smaller magnets are stronger than bigger ones	 86.87
Electricity	77) Pure water is a good conductor of electricity	 87
	76) Iron is the best conductor of electricity in nature.	 21.48
	78) in battery, electricity kept stored.	 49.16
	79) Static electricity is formed due to friction.	 44
	80) When materials are rubbed, electricity is produced due to exchange of charge.	 43

Note : The icon colours indicate high rate (red%), moderate rate (yellow%) and modest rate (green%) of misconception

Table 12 shows that in the area of **Energy** most of the students have the following misconceptions.

Objects at rest do not possess any energy (63.72%),  
Energy forms cannot be interchanged (50.11%),

Stationary objects do not have potential Energy (47.25%),  
Object at a height has potential energy (41.52%) .

Table 12 shows that in the concept area of **Light** following the misconceptions are perceived by students.

The surface that absorbs all colors of visible light appears in white, whereas the surface which reflects all the colors are seen in black (69.92%),  
Pencil partially dipped in water appear slightly distorted (41.05%),  
Seven colors of visible spectrum form white light (42.48%),  
Lakes and sea are found in blue color since they reflect sky (67.54%),  
Light rays from an electric bulb travel faster than candle light (85.44%).

In the concept of **Sound**, most of the students possess following misconceptions.

Sound in air travels faster than in solids (75.17%),  
Sound needs no medium to travel (44.63%),  
All kinds of sounds make the sense of sound in human brain (42.48%),  
Sound waves of frequency more than 20Hz are audible (84.03%),  
All sounds are audible to human ear (35.8%).

In the major concept area **Magnetism** students possess following misconceived ideas.

Only a magnet can produce magnetic field (54.17%),  
Electricity can produce magnetic field (91.4%).

Students have the following misconceptions regarding the concept of **Electricity**.

Iron is the best conductor of electricity in nature (21.48%),  
Pure water is a good conductor of electricity (49.17%).

Some interesting observations can be made from Table 12 which are listed below,

Students have lack of knowledge on:

- 1) Air is a form of matter (69.90 %).

- 2) Moon does not have light (40.81 %).
- 3) Gases have mass (90.93 %).
- 4) On evaporation water molecule is not converted into hydrogen and oxygen (70.88%).
- 5) Oil float over water due to difference in densities (83.53%).

Tables 10 to 12 have listed the minor concepts identified with misconceptions in the 14 areas of physics which range from 6 to 91 percentage.

Among the minor concepts, those in magnetism has highest percentage of error (91.40%) and those in Matter (90.93%) has the second highest error percentage. These are the areas having misconceptions higher than 90% error. This is followed by six minor concepts in areas such as Magnetism (86.87%), Light (85.44%), Gravity (84.48%), Sound (84%), Density (83.53%), and Electricity (82.33%), which have more than eighty percentages of misconceptions. Minor concepts in Velocity (77.32%), Sound (75.17%), Work (72.70%), Matter (70.86%), Solar System (70.88%), Light (69.92%), and Matter (69.68%) having error percentage above or just below to the mark of seventy percentage.

Mass (68.25%), Pressure (68.01%), Density (67.54%, 63.24%, 58.71%), Light (67.54%, 63.24%), Matter (67.30%), Gravity (66.82%, 66.58%, 66.34%), Work (66.10%), Energy ( 63.72%, 50.11%), Force (62.76%), Solar System (60.38%, 55.60%, 52.74%), Velocity |(60.14%, 54.89%, 51.31%) and Magnetism (54.17%) have minor concepts which lie in between 50 to 70% of misconception.

From Tables 10 to 12 one can also see the following results. 1) 39 minor concepts show misconceptions above fifty percent. 2) 70% of misconceived ideas are in the major concept areas such as Matter, Density, Velocity, Work, Sound, and Magnetism. 3) Minor concepts in concepts of Force, Work, Mass, Energy, Velocity, Light, Solar System show fewer percentages of misconceptions

among all the minor concepts. Minor concepts with fewer misconceptions are those related to daily life situations.

### **Comparison of Proportions in Subsamples**

Comparison of proportions in subsamples is described under the following categories.

#### **Comparison of Misconceptions in Major Concepts of Physics by Gender**

Test of significance of difference between percentages is used for the comparison between relevant sub samples on extent of misconception on the major and minor concepts.

The difference between the percentage scores of the comparable groups is tested using two-tailed test of significance of difference between percentages. For two-tailed test, critical ratio exceeding 2.58 is considered significant at .01 level and critical ratio exceeding 1.96 is treated as significant at .05 level.

Fourteen concepts in physics are ranked according to the extent of misconceptions in them for standard eight boys and girls in secondary schools of Kerala. The ranked extent of incidence of misconception in the major concepts helps to identify the areas of high school physics that are comparatively prone to misconception among boys and girls. Table 13 and Table 14 respectively show extent of misconception in the major concepts of physics for standard eight boys and girls.

Table 13

*Concept Wise Percentage of Incidence of Misconception in Selected Concepts among Boys*

Sl. No	Concept	Extent of misconception in boys (%)	
1	Magnetism		67.47
2	Matter		66.95
3	Electricity		62.51
4	Gravity		54.66
5	Light		50.5
6	Pressure		50.48
7	Sound		49.45
8	Density		49.13
9	Solar system		48.37
10	Energy		47.53
11	Velocity		46.59
12	Mass		43.35
13	Work		38.64
14	Force		21.35

*Note* : The icon colours indicate high rate (red), moderate rate (yellow) and modest rate (green) of misconception

According to Table 13, the concept of Magnetism shows highest percentage of misconceptions (67 percent). The concept of Force showed the least misconceptions (21 percent). In addition to Magnetism, five other conceptual areas, viz., Matter, Electricity, Gravity, Light, and Pressure demonstrate high rate (>50 percent) of misconceptions. Seven major concepts namely Sound, Density, Solar System, Energy, Velocity, Mass, and Work exhibit moderate rate (between 50 and 33 percent) of misconceptions. Only one major concept in physics, i.e., Force, has modest level (<33 percent) of misconception.

Table 14

*Concept Wise Percentage of Incidence of Misconception in Selected Concepts among Girls*

Sl. No	Concept	Extent of misconception in girls (%)
1	Matter	 73.2
2	Electricity	 67.73
3	Magnetism	 66.19
4	Pressure	 65.56
5	Gravity	 56.83
6	Density	 56.13
7	Mass	 52.35
8	Solar system	 51.07
9	Sound	 50.58
10	Light	 47.37
11	Energy	 46.22
12	Velocity	 44.12
13	Work	 43.11
14	Force	 25.37

*Note* : The icon colours indicate high rate (red), moderate rate (yellow) and modest rate (green) of misconception

Table 14 shows that, among girls, the concept of matter shows the highest percentage of misconceptions (73.20 percent). The concept of force showed the least misconceptions (25.37 percent). In addition to Matter, eight other conceptual areas, viz., Magnetism, Electricity, Pressure, Gravity, Density, Mass, Solar System and Sound demonstrate high rate (>50 percent) of misconception. Four major concepts namely, Light, Energy, Velocity and Work exhibit moderate rate (between 50 and 43 percent) of misconceptions. Only one major concept in physics, i.e., Force, has modest level (<33 percent) of misconception.

Table 15

*Comparison of Percentage of Misconceptions on the Major Concepts in Physics among Boys and Girls of Secondary School*

Sl. No	Major Concept	Extent of misconception (%)		Critical Ratio
		Girls (N=237)	Boys (N=210)	
1	Matter	73.20	66.95	1.39
2	Solar system	51.07	48.37	0.60
3	Density	56.13	49.13	1.56
4	Pressure	65.56	50.48	3.37**
5	Velocity	44.12	46.59	0.55
6	Mass	52.35	43.35	2.01*
7	Force	25.37	21.35	0.89
8	Gravity	56.83	54.66	0.48
9	Work	43.11	38.64	0.99
10	Energy	46.22	47.53	0.29
11	Light	47.37	50.50	0.69
12	Sound	50.58	49.45	0.25
13	Magnetism	66.19	67.47	0.28
14	Electricity	67.73	62.51	3.11**

\*\*p<.01; \*p<.05

Table 15 shows that the critical ratios obtained for the test of significance of difference between percentages of misconception on the major concepts among boys and girls are not significant, except for three major concepts viz., Pressure, Mass and Electricity. There are significantly higher percentages of misconception among girls, than boys, in the major concepts of Pressure (Girls, 65.56%; Boys, 50.48%, CR =3.37; p<.01), Mass (Girls, 52.35%; Boys, 43.35%, CR = 2.01; p<.05) and Electricity (Girls, 67.73%; Boys, 62.51%, CR=3.11; p<.01). There is no significant difference in percentage of misconception among boys and girls in the eleven major concepts viz., Matter, Solar System, Density, Velocity, Force, Gravity, Work, Energy, Light, Sound, and Magnetism (p>.05).

Figure 4 shows a comparison of extent of misconception on the major concepts of physics by gender.

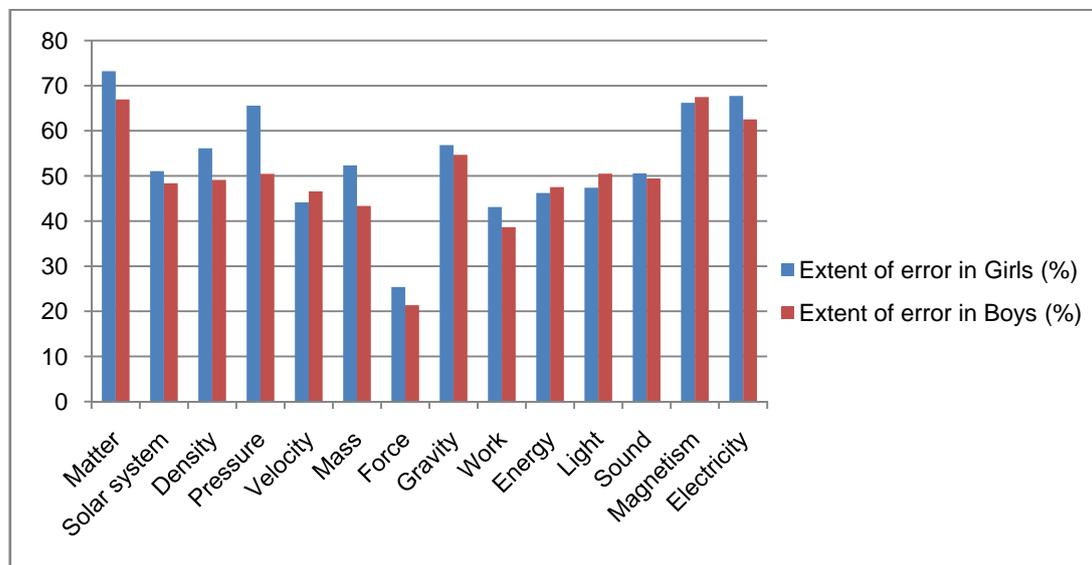

Figure 4. Cluster bar diagram of extent of misconception in major concepts in physics among secondary school students by gender

### Gender Wise Comparison of Extent of Misconceptions on Minor Concepts in Physics

Though only three major concepts demonstrate gender difference in the misconception in physics, gender wise comparisons of extent of misconceptions on minor concepts in physics are done assuming that gender wise difference in misconception in minor concepts may be neutralized if a few minor concepts are higher in one gender and others are higher in the other gender. The minor concepts regarding the misconceptions of which there is significant difference between boys and girls are identified by estimating the critical ratio of significance of difference between percentages. The minor concepts where significant gender differences in misconception exist are listed in Tables 16 to 29. Critical ratios of the percentage difference between boys and girls in misconceptions were estimated using test of significance between percentages. Tables 16 and 29 to show the results.

Table 16

*Gender Wise Comparison Percentages of Misconception on Minor Concepts in the Area of Matter*

Sl. No	Extent of misconception (%)		Difference	Critical Ratio
	Girls (N=237)	Boys (N=210)		
1	73.58	60.86	12.71	2.77**
2	93.39	88.40	4.99	1.08
3	69.33	70.04	-0.70	0.15
4	50	53.62	-3.62	0.79
5	79.71	61.83	17.88	3.90**

\*\*p<.01

In the concept of *Matter*, boys and girls show difference in the extent of two minor concepts, i.e. girls' possess more misconceptions than boys do in two minor concepts and they are,

- Gases are not matter, because they are invisible, and
- On evaporation water gets converted into oxygen and hydrogen

Table 17

*Gender Wise Comparison Percentages of Misconception on Minor Concepts in the Area of Solar System*

Sl. No	Extent of misconception (%)		Difference	Critical Ratio
	Girls (N=237)	Boys (N=210)		
6	57.54	53.62	3.92	0.85
7	38.67	46.85	-8.18	1.78
8	59.43	61.35	-1.91	0.41
9	58.01	47.34	10.67	2.32*
10	50	31.40	18.59	4.05**
11	30.18	19.80	10.38	2.26*
12	63.67	78.26	-14.58	3.18**

\*\*p<.01; \*p<.05

In the concept of *Solar System*, boys and girls show difference in three minor concepts, i.e., girls' possess more misconceptions than boys do in three minor concepts and they are:

- We see one face of moon from India and the other from America.
- Moon has its own light.
- All stars have the same size.

Boys showed more misconception in only one minor concept i.e.

- Brightness of stars depends only on the distance from Earth

Table 18

*Gender Wise Comparison Percentages of Misconception on Minor Concepts in the Area of Density*

Sl No.	Extent of misconception (%)		Difference	't' - Value
	Girls (N=237)	Boys (N=210)		
13	79.24	55.55	23.68	5.16**
14	14.62	28.50	-13.87	3.02**
15	58.01	59.42	-1.40	0.30
16	85.37	81.64	3.73	0.81
17	66.50	59.90	6.60	1.44
18	50	34.29	15.70	3.42**
19	39.15	24.63	14.51	3.16**

\*\*p<.01

In the concept of *Density*, boys show more misconception than girls do in only one minor concept.

- Low-density substances float in water.

Whereas, girls show more misconceptions in three minor concepts:

- Some substances float in water since they are lighter than water ,
- Due to its heaviness a big cube of ice cannot float.
- Density and volume influence floatation of bodies.

Table 19

*Gender Wise Comparison Percentages of Misconception on Minor Concepts in the Area of Pressure*

Sl No.	Extent of misconception (%)		Difference	't' - Value
	Girls (N=237)	Boys (N=210)		
20	74.05	61.83	12.22	2.66**
21	57.07	39.13	17.94	3.91**

\*\*p<.01

In the concept of *Pressure* girls possess more misconceptions than boys. They are,

- Atmospheric pressure increases with altitude,
- Pressure in sea bed is than that at surface.

Table 20

*Gender Wise Comparison Percentages of Misconception on Minor Concepts in the Area of Velocity*

Sl No.	Extent of misconception (%)		Difference	't' - Value
	Girls (N=237)	Boys (N=210)		
22	52.83	57.00	-4.17	0.91
23	58.49	43.96	14.52	3.16**
24	32.07	31.88	0.19	0.04
25	57.07	54.10	2.96	0.64
26	81.13	73.42	7.70	1.68
27	37.26	50.24	-12.97	2.83**
28	25	37.19	-12.19	2.66**
29	28.77	29.46	-0.69	0.15
30	24.52	42.02	-17.50	3.81**
31	64.62	55.55	9.06	1.97*

\*\*p<.01; \*p<.05

In the concept of **Velocity**, boys show comparatively more misconceptions in minor concepts than girls and they are,

- Units of speed and acceleration are the same,
- Displacement is the total distance travelled by the object,
- To have acceleration the velocity of moving body should be increased.

Whereas, girls show more misconceptions in one minor concept i.e.

- Displacement and distance are always the same.

Table 21

*Gender Wise Comparison Percentages of Misconception in Minor Concepts in the Area of Mass*

Sl No.	Extent of misconception (%)		Difference	't' - Value
	Girls (N=237)	Boys (N=210)		
32	79.24	57.00	22.24	4.85**
33	46.69	43.96	2.73	0.59
34	18.86	16.90	1.95	0.42

\*\*p<.01

In the concept of **Mass**, girls possess more misconceptions than boys and they are,

- When velocity increases the mass of an object will change,
- Mass is equivalent to weight of substance

Table 22

*Gender Wise Comparison Percentages of Misconception on Minor Concepts in the Area of force*

Sl No.	Extent of misconception (%)		Difference	't' - Value
	Girls (N=237)	Boys (N=210)		
35	25	11.11	13.88	3.03**
36	11.32	12.07	-0.75	0.16
37	7.54	4.83	2.71	0.59
38	16.50	19.80	-3.29	0.71
39	66.50	58.93	7.57	1.65

\*\*p<.01

In the major concept of **Force**, only in one minor concept boys and girls show difference in misconceptions, i.e. girls possess more misconception in one minor concept that is ,

- Force can be exerted by human only.

Table 23

*Gender Wise Comparison Percentages of Misconception on Minor Concepts in the Area of Gravity*

Sl No.	Extent of misconception (%)		Difference	't' - Value
	Girls (N=237)	Boys (N=210)		
40	70.75	62.80	7.95	1.73
41	33.49	39.13	-5.63	1.23
42	86.79	82.12	4.66	1.01
43	11.79	16.42	-4.63	1.01
44	71.22	61.83	9.39	2.04*
45	66.98	65.70	1.28	0.27

\*p<.05

In the concept of **Gravity**, boys and girls show difference in misconceptions on one minor concept,

- Gravitational force needs a medium to act.

Table 24

*Gender Wise Comparison Percentages of Misconception in Minor Concepts in the Area of work*

Sl No.	Extent of misconception (%)		Difference	't' - Value
	Girls (N=237)	Boys (N=210)		
46	66.98	65.21	1.76	0.38
47	5.66	8.69	-3.03	0.66
48	55.18	31.40	23.78	5.18**
49	77.83	67.63	10.19	2.22*

\*\*p<.01; \*p<.05

In the concept of **Work**, boys show more misconceptions in two minor concepts than girls and they are,

- Work cannot be done against an applied force.
- Wherever force is in action, work will accompany.

Table 25

*Gender Wise Comparison Percentages of Misconception in Minor Concepts in the Area of Energy*

Sl No.	Extent of misconception (%)		Difference	't' - Value
	Girls (N=237)	Boys (N=210)		
50	9.90	20.28	-10.38	2.26*
51	47.16	53.14	-5.97	1.30
52	62.73	64.73	-1.99	0.43
53	48.58	45.89	2.69	0.58
54	40.09	42.99	-2.90	0.63
55	32.54	30.91	1.62	0.35

\*p<.05

In the major concept of Energy, only in one minor concept, boys and girls show difference in misconceptions i.e., girls possess more misconception in one minor concept that,

- Energy is the capacity to do work.

Table 26

*Gender Wise Comparison Percentages of Misconception in Minor Concepts in the Area of Light*

Sl No.	Extent of misconception (%)		Difference	't' - Value
	Girls (N=237)	Boys (N=210)		
56	59.90	80.19	-20.28	4.42**
57	29.24	53.14	-23.89	5.21**
58	41.50	26.57	14.93	3.25**
59	11.79	13.52	-1.73	0.37
60	44.81	40.09	4.71	1.02
61	73.11	61.83	11.27	2.46*
62	65.09	60.86	4.22	0.92
63	87.73	83.09	4.64	1.01
64	13.20	35.26	-22.05	4.81**

\*\*p<.01; \*p<.05

In the concept of **Light**, boys possess more misconceptions in three minor concepts than girls do and they are,

- The surface that absorbs all colors of visible light appears black, whereas the surface which reflects all colors are seen in white,
- Pencil partially dipped in water appears slightly distorted,
- Light ray travelling through a lens focuses at its centre.

Whereas, girls showed more misconceptions than boys do in two minor concepts i.e.,

- Light rays travel in straight line only,
- Lakes and sea are found in blue color since they reflect sky.

Table 27

*Gender Wise Comparison Percentages of Misconception in Minor Concepts in the Area of sound*

Sl No.	Extent of misconception (%)		Difference	't' - Value
	Girls (N=237)	Boys (N=210)		
65	44.81	26.57	18.24	3.97**
66	28.77	26.57	2.20	0.48
67	37.26	35.26	1.99	0.43
68	74.52	75.84	-1.31	0.28
69	41.50	47.82	-6.31	1.37
70	46.22	38.64	7.57	1.65
71	83.96	84.05	-0.09	0.02
72	47.64	60.86	-13.22	2.88**

\*\*p<.01

In the major concept of *Sound*, boys and girls showed difference in misconceptions only in two minor concepts i.e., girls show more misconception in one minor concept that,

- Sound can do work,
- All sounds are audible to human ear.

Table 28

*Gender Wise Comparison Percentages of Misconception in Minor Concepts in the Area of Magnetism*

Sl No.	Extent of misconception (%)		Difference	't' - Value
	Girls (N=237)	Boys (N=210)		
73	91.98	90.82	1.159	0.25
74	86.32	87.43	-1.11	0.24
75	20.28	24.15	-3.87	0.84

\*\*p<.01

No minor concept in the area of *Magnetism* show significant gender difference in misconceptions.

Table 29

*Gender Wise Comparison Percentages of Misconception in Minor Concepts in the Area of Electricity*

Sl No.	Extent of misconception (%)		Difference	't' - Value
	Girls (N=237)	Boys (N=210)		
76	56.13	42.02	14.10	3.07*
77	89.15	75.36	13.78	3.00*
78	49.16	44.81	4.35	0.66
79	46.22	44	2.22	0.38
80	43	41.50	1.5	0.16

\*\*p<.01

In the major concept of *Electricity*, boys and girls show difference in misconceptions only in two minor concepts i.e. girls possess more misconceptions in two minor concepts that,

- Iron is the best conductor of electricity,
- Pure water is a good conductor of electricity.

The above analysis shows that concept areas of Solar System, Density, Velocity, Mass, Energy and Light are having more number of minor concepts than other areas where significant gender difference exist in misconceptions.

Gender wise comparison of the extent of misconception in selected minor concepts in physics shows that significant gender wise differences exist in 32 minor concepts. 10 minor concepts represented in TCAP shows significantly higher misconceptions among boys than girls do.

Ten minor concepts represented by minor concepts in TCAP shows significantly higher misconceptions among boys than girls did. They are follows.

- i. Light ray travelling through a lens focuses at its centre. (Girls 13.20%; Boys, 35.26%, C.R.= 4.81;  $p < .01$ )
- ii. The surface which absorbs all colours of visible light appears in black where as the (Girls 13.20%; Boys, 35.26%, C.R.= 4.81;  $p < .01$ )
- iii. Surface which reflects all the colors is seen in white (Girls 59.90%; Boys, 80.19%, C.R.= 4.42;  $p < .01$ )
- iv. To have acceleration the velocity of a moving body should be increased (Girls 24.52%; Boys, 42.02 %, C.R.= 3.81;  $p < .01$ )
- v. Brightness of stars depends only on the distance from earth (Girls 63.67%; Boys, 78.26%, C.R.= 3.18;  $p < .01$ )
- vi. Low density substances float in water (Girls 14.62%; Boys, 28.50%, C.R.= 3.02;  $p < .01$ )
- vii. Only a magnet can produce magnetic field (Girls 47.64%; Boys, 60.86%, C.R.= 2.88;  $p < .01$ )
- viii. Units of speed and acceleration are the same (Girls 37.26%; Boys, 50.24%, C.R.= 2.83;  $p < .01$ )
- ix. Displacement is the total distance travelled by the object (Girls 25%; Boys, 37.19%, C.R.= 2.66;  $p < .01$ )
- x. Energy is the capacity to do work (Girls 9.90%; Boys, 20.28%, C.R.= 2.26;  $p < .01$ )

Concepts areas light and velocity have more minor concepts with higher misconception for boys than girls do.

22 minor concepts represented in TCAP show significantly higher misconceptions among girls than boys do. They are as follows.

- i. When velocity increases the mass of substance will change (Girls, 64.62%; Boys, 55.55%, C.R.=1.97;  $p<.01$ )
- ii. Gravity needs a medium to come into action (Girls, 71.22%; Boys, 61.83%; C.R.= 2.04;  $p<.01$ )
- iii. Wherever force is acted work will be done there (Girls, 77.83%; Boys, 67.63 , C.R.= 2.22;  $p<.01$ )
- iv. All stars have the same size (Girls, 30.18%; Boys, 19.80% , C.R.= 2.26;  $p<.01$ )
- v. We see one face of moon from India and the other from America (Girls, 58.01%; Boys, 47.34%, C.R.=.32;  $p<.01$ )
- vi. Lakes and sea are found in blue color since they reflect sky (Girls, 73.11%; Boys, 61.83%, C.R.= 2.46;  $p<.01$ )
- vii. Atmospheric pressure increases with altitude (Girls, 74.05%; Boys, 61.83% , C.R.= 2.66;  $p<.01$ )
- viii. Gases are not matter, because they are invisible (Girls, 73.58%; Boys, 60.86%, C.R.= 2.77;  $p<.01$ )
- ix. Pure water is a good conductor of electricity (Girls, 89.15%; Boys, 75.36% , C.R.= 3.00;  $p<.01$ )
- x. Force is that which can only applied by men (Girls, 25%; Boys, 11.11% , C.R.= 3.03;  $p<.01$ )
- xi. Iron is the best conductor of electricity in nature (Girls, 56.13%; Boys, 42.02% , C.R.= 3.07;  $p<.01$ )
- xii. Density and volume influences floatation of bodies (Girls, 39.15%; Boys, 24.63% , C.R.= 3.16;  $p<.01$ )
- xiii. Displacement and distance are always the same .(Girls, 58.49%; Boys, 43.96%, C.R.= 3.16;  $p<.01$ )
- xiv. Light rays travel in straight line only (Girls, 41.50%; Boys, 26.575, C.R.= 3.25;  $p<.01$ )

- xv. Due to its heaviness a big cube of ice can't float (Girls, 50%; Boys, 34.29%, C.R.= 3.42;  $p < .01$ )
- xvi. On evaporation water gets converted into oxygen and hydrogen (Girls, 79.71%; Boys, 61.83% , C.R.= 3.90;  $p < .01$ )
- xvii. Pressure in sea bed is less than that on surface (Girls, 57.07%; Boys, 39.13% , C.R.= 3.91;  $p < .01$ )
- xviii. Sound can do work (Girls, 44.81%; Boys, 26.57 3.97;  $p < .01$ )
- xix. Moon has its own light (Girls, 50%; Boys, 31.40 C.R.= 3.91 4.05;  $p < .01$ )
- xx. Mass is equivalent to the weight a of substance (Girls, 79.24%; Boys, 57.00% C.R.= 4.85;  $p < .01$ )
- xxi. Some substances floats in water since they are lighter than water (Girls, 79.24%; Boys, 55.55% C.R.= 5.16;  $p < .01$ )
- xxii. Work never takes place against the applied force, (Girls, 55.18%; Boys, 31.40% C.R.= 5.18;  $p < .01$ )

Concepts areas namely Energy, Solar System and Density have more minor concepts with higher misconception for girls than boys do.

### **Comparison of Misconceptions in Major Concepts of Physics by Locale**

Test of significance of difference between percentages is used for the comparison between relevant sub samples on extent of misconception in the major concepts and minor concepts.

The difference between the percentage scores of the comparable groups is tested using two-tailed test of significance of difference between percentages. For the two-tailed test, critical ratio exceeding 2.58 was considered significant at .01 level and critical ratio exceeding 1.96 was treated as significant at .05 level.

Fourteen concepts in physics were ranked according to the extent of misconception in them for rural and urban secondary schools of Kerala. The

ranked extent of incidence of misconception in the major concepts helps to identify the areas of high school physics that are comparatively prone to misconception among rural and urban students.

Table 30

*Concept Wise Percentage of Incidence of Misconception on Selected Concepts among Rural Students*

Sl. No	Concept		Extent of misconceptions in rural students (%)
1	Matter		70.41
13	Magnetism		66.52
14	Electricity		65.49
4	Pressure		61.36
8	Gravity		57.59
3	Density		51.18
2	Solar system		50.11
6	Mass		48.03
10	Energy		47.1
12	Sound		46.84
11	Light		46.51
5	Velocity		45.22
9	Work		39.09
7	Force		20.57

*Note :* The icon colours indicate high rate (red), moderate rate (yellow) and modest rate (green) of misconception

The concepts of Matter showed highest percentage of misconceptions (70.41 percent). The concept of force showed the least misconceptions (20.57 percent). In addition to matter, six other conceptual areas, viz., Magnetism, Electricity, Pressure, Gravity, Density, and Solar System demonstrate high rate (>50 percent) of misconceptions. Six major concepts namely Sound, Light, Mass, Energy, Velocity and Work exhibit moderate rate (between 48 and 39 percent) of misconception. Only one major concept in physics, i.e., Force, has the modest level (>33 percent) of misconception.

Table 31

*Concept Wise Percentage of Incidence of Misconception on Selected Concepts among Urban students*

Sl. No	Concept	Extent of misconceptions in urban students (%)	
1	Matter		69.71
13	Magnetism		67.23
14	Electricity		66.1
3	Density		54.72
12	Sound		54.37
4	Pressure		53.67
8	Gravity		53.38
11	Light		52.22
2	Solar system		49.23
6	Mass		47.74
10	Energy		46.55
5	Velocity		45.51
9	Work		43.38
7	Force		27.23

*Note :* The icon colours indicate high rate (red), moderate rate (yellow) and modest rate (green) of misconception

The concepts of Matter show highest percentage of misconceptions (69.71 percent). The concept of force showed the least (27.23 percent). In addition to Matter, seven other conceptual areas, viz., Magnetism, Electricity, Density, Sound, Pressure and Gravity demonstrate high rate (>50 percent) of misconceptions. Five major concepts namely Solar System, Mass, Energy, Velocity and Work exhibit moderate rate (between 49.23 and 43.38 percent) of misconceptions.

Table 32

*Comparison of Percentage of Misconception on Major Concepts in Physics among Rural and Urban students of Secondary School*

Sl. No	Major Concept	Extent of misconception (%)		Critical Ratio
		Rural (N=315)	Urban (N=152)	
1	Matter	70.41	69.71	0.15
2	Solar system	50.11	49.23	0.19
3	Density	51.18	54.72	0.78
4	Pressure	61.36	53.67	1.69
5	Velocity	45.22	45.51	0.06
6	Mass	48.03	47.74	0.06
7	Force	20.57	27.23	1.46
8	Gravity	57.59	53.38	0.90
9	Work	39.09	43.38	0.94
10	Energy	47.10	46.55	0.12
11	Light	46.51	52.22	1.26
12	Sound	46.84	54.37	1.6
13	Magnetism	66.52	67.23	0.15
14	Electricity	65.49	66.10	0.13

\*\*p<.01; \*p<.05

Table 32 shows that none of the critical ratios obtained for the test of significance of difference between percentages of misconception in major concepts among rural and urban students are significant. There is no significant difference in percentage of misconception among rural and urban students in the fourteen major concepts viz., Matter, Solar System, Density, Pressure, Velocity, Mass, Force, Gravity, Work, Energy, Light, Sound, Magnetism and Electricity (p<.05). Figure 5 shows a comparison of extent of misconception in major concepts of physics by locale.

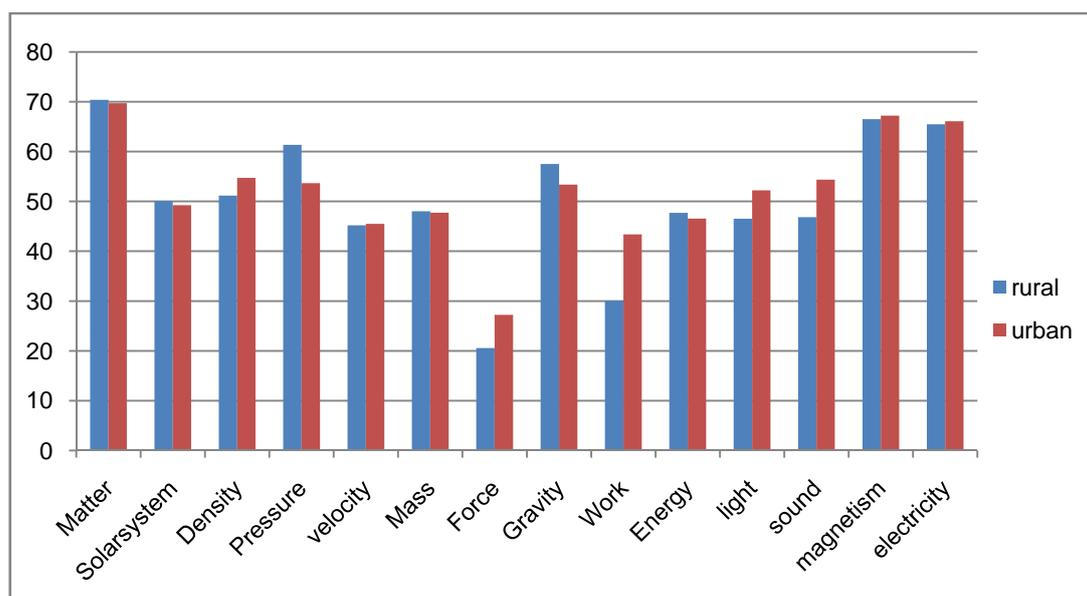

Figure 5. Cluster bar diagram of extent of misconception in major concepts in physics among secondary school students by locale

### Locale Wise Comparison of Extent of Misconceptions in Minor Concepts in Physics

Though no major concepts demonstrate locale difference in misconception in physics, locale wise comparisons of extent of misconceptions on minor concepts in physics are done with the assumption that a locale wise difference in misconception on minor concepts may be neutralized if misconception regarding a few have different extents in one locale compared to the other concepts. Concepts causing significantly different misconception rates among rural and urban students are identified by estimating the critical ratio of significance of difference between percentages. The minor concepts where significant gender differences in misconception exist are listed in Tables 33 to 46. Critical ratios of the percentage difference between rural and urban students in misconceptions are estimated using test of significance between percentages. Tables 33 to 46 show the results.

Table 33

*Locale Wise Comparison of Percentages of Misconception on Minor Concepts in the Area of Matter*

Sl. No	Extent of misconception (%)		Difference	Critical Ratio
	Rural (N=315)	Urban (N=152)		
1	60.33	76.83	-16.50	3.55**
2	97.10	82.4	14.62	3.15**
3	71.07	67.79	3.27	0.70
4	46.69	58.75	-12.06	2.59**
5	76.85	62.71	14.14	3.04**

\*\*p<.01

In the concept of **Matter**, rural and urban students show difference in the extent of four minor concepts, i.e., urban students showed more misconceptions in two minor concepts, whereas the rural students show weakness in the other two ; they are respectively:

- Gases are not matter since they are invisible,
- All metals exist in solid form,
- Gases are massless and on evaporation water gets converted into oxygen and hydrogen.

Table 34

*Locale Wise Comparison of Percentages of Misconception on Minor Concepts in the Area of Solar System*

Sl. No	Extent of misconception (%)		Difference	Critical Ratio
	Rural (N=315)	Urban (N=152)		
6	59.91	49.71	10.19	2.19**
7	30.99	58.75	-27.76	5.98**
8	67.76	50.28	17.48	3.76**
9	51.65	54.23	-2.58	0.55
10	39.66	42.37	-2.70	0.58
11	26.03	23.72	2.30	0.49
12	74.79	65.53	9.25	1.99

\*\*p<.01; \*p<.05

In the concept of *Solar System*, rural and urban students show difference in three minor concepts, i.e., rural students possess more misconceptions than urban students did in two out of three minor concepts and they are:

- Energy of sun never ceases,
- Sun is not a star,
- The same side of moon is always seen from earth.

Table 35

*Locale Wise Comparison of Percentages of Misconception on Minor Concepts in the Area of Density*

Sl No.	Extent of misconception (%)		Difference	't' – Value
	Rural (N=315)	Urban (N=152)		
13	65.28	70.62	-5.33	1.14
14	21.90	20.90	0.99	0.21
15	54.95	63.84	-8.88	1.91
16	79.75	88.70	-8.94	1.92
17	61.98	64.97	-2.98	0.64
18	43.38	40.67	2.71	0.58
19	30.99	33.33	-2.34	0.50

\*\*p<.01

In the concept of *Density*, rural and urban students do not show significant difference in conceiving the ideas. They have almost similar sense of perception in this area.

Table 36

*Locale Wise Comparison Percentages of Misconception on Minor Concepts in the Area of Pressure*

Sl No.	Extent of misconception (%)		Difference	't' – Value
	Rural (N=315)	Urban (N=152)		
20	69.42	66.10	3.31	0.71
21	53.30	41.24	12.06	2.59**

\*\*p<.01

In the concept of *Pressure* comparatively rural pupil posses more misconceptions than urban students in one of the minor concepts and no significant difference in the other. The minor idea where difference exists is

- Pressure in sea bed is less than that at surface.

Table 37

*Locale Wise Comparison Percentages of Misconception on Minor Concepts in the Area of Velocity*

Sl No.	Extent of misconception (%)		Difference	't' – Value
	Rural (N=315)	Urban (N=152)		
22	51.23	59.88	-8.64	1.86
23	47.93	55.93	-7.99	1.72
24	30.57	33.89	-3.31	0.71
25	55.37	55.93	-0.56	0.12
26	78.09	76.27	1.82	0.39
27	40.90	47.45	-6.54	1.41
28	40.90	17.51	23.39	5.04**
29	27.68	31.07	-3.38	0.73
30	34.29	31.63	2.65	0.57
31	59.91	60.45	-0.53	0.11

\*\*p<.01; \*p<.05

In the concept of Velocity, rural and urban students show significant difference in only in one case out of nine and it is,

- Displacement is the total distance travelled by an object.

Rural students show more misconception than urban on this concept

Table 38

*Locale Wise Comparison Percentages of Misconception on Minor Concepts in the Area of Mass*

Sl No.	Extent of misconception (%)		Difference	't' – Value
	Rural (N=315)	Urban (N=152)		
32	65.28	72.31	-7.02	1.51
33	45.86	44.63	1.23	0.26
34	21.07	13.55	7.51	1.61

\*\*p<.01

In the concept of **Mass**, rural and urban students do not show significant difference in conceiving the ideas. They have almost similar sense of perception in this area.

Table 39

*Locale Wise Comparison Percentages of Misconception on Minor Concepts in the Area of Force*

Sl No.	Extent of misconception (%)		Difference	't' – Value
	Rural (N=315)	Urban (N=152)		
35	18.18	18.07	0.10	0.02
36	9.50	14.68	-5.18	1.11
37	6.61	5.64	0.96	0.20
38	14.46	23.16	-8.70	1.87
39	54.13	74.57	-20.44	4.40**

\*\*p<.01

In the major concept of **Force**, rural and urban students showed difference in misconceptions only in one minor concept , i.e. urban students show more misconception that is ,

- A body is at rest means no force is acting upon it.

Table 40

*Gender Wise Comparison Percentages of Misconception in Minor Concepts in the Area of Gravity*

Sl No.	Extent of misconception (%)		Difference	‘t’ – Value
	Rural (N=315)	Urban (N=152)		
40	64.87	69.49	-4.61	0.99
41	50.41	16.94	33.46	7.21**
42	83.47	85.87	-2.40	0.51
43	11.15	18.07	-6.92	1.49
44	64.87	68.92	-4.05	0.87
45	70.24	61.01	9.23	1.98*

\*p<.05

In the concept of Gravity rural and urban students show difference in misconceptions for two minor concepts, i.e., rural students show more difference in two minor concepts

- Acceleration due to gravity is similar in all countries over the world.
- Gravitational force does not act without air.

Table 41

*Locale Wise Comparison Percentages of Misconception on Minor Concepts in the Area of Work*

Sl No.	Extent of misconception (%)		Difference	't' – Value
	Rural (N=315)	Urban (N=152)		
46	61.98	71.75	-9.76	2.10**
47	7.85	6.21	1.63	0.35
48	42.97	44.06	-1.09	0.23
49	66.11	81.92	-15.80	3.40**

\*\*p<.01; \*p<.05

In the concept of **Work**, urban students show comparatively more misconceptions in two minor concepts than rural students and they are,

- Work and labour are the same.
- Wherever force is acted work is done there.

Table 42

*Locale Wise Comparison Percentages of Misconception on Minor Concepts in the Area of Energy*

Sl No.	Extent of misconception (%)		Difference	't' – Value
	Rural (N=315)	Urban (N=152)		
50	16.52	12.99	3.53	0.76
51	52.89	46.32	6.56	1.41
52	61.98	66.10	-4.11	0.88
53	52.06	40.67	11.38	2.45*
54	38.01	46.32	-8.31	1.79
55	30.57	33.33	-2.75	0.59

\*p<.05

In the major concept of **Energy** , rural and urban students show difference in misconceptions only in one minor concept i.e., rural students show more misconception in one minor concept that is,

- A body at rest does not possess potential energy.

Table 43

*Locale Wise Comparison Percentages of Misconception on Minor Concepts in the area of Light*

Sl No.	Extent of misconception (%)		Difference	't' – Value
	Rural (N=315)	Urban (N=152)		
56	68.59	71.75	-3.15	0.68
57	42.56	38.98	3.57	0.77
58	23.55	48.58	-25.03	5.39**
59	14.04	10.73	3.31	0.71
60	44.21	40.11	4.10	0.88
61	61.98	75.14	-13.15	2.83**
62	61.57	64.97	-3.40	0.73
63	86.36	84.18	2.18	0.47
64	15.70	35.59	-19.89	4.28**

\*\*p<.01; \*p<.05

In the major concept of **Light**, rural and urban students show difference in three minor concepts where urban students are having more misconceptions than rural students and they are

- Light travels in straight line,
- Pools and sea are seen in blue colour due to the reflection of sky,
- Light rays are focused at the focus of optical lens .

Table 44

*Locale Wise Comparison Percentages of Misconception on Minor Concepts in the Area of Sound*

Sl No.	Extent of misconception (%)		Difference	't' – Value
	Rural (N=315)	Urban (N=152)		
65	35.95	35.59	0.357	0.07
66	29.75	24.85	4.89	1.05
67	33.88	39.54	-5.6	1.22
68	76.44	73.44	2.99	0.64
69	39.66	51.41	-11.74	2.53*
70	34.29	53.67	-19.37	4.17**
71	81.40	87.57	-6.16	1.32
72	43.38	68.92	-25.53	5.50**

\*\*p<.01; \*p<.05

In the concept of **Sound**, urban pupils possess more misconceptions than rural ones in three minor concepts viz.,

- To travel light does not need a medium,
- All sounds are audible,
- No sound is inaudible to human ear.

Table 45

*Gender Wise Comparison Percentages of Misconception on Minor Concepts in the Area of Magnetism*

Sl No.	Extent of misconception (%)		Difference	't' – Value
	Rural (N=315)	Urban (N=152)		
73	88.84	94.91	-6.07	1.30
74	86.36	87.57	-1.20	0.26
75	24.38	19.20	5.17	1.11

No minor concept in the area of *Magnetism* shows significant locale difference in misconceptions.

Table 46

*Gender Wise Comparison Percentages of Misconception on Minor Concepts in the Area of Electricity*

Sl No.	Extent of misconception (%)		Difference	't' – Value
	Rural (N=315)	Urban (N=152)		
76	47.93	50.84	-2.91	.62
77	83.05	81.35	1.70	0.36
78	50.84	47.93	-2.91	0.61
79	48.58	43.38	5.2	1.30
80	45.86	44.63	1.23	0.26

No minor concepts in the area of electricity show significant locale difference in misconceptions.

The above analysis shows that concept areas of Density, Mass, Electricity, Energy and Magnetism do not possess significant difference in conceiving minor concepts than other pertinent areas. Upon gender wise comparison, it is evident that locality does not have much influence in differentiating students with the measure of misconception.

Locale wise comparison of extent of misconception in selected minor concepts in physics shows that significant locale wise differences exist in 21 minor concepts. Twelve minor concepts represented in TCAP show significantly higher misconceptions among urban students than rural students do.

Nine minor concepts represented by minor concepts in TCAP show significantly higher misconceptions among rural students than urban students do. They are follows.

Twelve minor concepts represented by minor concepts in TCAP shows significantly higher misconceptions among urban than rural did. They are follows.

- i. Gases are not matter since they are invisible. (rural, 60.33%; urban, 76.83%, C.R.= 3.55;  $p < .01$ )
- ii. All metals exist in solid form. (rural, 46.69%; urban, 58.75%, C.R.= 2.59;  $p < .01$ )
- iii. Sun is not a star. (rural, 30.99%; urban, 58.75%, C.R.= 5.98;  $p < .01$ )
- iv. If an object is at rest there is no force acting on it. (rural, 54.13%; urban, 74.57%, C.R.= 4.40;  $p < .01$ )
- v. Work and labour are the same. (rural, 61.98%; urban, 71.75%, C.R.= 2.10;  $p < .01$ )
- vi. Wherever force is acting work will be done there. (rural, 66.11%; urban, 81.92%, C.R.= 3.40;  $p < .01$ )
- vii. Light rays travel in straight line only. (rural, 23.55%; urban, 48.58%, C.R.= 5.39;  $p < .01$ )
- viii. Lakes and sea are found in blue color since they reflects sky. (rural, 61.98%; urban, 75.14%, C.R.= 2.83;  $p < .01$ )
- ix. Light ray travelling through a lens focuses at its centre. (rural, 15.70%; urban, 35.59%, C.R.= 4.28;  $p < .01$ )
- x. Sound needs no medium to travel. (rural, 39.66%; urban, 51.41%, C.R.= 2.53;  $p < .01$ )
- xi. All kinds of sounds make the sense of sound in human brain. (rural, 34.29%; urban, 53.67%, C.R.= 4.17;  $p < .01$ )
- xii. All sounds are audible to human ear. (rural, 43.38%; urban, 68.92%, C.R.= 5.50;  $p < .01$ )

Nine minor concepts represented by minor concepts in TCAP shows significantly higher misconceptions among rural than urban do. They are follows.

- i. Gases are mass less. (rural, 97.10%; urban, 82.4%, C.R.= 3.15;  $p < .01$ )
- ii. On evaporation, water is converted into oxygen and hydrogen. (rural, 76.85%; urban, 62.71%, C.R.= 3.04;  $p < .01$ )

- iii. Energy of Sun never ceases. (rural 59.91%; urban, 49.71%, C.R.= 2.19;  $p < .01$ )
- iv. The same side of moon is always seen from Earth. (rural 67.76%; urban, 50.28 %, C.R.= 3.76;  $p < .01$ )
- v. Pressure in seabed is less than that on surface. (rural 53.30%; urban, 41.24 %, C.R.= 2.59;  $p < .01$ )
- vi. Displacement is the total distance travelled by an object. (rural 40.90%; urban 17.51 %, C.R.= 5.04;  $p < .01$ )
- vii. Acceleration due to gravity is the same everywhere. (rural 50.41%; urban 16.94%, C.R.= 7.21;  $p < .01$ )
- viii. Without air, (medium) gravity cannot act through. (rural, 70.24%; urban, 61.01%, C.R.= 1.98;  $p < .01$ )
- ix. Stationary objects do not have potential energy. (rural 52.06%; urban 40.67%, C.R.= 2.45;  $p < .01$ )

## **Discussion**

The survey was conducted to find out the extent of misconception. Percentage analysis of preliminary survey is done with locale and gender as discriminating factors. From the concept wise percentage analysis of fourteen concepts, it is found that major concept of Matter shows maximum percentage of misconception and that of Force shows the least. The rest of the twelve concepts show above forty percentage in misconceptions, where six concept show above fifty percentages of misconceptions. Minor concept of Magnetism and Matter, show high misconceptions i.e., above ninety percentage. Forty-five minor concepts show above fifty percentage of misconceptions and least percentage of misconception is shown by the minor concept of Force i.e., six percentage. From

the misconceptions percentage of boys and girls, it is found that three major concepts viz., Pressure, Mass and Electricity show significant difference in misconceptions. Rest of the twelve concepts areas shows no difference. Thirty-two minor concepts show significant difference among boys and girls. In locale wise comparison, girls and boys shows no significant difference in major concepts but twenty minor concepts show difference which is less than gender wise comparison of minor concepts. In the analysis of rural girls and urban girls only one major concept, i.e. Pressure show difference whereas in rural boys and urban boys only major concept of Sound shows significant difference in concept attainment.

Extent of misconceptions in urban boys and girls only the major concept of Velocity shows difference whereas in rural boys and girls four major concepts show significant difference, they are Density, Pressure, Mass and Electricity.

### **Effectiveness of Selected Experimental Instructional Strategies in Remediation of Misconceptions in Physics**

Effectiveness of four select remedial instructional strategies to correct misconceptions in various areas of physics was studied using pretest posttest matched control group design. The match between the experimental and control groups on concept attainment in, Sound, Pressure, Motion and Electricity, Magnetism, Plus Light Force, prior to participative approach, concept map, concept change cum concept map and conceptual change strategies respectively were studied using paired t test. The comparison of concept attainment scores in sound, pressure, motion and electricity, magnetism plus light and force, after imparting remedial instruction through participative approach, concept map, concept change cum concept map and conceptual change respectively were again studied using paired t test.

**Match between the Experimental and Control Groups on Concept Attainment in Relevant Areas of Physics Prior To Remedial Instruction**

Two matched groups of eight standard students were used in the experimental phase of this study. For this, administration of the pretest of conceptual attainment in physics was done to three intact groups of eighth standard students. One group was randomly assigned as experimental group. The students in the other two intact groups were chosen for control group by applying the criteria of matching on the pretest scores of an individual of the same gender in the experimental group. Thus, forty-seven students matching on pretest scores of conceptual understanding in physics and gender were obtained in the experimental and control groups. However, two individuals in the control group had one score each above their counterparts in the experimental group. Thus, the two groups were matched based on gender and score on conceptual understanding in physics prior to intervention. The correlation between the two groups on pretest scores on conceptual understanding in physics is 0.99 (N=47,  $p < .01$ ). Table 47 shows that the experimental and comparison groups are nearly perfect matching in academic aspects, and that there is no significant difference between the experimental, and control groups on pretest scores of conceptual attainment in physics.

Table 47

*Test of Significance of Difference between Mean Pretest Scores of Experimental and Control Groups on Concept Attainment in Physics*

Experimental group			Control group			t	r
M	SD	N	M	SD	N		
16.47	2.50	47	16.47	2.45	47	0	.99**

\*\* $p < .01$

Paired-samples t-test was conducted to compare concept attainment in physics between experimental and control groups prior to the administration of remedial instruction (Table 47). There was no significant difference in the scores concept attainment in physics of the experimental ( $M=16.46$ ,  $SD =2.50$ ) and control ( $M =16.46$ ,  $SD = 2.44$ ) groups;  $t(95) = 0$ ,  $p > .05$ . These results suggest that experimental and control groups showed no significant difference on the concept attainment in physics before the remedial intervention is used.

Figure 6 demonstrate that the two groups are nearly identical with respect to concept attainment in physics.

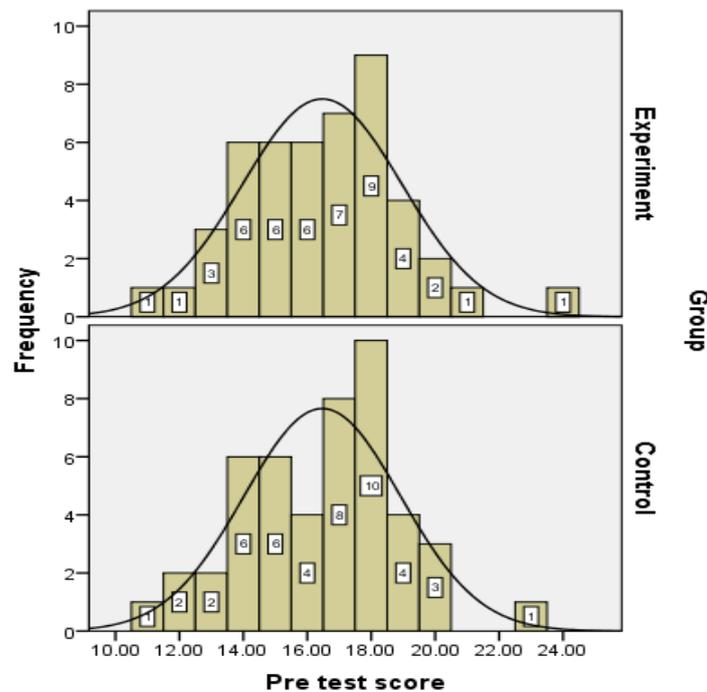

Figure 6. Histogram with normal curves best fit on them of pretest scores of concept attainment in physics of experimental and control groups

Figure 6 shows the frequency distribution of pretest scores of concept attainment in physics of experimental and control groups. It shows that the least scores on the groups are parallel; the highest score in control group is 23, while that in experimental group is 24. The modes on both distributions are 10.

Since the study compares the effects of different strategies for remedying misconceptions in various major conceptual areas in physics of standard eight students, the pretest scores of experimental and control groups on concept attainment in these areas were explored. Four different strategies were used to eradicate misconceptions in students. They are conceptual change strategy, conceptual change along with concept map, concept map and participative approach. Pretest scores on the concepts on which these four strategies were applied were studied using paired t test of comparison between means. Results are presented in Table 48.

Table 48

*Indices of Pretest Scores of Misconceptions in Select Areas of Physics of Standard Eight Students Prior to Remediation Programmes*

Strategy	Groups compared	M	Median	Mode	SD	Skewness	Kurtosis
Conceptual change	Control	10.55	10	10	1.82	-0.23	0.80
	Experimental	10.26	10	10	2.41	0.59	1.19
Concept map	Control	2.43	2	2	1.04	0.27	-0.55
	Experimental	2.49	2	2	1.00	-0.04	-1.01
Conceptual change & concept map	Control	1.79	2	1	0.88	0.05	0.35
	Experimental	1.79	2	1	0.88	0.44	-0.62
Participative approach	Control	1.70	2	2	0.91	0.09	-0.09
	Experimental	1.94	2	2	0.82	-0.13	-0.92

Table 48 shows that prior to conceptual change strategy, mean scores of attainment of concepts in the area of pressure in Experimental (M =10.26) and control groups (M= 10.55) were nearly equal. Likewise, median scores of attainment of concepts in the area of pressure of both experimental and control groups fall on 10. Mode of scores of attainment of concepts in the area of

pressure of both experimental and control groups are 10. These, along with Figure 7d demonstrates that prior to conceptual change strategy the experimental and control groups had nearly identical attainment of concepts in the area of pressure.

Table 48 shows that prior to conceptual change cum concept map strategy, mean scores of attainment of concepts in the areas of force, density, magnetism, light, and electricity in experimental ( $M = 1.79$ ) and control groups ( $M = 1.79$ ) were equal. Likewise, median scores of attainment of concepts in the areas of force, density, magnetism, light, and electricity of both experimental and control groups are two. Mode of scores of attainment of concepts in the areas of force, density, magnetism, light, and electricity of both experimental and control groups are one. These along with Figure 7c demonstrates that prior to conceptual change strategy along with concept map the experimental and control groups had nearly identical attainment of concepts in the areas of force, density, magnetism, light, and electricity.

Table 48 shows that prior to concept map strategy mean scores of attainment of concepts in the concept area motion in experimental ( $M = 2.49$ ) and control groups ( $M = 2.43$ ) were nearly equal. Likewise, median scores of attainment of concepts in the area motion of both experimental and control groups fall on 2. Mode of scores of attainment of concepts in the area motion of both experimental and control groups is 2. These along with Figure 7b demonstrates that prior to concept map strategy the experimental and control groups had nearly identical attainment of concepts in the area motion.

Table 48 shows that prior to participative approach strategy mean scores of attainment of concepts in the area of sound in Experimental ( $M = 1.94$ ) and control groups ( $M = 1.7$ ) were nearly equal. Likewise, median scores of attainment of concepts in the area of sound of both experimental and control groups fall on 2. Mode of scores of attainment of concepts in the area of sound of

both experimental and control groups is 2. These along with Figure 7a demonstrates that prior to participative approach strategy the experimental and control groups had nearly identical attainment of concepts in the area of sound.

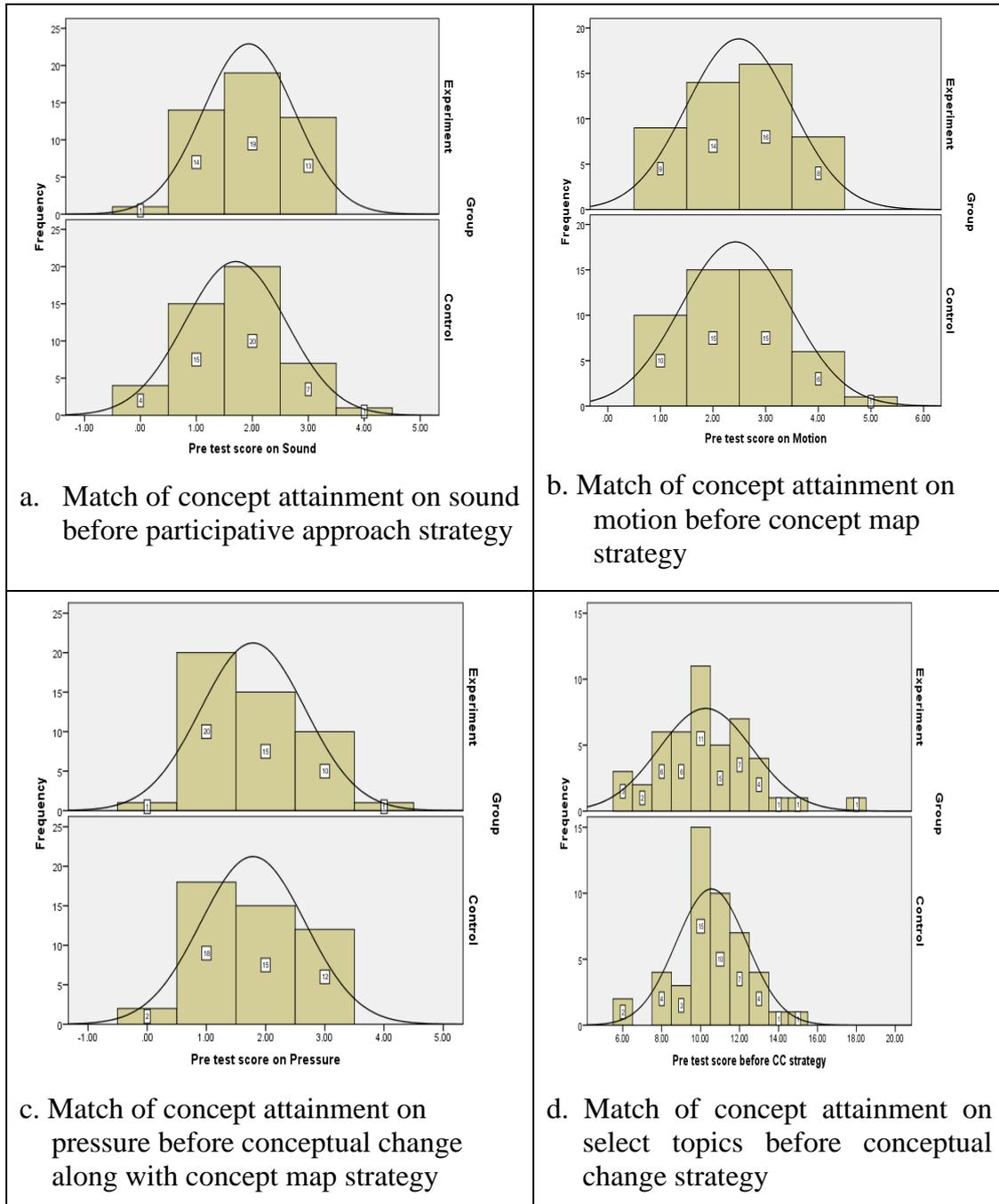

Figure 7. Histograms with normal curve which best fit on them of the distribution of the pretest scores of four areas of standard eight physics on which the effectiveness of remediation of misconception were studied, (showing the match between experimental and control groups on attainment of concepts in these areas prior to intervention)

Four different strategies were used to eradicate misconceptions in students. They are conceptual change strategy, conceptual change along with concept map, concept map and participative approach. Pretest scores on the concepts on which these four strategies were applied were studied using paired t test of comparison between means. Results are presented in Table 49 .

Table 49

*Comparisons in Concept Attainment in Select Areas of Physics between Experimental and Control Prior to the Application of Remedial Strategies*

Remedial Strategy	Experimental			Control group			t value	r
	M	SD	N	M	SD	N		
Participative approach	1.94	0.82	47	1.70	0.91	47	1.31	0.21
Concept map	2.49	1.00	47	2.43	1.70	47	0.30	0.19
Conceptual change	10.26	2.41	47	10.55	1.82	47	-0.68	0.19
Conceptual change & concept map	1.79	0.88	47	1.79	0.88	47	0	0.66

Paired-samples t-test was conducted to compare concept attainment in sound between experimental and control groups prior to the administration of participative approach (Table 49). There was no significant difference in the scores concept attainment in sound of the experimental ( $M=1.94$ ,  $SD =.82$ ) and control ( $M =1.70$ ,  $SD = .91$ ) groups;  $t(95) = 1.31$ ,  $p > .05$ . These results suggest that experimental and control groups were not significantly different on the concept attainment in sound before the remedial intervention using participative approach.

Paired-samples t-test was conducted to compare concept attainment in motion between experimental and control groups prior to the administration of concept map strategy (Table 49). There was no significant difference in the scores concept attainment in motion of the experimental ( $M=2.49$ ,  $SD =.1$ ) and control ( $M = 2.43$ ,  $SD = 1.$ ) groups;  $t(95) = 0.30$ ,  $p > .05$ . These results suggest

that experimental and control groups were not significantly different on the concept attainment in motion before the remedial intervention using concept map.

Paired-samples t-test was conducted to compare concept attainment in areas of force, density, magnetism, light, and electricity between experimental and control groups prior to the administration of conceptual change cum concept map strategy (Table 49). There was no significant difference in the scores concept attainment in areas of force, density, magnetism, light, and electricity of the experimental ( $M = 1.79$ ,  $SD = 0.88$ ) and control ( $M = 1.79$ ,  $SD = 1.82$ ) groups;  $t(95) = -0.68$ ,  $p > .05$ . These results suggest that experimental and control groups were not significantly different on the concept attainment in areas of force, density, magnetism, light, and electricity before the remedial intervention using conceptual change cum concept map strategy.

Paired-samples t-test was conducted to compare concept attainment in pressure between experimental and control groups prior to the administration of conceptual change and concept map strategy. (Table 49). There was no significant difference in the scores concept attainment in sound of the experimental ( $M = 10.26$ ,  $SD = 2.41$ ) and control ( $M = 10.55$ ,  $SD = .88$ ) groups;  $t(95) = 0$ ,  $p > .05$ . These results suggest that experimental and control groups were not significantly different on the concept attainment in pressure before the remedial intervention using conceptual change and concept map strategy.

## **Discussion**

Paired-samples t-test along with the correlation between the pretest scores have revealed the identical nature of the experimental and control groups on concept attainment in physics before the remedial instruction programme. Paired-samples t-tests have also revealed the match between the experimental and control groups on concept attainment in, sound, pressure, motion and electricity, magnetism, plus light, force, prior to participative approach, concept map, concept change cum concept map and conceptual change respectively. The

experimental and control group were not significantly different on concept attainment in the select areas of physics before the experimental intervention employing the remedial instruction programmes using participative approach, concept map, concept change cum concept map and conceptual change.

### **Effect of Selected Experimental Instructional Strategies in Remediation of Misconceptions in Physics**

Effectiveness of four select remedial instructional strategies to correct misconceptions in various areas of physics was studied using pretest posttest matched control group design. Paired-samples t-test between the posttest scores of the experimental and control groups on concept attainment in physics after the remedial instruction programme was done. The comparison between the experimental and control groups on concept attainment in, sound, pressure, motion and electricity, magnetism, plus light, force, after the participative approach, concept map, concept change cum concept map and conceptual change respectively were also done using paired t test. After the administration of intervention to treatment group and no treatment to control group, posttest were conducted. Results are in Table 50.

Table 50

*Test of Significance of Difference between Mean Posttest Scores of Experimental and Control Group*

Experimental group			Control group			t value	r	Cohen's d
M	SD	N	M	SD	N			
29.28	2.78	47	15.51	2.40	47	26.21	.037	5.73

Table 50 reveals that the experimental group ( $M=29.27$ ,  $SD =2.77$ ) shows significantly higher concept attainment in selected physics concepts compared to control group ( $M =15.5106$ ,  $SD = 2.40$ ),  $t(95) = 26.20$ ,  $p < .01$ .

The comparison of mean posttest scores shows significant difference between the groups, it can be said that the intervention program for the eradication of misconceptions in physics is fruitful. The coefficient of correlation between posttest scores of two groups is .037 i.e., the scores are feebly correlated. The intervention programmes made marked difference in the scores of treatment group. Hence the correlation dropped. Effect size came to a value  $d=5.73$  implying large Cohen’s effect size.

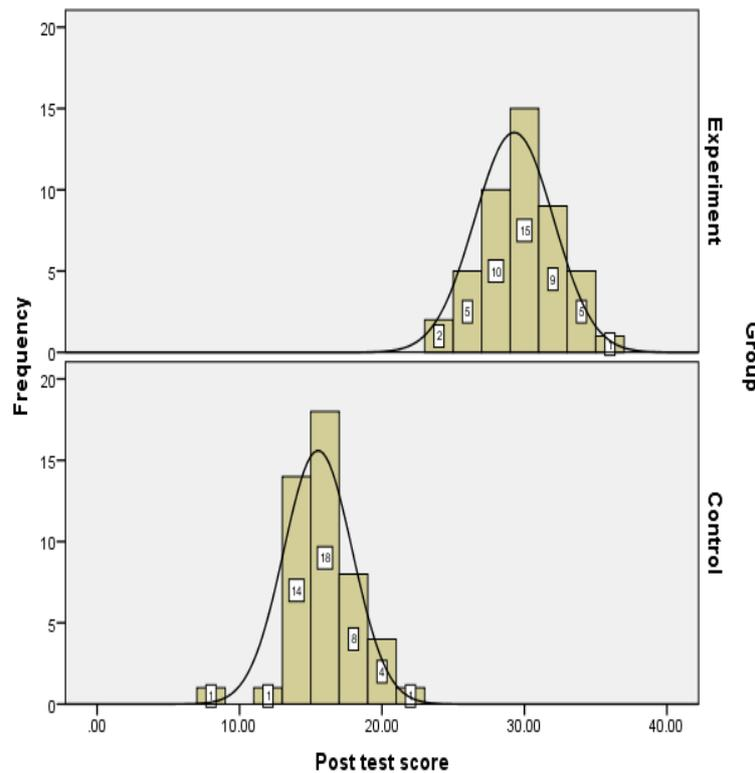

*Figure 8.* Histogram with normal curves best fit on them of posttest scores of concept attainment in physics of experimental and control groups

Four different strategies to eradicate misconceptions in students such as conceptual change strategy, conceptual change along with concept map, concept map and participative approach are administered in experimental group. After administering posttest to the experimental group, the preliminary statistics are analyzed and shown in the Table 51. Experimental and control groups were studied on concept attainment in, sound, pressure, motion and electricity, magnetism, plus light, force, after the participative approach, concept map,

concept change cum concept map and conceptual change respectively were also done using paired t test. Results are shown in Table 51.

Table 51

*Indices of Posttest Scores of Misconceptions in Select Areas of Physics of Standard Eight Students after execution of Remediation Programmes*

Strategy used	Groups compared	Mean	Median	Mode	SD	Skewness	Kurtosis
Conceptual change	Control	11.08	10	10	1.81	-0.23	0.80
	Experimental	18.53	19	18	1.91	-0.52	1.05
Conceptual change & concept map	Control	1.78	1	1	.98	0.41	-0.30
	Experimental	3.09	3	3	.65	-0.09	-0.56
Concept map	Control	2.73	2	2	1.19	0.09	-0.34
	Experimental	4.60	5	5	0.85	0.35	0.68
Participative approach	control	1.99	2	2	0.85	0.08	0.32
	Experimental	3.29	3	3	0.72	-0.32	-0.524

Table 51 shows that after administering conceptual change strategy to experimental group, mean scores of attainment of concepts in the area of pressure in Experimental (M =18.53) and control groups (M= 11.08) were different. Likewise, median scores of attainment of concepts in the area of pressure of experimental and control groups are 19 and 10 respectively. Mode of scores of attainment of concepts in the area of pressure of both experimental and control groups are 18 and 10. These along with figure 9d demonstrates that after the administration of conceptual change strategy the experimental and control groups had different levels of attainment of concepts in the area of pressure.

Table 51 shows that scores after the administration of conceptual change along with concept map strategy to the experimental group, mean scores of attainment of concepts in Electricity, Magnetism, Light, and Force in

Experimental ( $M = 3.09$ ) and control groups ( $M = 1.78$ ) were different. Likewise, median scores of attainment of concepts in electricity, magnetism, plus light, and force of both experimental and control groups are 3 and 1 respectively. Mode of scores of attainment of concepts in electricity, magnetism, plus light, and force of both experimental and control groups are again 3 and 1. These along with Figure 9c demonstrates that after the administration of conceptual change strategy along with concept map the experimental and control groups had different levels attainment of concepts in electricity, magnetism, plus light, and force.

Table 51 shows the scores after the administration of concept map strategy the experimental and control groups, mean scores of attainment of concepts in the area of motion in Experimental ( $M = 4.60$ ) and control groups ( $M = 2.73$ ) were different. Likewise, median and mode scores of attainment of concepts in the area of motion of both experimental and control groups are 5 and 2 respectively. These along with Figure 9b demonstrates that the experimental and control groups after the administration of concept map strategy had different levels of attainment of concepts in the area of motion.

Table 51 shows the scores after the administration of participative approach in the experimental and control groups, mean scores of attainment of concepts in the area of sound in Experimental ( $M = 3.29$ ) and control groups ( $M = 1.99$ ) were different. Likewise, median and mode scores of attainment of concepts in the area of sound of both experimental and control groups are 3 and 2 respectively. These along with Figure 9a demonstrates that after the administration of participative approach the experimental and control groups had different levels of attainment of concepts in the area of sound.

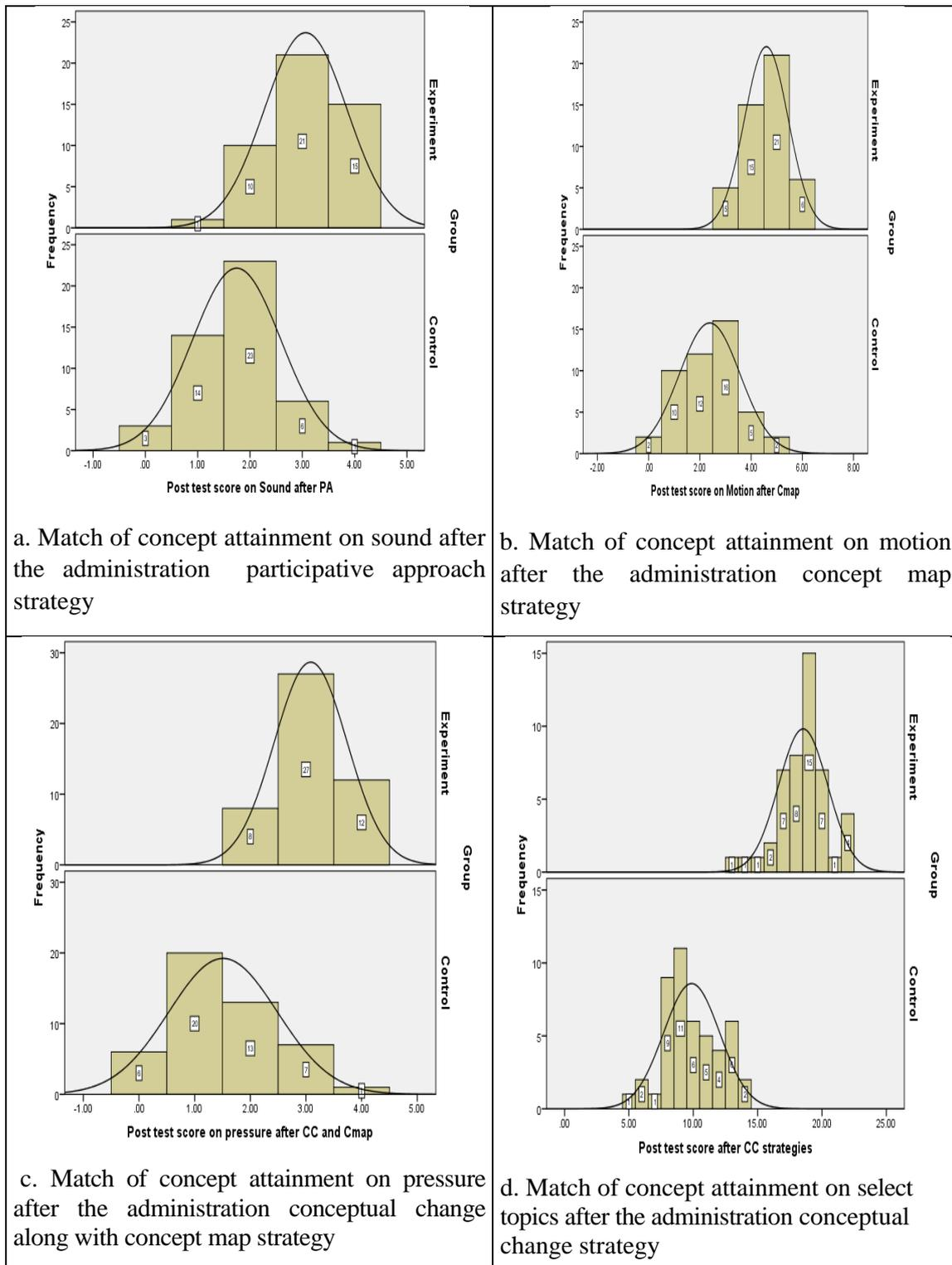

Figure 9. Histograms with normal curve which best fit on them of the distribution of the posttest scores of four areas of standard eight physics on which the effectiveness of remediation of misconception were studied, (showing difference between experimental and control groups on attainment of concepts in these areas after intervention)

Table 52

*Comparison of Concept Attainment between Experimental and Control Groups After the Administration of Instructional Programmes on Remediation of the Misconcepts*

Strategy used	Experimental group			Control group			Critical ratio	r	Cohen's d
	M	SD	N	M	SD	N			
Participative approach	3.06	.79	47	1.74	.85	47	7.8	-.04	2.24
Concept map	4.60	.85	47	2.38	1.19	47	10.37	-.12	1.86
Conceptual change	18.53	1.99	47	9.87	2.18	47	20.46	.65	3.96
Conceptual change & concept map	3.1	.65	47	1.5	.95	47	9.19	0	1.61

Table 52 reveals that concept attainment in sound after remedial instruction through participative approach ( $M=3.06$ ,  $SD =.79$ ) is significantly higher compared to that of the control group ( $M =1.74$ ,  $SD = .84$ ),  $t(95) = 7.81$ ,  $p < .05$ . It can be said that the intervention programme for the eradication of misconceptions in sound through participative approach is effective. The intervention programme made marked difference in the scores of treatment group. This is evident from Cohen's  $d = 2.24$  implying large effect size. Participative approach significantly and strongly remediates misconcepts in the conceptual area of sound in secondary school students, in comparison to no treatment control group, ( $p<.01$ ).

Table 52 reveals that concept attainment in motion concepts after remedial instruction through concept map approach ( $M=4.59$ ,  $SD =.85$ ) shows significantly higher compared to that of control group ( $M =2.38$ ,  $SD = 1.18$ ),  $t(95) = 10.31$ ,  $p < .05$ . It can be said that the intervention program for the eradication of misconceptions in motion through concept map approach is effective. The intervention programme made marked difference in the scores of

treatment group. This is evident from Cohen's  $d = 1.86$  implying large effect size. Concept map strategy significantly and strongly remediates misconceptions in the conceptual area of motion in secondary school students, in comparison to no treatment group, ( $p < .01$ ).

Table 52 reveals that the concept attainment in pressure after remedial instruction through concept change strategy ( $M=18.53$ ,  $SD = 1.90$ ) shows significantly higher compared to that of the control group ( $M = 9.87$ ,  $SD = 2.18$ ),  $t(95) = 20.46$   $p < .05$ . It can be said that the intervention program for the eradication of misconceptions in pressure through conceptual change strategy is effective. The intervention programme made marked difference in the scores of treatment group. This is evident from Cohen's  $d = 3.96$  implying large effect size. Participative approach significantly and strongly remediates misconceptions in the conceptual area of pressure in secondary school students, in comparison to no treatment control group ( $p < .01$ ).

Table 52 reveals that concept attainment in sound after remedial instruction through participative approach ( $M=3.9$ ,  $SD = .65$ ) is significantly higher compared to that of the control group ( $M = 1.51$ ,  $SD = .97$ ),  $t(95) = 9.19$   $p < .05$ . It can be said that the intervention programme for the eradication of misconceptions in sound through the concept map cum concept change strategy is effective. The intervention programme made marked difference in the scores of treatment group. This is evident from Cohen's  $d = 1.61$  implying large effect size. Participative approach significantly and strongly remediates misconcepts in the conceptual area of sound in secondary school students, in comparison to no treatment control group, ( $p < .01$ ).

## **Discussion**

Paired-samples t-test along with the correlation between the pretest scores has revealed the difference in concept attainment of the experimental and control groups on concept attainment in physics after the remedial instruction

programme. Paired-samples t-tests have also revealed the difference between the experimental and control groups on concept attainment in, sound, pressure, motion, electricity, magnetism, plus light and force, after participative approach, concept map, concept change cum concept map and conceptual change respectively. The experimental and control group were significantly different on concept attainment in the select areas of physics after the experimental intervention employed as the remedial instruction programmes such as participative approach, concept map, concept change cum concept map and conceptual change

### **Conclusion**

From the analysis of data obtained prior to intervention phase it can be concluded that experimental and control group students were equivalent in concept attainment in physics, their level of concept attainment was almost similar in all the major concept areas viz., matter, Solar system, density, velocity, mass, gravity, work, Energy, light, sound, electricity, force, pressure, and magnetism. All the students' possess high rate of misconceptions in all the major concepts. It is found that students having more misconceptions in major concept matter and least in the concept of force. Six major concepts such as magnetism, electricity, pressure, gravity, density and sound exhibited more than fifty percent of misconceptions and in the rest of the seven concepts, six concepts are having misconceptions in between the range forty to fifty percentage. The concept of force showed least misconceptions, which is twenty-three percentages only which is smaller compared to other thirteen misconceptions. Minor concepts off all the major concepts too show severe misconceptions, which lay ninety-one percentages to six percentages. The preliminary survey phase results shows that irrespective of locale and gender of the students they possess around fifty percentage of misconceptions in all concept areas.

In the experimental phase, three intact groups randomly selected for the present study one experimental and two control groups. After administering the pretest to both groups, the groups were matched based on gender and score and obtained a correlation co-efficient of 0.986 which in turn shows that the experimental and comparison groups are 99% matching in academic aspects

After the administration of intervention to treatment group and no treatment to control group, posttest were conducted. The comparison of mean posttest scores shows significant difference between the groups, it can be said that the intervention program for the eradication of misconceptions in physics is effective the coefficient of correlation between posttest scores of two groups the groups are not correlated. Four strategies are used as intervention towards misconceptions they are participative approach, conceptual change strategy by Posner et al, concept map, and conceptual change along with concept map. All strategies were shown effectiveness in remediation where as conceptual change strategy was produced more effect on misconception remediation. The intervention programs made marked difference in the scores of treatment group hence it can be conclude that the intervention done is effective in the remediation of misconceptions in physics.

### **Tenability of Hypotheses**

Tenability of hypotheses formulated for the study were verified in view of the findings and commented below

- 1) Hypothesis 1 states that ‘there will be significant difference in extent of misconceptions among girls and boys of viii standard students of Kerala’.

Analysis of data revealed that there are only three major concepts, viz., pressure, mass, electricity among the fourteen select concepts were found significant difference among boys and girls( $p < .01$ ), hence the hypotheses partially substantiated.

- 2) Hypotheses 2 states that ‘there will be significant difference in extent of misconceptions among rural students and urban students of VIII standard students of Kerala’.

Analysis of data revealed that there is no significant difference in concept attainment among urban and rural students, i.e., there exist no significant locale difference in concept attainment in select fourteen major concepts. Hence, the hypothesis is not accepted.

- 3) Hypotheses 3 states that ‘There will be significant decrease in misconceptions after the implementation of selected experimental instructional strategies in remediating the identified misconceptions in physics’.

Analysis of data revealed that there is significant difference in concept attainment in sound after remedial instruction through participative approach ( $M=3.06$ ,  $SD =.79$ ) is significantly higher compared to that of the control group ( $M =1.74$ ,  $SD = .84$ ),  $t(95) = 7.81$ ,  $p < .05$ . It can be said that the intervention programme for the eradication of misconceptions in sound through participative approach is effective.

Analysis of data revealed that there is significant difference in concept attainment in motion concepts after remedial instruction through concept map approach ( $M=4.59$ ,  $SD =.85$ ) shows significantly higher compared to that of control group ( $M =2.38$ ,  $SD = 1.18$ ),  $t(95) = 10.31$ ,  $p < .05$ . It can be said that the intervention program for the eradication of misconceptions in motion through concept map approach is effective.

Analysis of data revealed that there is significant difference in concept attainment reveals that the concept attainment in pressure after remedial instruction through concept change strategy ( $M=18.53$ ,  $SD =1.90$ ) shows significantly higher compared to that of the control group ( $M =9.87$ ,  $SD = 2.18$ ),  $t(95) = 20.46$   $p < .05$ . It can be said that the intervention program for

the eradication of misconceptions in pressure through conceptual change strategy is effective.

Analysis of data revealed that there is significant difference in concept attainment reveals that concept attainment in sound after remedial instruction through participative approach ( $M=3.9$ ,  $SD = .65$ ) is significantly higher compared to that of the control group ( $M=1.51$ ,  $SD=.97$ ),  $t(95)= 9.19$   $p < .05$ . It can be said that the intervention programme for the eradication of misconceptions in sound through the concept map cum concept change strategy is effective.

Analysis of data revealed that there is significant difference in concept attainment by using the concept attainment strategy, concept map, and participative approach, hence the hypothesis is accepted.

- 4) Hypotheses 3 states that ‘The extent of misconception in physics after remedial instruction will be less in the experimental group than in the control group’.

Analysis of data reveals that the experimental group ( $M=29.27$ ,  $SD =2.77$ ) shows significantly higher concept attainment in selected physics concepts compared to control group ( $M =15.5106$ ,  $SD = 2.40$ ),  $t(95) = 26.20$ ,  $p < .01$ .and it is found significantly effective, hence the hypothesis is accepted.

## **SUMMARY, FINDINGS, AND SUGGESTIONS**

- 
- ↪ **OBJECTIVES OF THE STUDY**
  - ↪ **METHODOLOGY**
  - ↪ **MAJOR FINDINGS OF THE STUDY**
  - ↪ **CONCLUSION**
  - ↪ **EDUCATIONAL IMPLICATIONS OF THE FINDINGS**
-

This chapter is the study in concise. It confines various aspects of the study like variables, objectives, hypotheses and methodology in brief.

### **Objectives of the Study**

Present study was entitled as "Identification of misconceptions in physics and testing of effectiveness of certain instructional programmes on remediation of the misconceptions among VIII standard students in Kerala". This involved identifying frequently occurring misconceptions in physics among secondary school students, and verifying the effectiveness of selected instructional strategies in correcting the identified misconceptions among standard VIII students of Kerala. With these broad objectives, the following specific objectives were set for this study.

1. To find out the percentage of error committed in each of the selected concepts in physics viz., (1) Matter, (2) Solar System, (3) Density, (4) Velocity, (5) Mass, (6) Gravity, (7) Work, (8) Energy, (9) Light, (10) Sound, (11) Electricity, (12) Magnetism, (13 ) Pressure and (14) Force by the secondary school students in the total sample.
2. To find out the percentage of error committed in each of the minor concepts involved in selected concepts in physics viz., (1) Matter, (2) Solar System, (3) Density, (4) Velocity, (5) Mass, (6) Gravity, (7) Work, (8) Energy, (9) Light, (10) Sound, (11) Electricity, (12) Magnetism, (13 ) Pressure and (14) Force by the secondary school students.
3. To identify the major concepts in physics and the minor concepts involved with each of them in which there exists significant difference in the percentage of error between boys and girls among VIII standard students of Kerala.

4. To identify the major concepts in physics and the minor concepts involved with each of them in which there exists significant difference in the percentage of error between rural and urban students of VIII standard students of Kerala.
5. To find out the effectiveness of a range of selected experimental instructional strategies in remediation of the identified misconceptions in physics among VIII standard students of Kerala.

### **Methodology**

This study adopted a mixed method approach. The study was completed in two phases, a survey phase that led to an experimental phase.

#### **Variables in the Survey Phase**

Survey phase of the study explored the misconceptions in physics among secondary school students, in the total sample and subsamples based on gender of students and locale of schools.

##### **Attribute variables.**

Survey phase had the following attribute variables, viz.

- 1) Gender
- 2) Locale of schools

##### **Criterion variables.**

The criterion variables in the survey phase were misconceptions in physics. This variable is explored in terms of misconceptions in fourteen major conceptual areas of physics viz.,

- i. Matter
- ii. Solar system
- iii. Density

- iv. Pressure
- v. Velocity
- vi. Mass
- vii. Force
- viii. Gravity
- ix. Work
- x. Energy
- xi. Light
- xii. Sound
- xiii. Magnetism
- xiv. Electricity

Misconceptions in each of these fourteen areas were further analyzed in terms of the minor concepts involved in each of the major concepts.

### **Variables in the Experimental Phase**

The experimental phase of the study constituted independent variable and dependent variable.

#### **Independent variable.**

The independent variable of the study is instructional method for remediation of misconception referred to as remedial instruction programme. This variable has two levels, the remedial instruction programme, and a no treatment control. Specifically, three conceptual change strategies were employed as instructional programmes for remedying misconceptions in physics. They were conceptual change strategy, concept mapping, and participative approach.

Thus, in addition to the effect of total instructional programmes on total concept attainment in physics, the effects of the three strategies individually and in combination on the concept attainment in select areas of physics were studied.

Hence, the independent variable, remedial instructional programme has four sub-independent variables viz.,

- i. Conceptual change strategy (Vs. no treatment control)
- ii. Concept mapping strategy (Vs. no treatment control)
- iii. Participative approach (Vs. no treatment control)
- iv. Conceptual change cum concept mapping strategy (Vs. no treatment control)

### **Dependent variable.**

The dependent variable of the study is concept attainment in physics. This variable is quantified as the inverse of misconception in physics. The concept attainment in physics in total and concept attainment in four broad areas of physics were analyzed for the studying the effectiveness of select set of instructional strategies. The four subset of dependent variables thus studied were:

- i. Concept attainment in pressure,
- ii. Concept attainment sound,
- iii. Concept attainment motion, and
- iv. Concept attainment in force, density, magnetism, light, and electricity.

### **Sample Used for the Study**

There were two sets of samples used in this study. One sample was used in survey phase and the other in the experimental phase.

#### **Survey sample.**

The present study was conducted on a Stratified random sample of 476 secondary school students from eight schools of Kozhikode, Malappuram and Kasaragod revenue districts with due representation to gender of the pupils and locality of the schools.

### **Sample for experimental phase.**

A sample of 104 standard eight students from a secondary school randomly selected from the eight schools used in survey phase constitute the sample in the experimental phase. Forty-seven students each in experimental and control groups constitute these 104 students. An intact classroom to which an experimental conceptual change programme was imparted is the experimental group. Forty-seven students, formed by individual-to-individual matching with the experimental group on the pretest scores of conceptual attainment in physics and gender was the control group.

### **Tools Used in the Study**

For the present study, the following tools were developed and employed.

- 1) Test of Concept Attainment in Physics - Longer Version (TCAP) (Gafoor and Akhilesh, 2010) and its Abridged Version
- 2) Instructional Programmes on Remediation of the Misconcepts (Gafoor and Akhilesh, 2012)

Lessons based on conceptual change strategies viz., conceptual change, concept mapping, and participative approach to remediate the misconceptions among students in the experimental phase were used.

### **Statistical Analyses Employed**

- i. Percentage Analysis
- ii. Two tailed test of significance of difference between two proportions for large independent samples
- iii. Paired T-test of significance of difference between two means.

## Major Findings of the Study

The major findings of the present study are summarized below.

### Secondary School Students Demonstrate High Incidence of Numerous Misconceptions in Physics Concepts with High Incidence

39 minor concepts in physics showed misconceptions above fifty percentage

Major concept	Minor concept	%
<b>Matter</b>	--- Gases are mass less	90.93
	--- On evaporation Water gets converted into oxygen and hydrogen	70.88
	--- Air is matter	69.69
<b>Solar System</b>	--- Brightness of stars depends only on the distance from earth	70.88
	--- The same side of moon is always seeing from earth	60.38
<b>Density</b>	--- water and oil are immiscible so oil floats over water	83.53
	--- substance should contain air to float	63.24
	--- the reason behind floating of ice is the presence of air inside	58.71
<b>Pressure</b>	--- Atmospheric pressure increases with altitude	68.01
<b>Velocity</b>	--- speed of an object is related to direction	77.32
	--- Velocity is the other name of speed.	55.60
	--- when velocity increases the mass of substance will change	60.14
<b>Mass</b>	--- Mass is equivalent to weight of substance	68.25
<b>Force</b>	--- If an object is at rest there is no force acting on it	62.76
<b>Gravity</b>	--- two metallic objects with different size is allowed to fall from same height the heavier will reach first	84.48

Major concept	Minor concept	%
	--- Gravity is maximum at the centre of earth	66.82
	--- Gravity needs a medium to come in action	66.58
	--- Without air(medium) gravity cannot act through	66.34
<b>Work</b>	--- Wherever force is acting work will be done there	72.79
	--- Work and labor are same	66.11
<b>Energy</b>	--- Object at rest do not possesses any energy	63.72
<b>Light</b>	--- Light rays from an electric bulb travels faster than candle light	85.44
	--- Lakes and sea are found in blue color since they reflects sky	67.54
<b>Sound</b>	--- Sound in air travels faster than that in solid	75.17
<b>Magnetism</b>	--- Electricity can't produce magnetic field	91.40
	--- Smaller magnets are stronger than bigger ones	86.87

**The Different Areas of Physics Vary in their Proneness to Misconceptions, with Matter, Magnetism, Electricity, Pressure, Gravity being More Prone than Force Energy, Mass and Light.**

Concept of Matter shows the highest percentage of misconception (70 percent), whereas the concept of Force showed the least misconceptions (23 percent). In addition to Matter, six other conceptual areas, viz., Magnetism, Electricity, Pressure, Gravity, Density, and Sound demonstrate high rate (>50%) of misconceptions. Six major concepts namely solar system, light, mass, energy, velocity and work exhibit moderate rate (between 50 and 33%) of misconceptions. Only one major concept in physics, i.e., Force, has the modest level (<33 %) of misconception.

Minor concepts of Force, Work, Mass, Energy, Velocity, Light, and Solar System, which are related to daily life situations showed fewer percentage of misconceptions.

**Girls have More Number and Extent of Misconceptions in Physics than Boys, Especially in the Areas of Energy, Solar System and Density**

1. There are significantly higher percentages of misconception among girls, than boys, in the major concepts of Pressure (Girls, 65.56%; Boys, 50.48%, CR =3.37;  $p < .01$ ), Mass (Girls, 52.35%; Boys, 43.35%, CR = 2.01;  $p < .05$ ) and Electricity (Girls, 67.73%; Boys, 62.51%, CR=3.11;  $p < .01$ ).
2. There is no significant difference in percentage of misconception among boys and girls in the eleven major concepts viz., Matter, Solar System, Density, Velocity, Force, Gravity, Work, Energy, Light, Sound, and Magnetism ( $p > .05$ )
  - i. Boys showed misconceptions in 10 minor concepts than girls.
    - a. Light ray travelling through a lens focuses at its centre. (Girls 13.20%; Boys, 35.26%, C.R.= 4.81;  $p < .01$ )
    - b. The surface which absorbs all colours of visible light appears in black where as the (Girls 13.20%; Boys, 35.26%, C.R.= 4.81;  $p < .01$ )
    - c. Surface which reflects all the colors is seen in white (Girls 59.90%; Boys, 80.19%, C.R.= 4.42;  $p < .01$ )
    - d. To have acceleration to a moving body its velocity should be increased (Girls 24.52%; Boys, 42.02 %, C.R.= 3.81;  $p < .01$ )
    - e. Brightness of stars depends only on the distance from earth (Girls 63.67%; Boys, 78.26%, C.R.= 3.18;  $p < .01$ )
    - f. Low density substances float in water (Girls 14.62%; Boys, 28.50%, C.R.= 3.02;  $p < .01$ )

- g. Only a magnet can produce magnetic field (Girls 47.64%; Boys, 60.86%, C.R.= 2.88;  $p < .01$ )
  - h. Unit of speed and acceleration are same (Girls 37.26%; Boys, 50.24%, C.R.= 2.83;  $p < .01$ )
  - i. Displacement is the total distance travelled by the object (Girls 25%; Boys, 37.19%, C.R.= 2.66;  $p < .01$ )
  - j. Energy is the capacity to do work (Girls 9.90%; Boys, 20.28%, C.R.= 2.26;  $p < .01$ )
- ii. 22 minor concepts show significantly higher misconceptions among girls than boys did.
- a. When velocity increases the mass of substance will change (Girls, 64.62%; Boys, 55.55%, C.R.=1.97;  $p < .01$ )
  - b. Gravity needs a medium to come in action (Girls, 71.22%; Boys, 61.83%; C.R.= 2.04;  $p < .01$ )
  - c. Wherever force is acting work will be done there (Girls, 77.83%; Boys, 67.63 , C.R.= 2.22;  $p < .01$ )
  - d. All stars have same size (Girls, 30.18%; Boys, 19.80% , C.R.= 2.26;  $p < .01$ )
  - e. We see one face of moon from India and the other from America (Girls, 58.01%; Boys, 47.34%, C.R.=.32;  $p < .01$ )
  - f. Lakes and sea are found in blue color since they reflects sky (Girls, 73.11%; Boys, 61.83%, C.R.= 2.46;  $p < .01$ )
  - g. Atmospheric pressure increases with altitude (Girls, 74.05%; Boys, 61.83% , C.R.= 2.66;  $p < .01$ )
  - h. Gases are not matter, because they are invisible (Girls, 73.58%; Boys, 60.86%, C.R.= 2.77;  $p < .01$ )
  - i. Pure water is a good conductor of electricity (Girls, 89.15%; Boys, 75.36% , C.R.= 3.00;  $p < .01$ )

- j. Force is that which can only apply by men (Girls, 25%; Boys, 11.11% , C.R.= 3.03;  $p < .01$ )
  - k. Iron is the best conductor of electricity in nature (Girls, 56.13%; Boys, 42.02% , C.R.= 3.07;  $p < .01$ )
  - l. Density and volume influences floating of bodies (Girls, 39.15%; Boys, 24.63% , C.R.= 3.16;  $p < .01$ )
  - m. Displacement and distance are same always (Girls, 58.49%; Boys, 43.96%, C.R.= 3.16;  $p < .01$ )
  - n. Light rays travel in straight line only (Girls, 41.50%; Boys, 26.575, C.R.= 3.25;  $p < .01$ )
  - o. Due to its heaviness a big cube ice can't float (Girls, 50%; Boys, 34.29%, C.R.= 3.42;  $p < .01$ )
  - p. On evaporation Water gets converted into oxygen and hydrogen (Girls, 79.71%; Boys, 61.83% , C.R.= 3.90;  $p < .01$ )
  - q. Pressure in sea bed will be too less than surface (Girls, 57.07%; Boys, 39.13% , C.R.= 3.91;  $p < .01$ )
  - r. Sound can do work (Girls, 44.81%; Boys, 26.57 3.97;  $p < .01$ )
  - s. Moon has its own light (Girls, 50%; Boys, 31.40 C.R.= 3.91 4.05;  $p < .01$ )
  - t. Mass is equivalent to weight of substance (Girls, 79.24%; Boys, 57.00% C.R.= 4.85;  $p < .01$ )
  - u. Some substances floats in water since they are lighter than water (Girls, 79.24%; Boys, 55.55% C.R.= 5.16;  $p < .01$ )
  - v. Work never take place against the applied force, (Girls, 55.18%; Boys, 31.40% C.R.= 5.18;  $p < .01$ )
- iii. Students have misconceptions in minor concepts from the areas solar system light, density, velocity, and sound irrespective of gender.

- iv. Especially, concepts areas namely energy, solar system and density have more minor concepts with higher misconception for girls than boys do.

**Aggregate Rate of Misconceptions in Physics Does not Vary by Urban-Rural Locale of School Students. However, the Exact Nature and Area of Misconceptions Vary by Locale**

1. There is no significant difference in percentage of misconception among rural and urban students in the fourteen major concepts viz., Matter, Solar System, Density, Pressure, Velocity, Mass, Force, Gravity, Work, Energy, Light, Sound, Magnetism and Electricity ( $p > .05$ ).
2. Nine minor concepts in physics shows significantly higher misconceptions among urban than rural did.
  - i. Gases are not matter since they are invisible. (rural, 60.33%; urban, 76.83%, C.R.= 3.55;  $p < .01$ )
  - ii. All metals exist in solid form. (rural, 46.69%; urban, 58.75%, C.R.= 2.59;  $p < .01$ )
  - iii. Sun is not a star. (rural, 30.99%; urban, 58.75%, C.R.= 5.98;  $p < .01$ )
  - iv. If an object is at rest there is no force acting on it. (rural, 54.13%; urban, 74.57%, C.R.= 4.40;  $p < .01$ )
  - v. Work and labour are same. (rural, 61.98%; urban, 71.75%, C.R.= 2.10;  $p < .01$ )
  - vi. Wherever force is, acting work will be done there. (rural, 66.11%; urban, 81.92%, C.R.= 3.40;  $p < .01$ )
  - vii. Light rays travel in straight line only. (rural, 23.55%; urban, 48.58%, C.R.= 5.39;  $p < .01$ )
  - viii. Lakes and sea are found in blue color since they reflects sky. (rural, 61.98%; urban, 75.14%, C.R.= 2.83;  $p < .01$ )

- ix. Light ray travelling through a lens focuses at its centre. (rural, 15.70%; urban, 35.59%, C.R.= 4.28;  $p < .01$ )
- x. Sound needs no medium to travel. (rural, 39.66%; urban, 51.41%, C.R.= 2.53;  $p < .01$ )
- xi. All kinds of sounds make the sense of sound in brain. (rural, 34.29%; urban, 53.67%, C.R.= 4.17;  $p < .01$ )
- xii. All sounds are audible to human ear. (rural, 43.38%; urban, 68.92%, C.R.= 5.50;  $p < .01$ )

3. Nine minor concepts in physics shows significantly higher misconceptions among rural than urban did. They are follows.

- i. Gases are mass less. (rural, 97.10%; urban, 82.4%, C.R.= 3.15;  $p < .01$ )
- ii. On evaporation, Water is converting into oxygen and hydrogen. (rural, 76.85%; urban, 62.71%, C.R.= 3.04;  $p < .01$ )
- iii. Energy of sun never ceases. (rural 59.91%; urban, 49.71%, C.R.= 2.19;  $p < .01$ )
- iv. The same side of moon is always seeing from earth. (rural 67.76%; urban, 50.28 %, C.R.= 3.76;  $p < .01$ )
- v. Pressure in seabed will be too less than surface. (rural 53.30%; urban, 41.24 %, C.R.= 2.59;  $p < .01$ )
- vi. Displacement is the total distance travelled by the object. (rural 40.90%; urban 17.51 %, C.R.= 5.04;  $p < .01$ )
- vii. Acceleration due to gravity is same everywhere. (rural 50.41%; urban 16.94%, C.R.= 7.21;  $p < .01$ )
- viii. Without air, (medium) gravity cannot act through. (rural, 70.24%; urban, 61.01%, C.R.= 1.98;  $p < .01$ )
- ix. Stationary object does not have potential energy. (rural 52.06%; urban 40.67%, C.R.= 2.45;  $p < .01$ )

**Remedial Instructional Programme Employing Conceptual Change Strategies have Strong Effect on Misconceptions in Physics Among Secondary School Students.**

1. Select remedial strategies were effective in the minimization of misconcepts. The experimental group ( $M=29.27$ ,  $SD =2.77$ ) shows significantly higher concept attainment in selected physics concepts compared to control group ( $M =15.5106$ ,  $SD = 2.40$ ),  $t(95) = 26.20$ ,  $p < .01$ .

**Conceptual Change Strategy, Concept Map, Participative Approach, and Concept Map Along with Conceptual Change Strategy Used are Found Effective in Minimization of Misconcepts in Select Areas of Physics.**

1. There is significant difference in concept attainment in sound after remedial instruction through participative approach ( $M=3.06$ ,  $SD =.79$ ) is significantly higher compared to that of the control group ( $M =1.74$ ,  $SD = .84$ ),  $t(95) = 7.81$ ,  $p < .05$ .
2. There is significant difference in concept attainment in motion concepts after remedial instruction through concept map approach ( $M=4.59$ ,  $SD =.85$ ) shows significantly higher compared to that of control group ( $M =2.38$ ,  $SD = 1.18$ ),  $t(95) = 10.31$ ,  $p < .05$ .
3. There is significant difference in concept attainment in pressure after remedial instruction through concept change strategy ( $M=18.53$ ,  $SD =1.90$ ) shows significantly higher compared to that of the control group ( $M =9.87$ ,  $SD = 2.18$ ),  $t(95) = 20.46$   $p < .05$ .
4. There is significant difference in concept attainment in sound after remedial instruction through participative approach ( $M=3.9$ ,  $SD = .65$ ) is significantly higher compared to that of the control group ( $M =1.51$ ,  $SD = .97$ ),  $t(95) = 9.19$   $p < .05$ .

## Conclusion

In general, students have misconceptions in all the content areas especially in matter, magnetism and electricity. Magnetism represents the minor concept, which exhibited highest misconception. Serious problems are present regarding the understanding of the floating of objects and its relation with density and volume. In the case of sound, majority of students think that sound travels faster through air than through objects and all sound waves are audible. In case of work, students think that work and labour are the same. Majority of the students have misconception regarding more than the half of the minor concepts given in the test. About twenty per cent students possess misconception regarding more than eighty per cent of minor concepts tested. Even in the low error exhibiting minor concepts, misconception is well above ten percentages.

Regarding the misconception in physics among boys, they possess misconceptions in the areas, light, velocity, solar system density, sound, and energy. In general boys exhibit misconceptions in definition type and textual ideas e.g., displacement, centrifugal force and volt. We can say about misconceptions in boys that boys exhibit more textual misconceptions and they have the ideas in abstract concept relations than girls. Considering girls, researcher found that they are exhibiting error in abstract concepts and they know the definitions, units etc of a concept. While relationship arises in between concepts they exhibit some problem to recognize. Girls also exhibit more number of misconceptions in minor concepts in physics than boys. In general, we can say that boys have misconception in the textual content area while girls have misconceptions in abstract concepts areas.

While comparing urban and rural school samples, there is no significant difference in misconceptions in major concept areas. Rural students exhibited misconception in minor concepts of eight concept areas where as urban students

showed misconceptions in minor concepts of twelve concept areas, misconceptions in solar system and matter are common in rural and urban students. Rural students exhibited more misconceptions in minor concepts from the areas energy, pressure, velocity and gravity where as urban students posses more misconceptions in minor concepts in the areas sound, light, and work other than solar system and matter.

Misconceptions exhibited by relevant sub samples shows that high school students have serious misconceptions in the areas matter, magnetism and electricity. Some of them have misconceptions in the bases of floating, sound propagation, work-force relation and energy transformation. The science topics temperature, mass energy and gravity etc are to be made more concrete with examples and thereby reduce the textual nature of concepts. In other words, abstract to concrete, translation need to really occur in our physics classrooms. Conceptual change strategies, especially concept mapping, concept change method and participative approach have strong remedial effect on misconceptions in physics among secondary school students.

### **Educational Implications of the Findings**

Based on the results obtained from the present study, some of the practical suggestions offered will be helpful for science teachers and educationalists.

The study indicate that the concepts which are concrete in nature have comparatively low rate of misconceptions and those which involve functional relationships, relation between relations and reference model concepts (abstract concepts) show comparatively high error rate. Hence, the teachers have to keep in mind about these facts about nature of concepts, which have major role in making misconceptions in students mind while designing instruction and framing

of the science curriculum and even for the judicious selection of learning experience.

As indicated in literature review the study also reveals that the manner in which text books are written can also cause misconception eg:- various electricity circuits, splitting of light into spectrum using prisms, the orientation of planets in the milky way in one plans given in text books, pictured of the combination of seven colours making white light can make a sense that only seven colours can make white light instead primary colour also can make white light, textual explanation of energy mass relation etc.

In addition, parents and teachers relay their misconceptions to the children. Often adults have no idea that what they “know” is actually a misconception. This knowledge enables the teachers to avoid regularly occurring misconceptions.

An important finding of the study is that about 50 per cent students possess misconceptions in all the major concepts and found that all types of misconceptions such as preconceived notions, factual misconceptions, vernacular misconceptions and conceptual misunderstanding are existing in students irrespective of gender and locality.

In the gender, wise comparison it is revealed that among girls extent of misconception is higher than boys. Boys are better off than girls in the sense that in understanding the abstract ideas boys are better, girls show higher misconceptions in the areas where more abstract ideas present. While boys have misconception which are more textual in nature, e.g.:- definitions, units, etc. By keeping these factors in mind teacher should organize the teaching style and evaluation procedure by giving weightage to every aspect. Otherwise, one group will be better over other in examinations.

The locality wise comparison of misconception in students revealed that there exist no significant differences in between urban and rural students. In some areas, the misconception in rural students and urban students shows six to eight percentages difference in misconceptions in minor concepts.

The findings from the study helps to make the following specific suggestions for remedying misconceptions in some areas of physics that are much prone to misconceived notions.

1. Provide opportunities for learners to relate concepts learned in school to the daily life experiences.
2. Apply participative approach in correcting misconceptions in areas like acoustics
3. Follow the steps - identification, challenging, application and consolidation - for correcting student misconception.
4. In remedying misconceptions in concepts areas that are tightly integrated to other fundamental concepts in the discipline going through the phases like brainstorming, identification, analysis. categorize, layout representation

### **Suggestions for Further Research**

1. A research to develop remedial measures for the frequently occurring misconceptions that are identified in physics can be done.
2. A research can be done on the effect of teaching on remediation of misconcepts in physics by using different strategies identified.
3. A more elaborate study can be done on teachers to check how far teachers have misconceptions in physics and how they are overcoming it .
4. A detailed study can be done on nature of misconcepts and their areas in physics.

5. A research can be done on role of formal concepts in the formation of misconceptions in physics.
6. An experimental study can be done by using traditional methods and the new methods of instruction to see their effectiveness in attainment of concepts.
7. A set of diagnostic studies can be done on specific physics concepts to know the misconceptions in the minor concepts of that area.
8. A study can be done to categories misconceptions according to their nature such as preconceptions, vernacular, factual and conceptual misconcepts.

## **BIBLIOGRAPHY**

---

- Aguirre, J.M. (1988). Student preconception about vector kinematics. *Physics Teaching*, 26, 212-216.
- Alwan, A.A. (2010). Misconception of heat and temperature among physics students. *Proceedings of social and behavioral sciences*, 12, 600–614. Tripoly.
- Ambrose, B.S. (1999). Student understanding of light as an electromagnetic wave. *Journal of Physics*, 67.
- Anderson, B. (1985). *The experimental gestalt of causation – a common core to pupils’ preconceptions in science*. Department of Education and Educational Research, University of Gothenburg, Sweden.
- Anderson, B. (1989). A study of tertiary physics students conceptualizations of sound. *International Journal of Science Education*, 11, 491-501.
- Anderson, B., & Karrqvist, C. (1981). *Light and its properties*, EKNA Report 8, Institutionen for Praktisk Pedagogik, University of Gothenburg, Sweden.
- Anderson, T.W., & Sclore, S.L. (1974). *Introductory statistical analysis*. Boston: Houghton Mifflin Company.
- Armagan, F., Keskin, O., & Akin, B.S. (2010). Effectiveness of conceptual change texts: a Meta analysis. *Proceedings of Social and Behavioral Sciences*, 9, 1574–1579.
- Asoko, H.M., Leach, J., & Scott, P.H. (1991). *A study of students’ understanding of sound 5-16 as an example of action research*, Paper prepared for the Symposium, ‘Developing Students’ Understanding in Science’ at the Annual Conference of the British Educational Research Association at Roehampton Institute, 2 September 1990, London.
- Ault, C.R., Novak, J.D., & Gowin, D.B. (1988). Constructing vee maps for clinical interviews on energy concepts. *Science Education*, 72(4): 515-45.

- Ausubel, D.P. (1968) *Educational psychology: A cognitive view*. New York: Holt, Reinhart & Winston.
- Bar, V., & Goldmuntz. (1987). *Why things fall*. Scientific Report, Hebrew, University Press, Jersalem.
- Bar, V., & Zinin, B. (1989). *Does a magnet act on the moon?*, Scientific Report, The Amos de Shalit Teaching Centre, Hebrew University, Jerusalem.
- Barbetta, M.G., Loria, A., Mascellani, V., & Michellini, M. (1984). 'An investigation on students' frameworks about motion and the concepts of force and energy', In Lijnse, P. (ed.), *The Many Faces of Teaching and Learning Mechanics in Secondary School and Early Tertiary Education, Proceedings of a Conference on Physics Education, 20-25, August; Utrecht*.
- Barnett, M., & Morran, J. (2002). Addressing childrens alternative frameworks of the moon's phases and eclipse. *International Journal of Science Education, 24*, 859-879.
- Barrow, L.H. (1987). Magnet concepts and elementary students' misconceptions. In Noval, J. (ed.), *Proceedings of the Second International Seminar on Misconceptions and Educational Strategies in Science and Mathematics*. Cornell University, Ithaca, N.Y., 3: 17-22.
- Beaty, W.J. (2000). *Recurring Science misconceptions in k-6 textbooks*. Retrieved, July 30, from <http://www.eskimo.com/~billb/miscon/miscon4.html>.
- Ben-Zvi, R., Eylon, B., & Silberstein, J. (1986). Is an atom of copper malleable?. *Journal of Chemical Education, 63*(1): 64-66.
- Best, J.W., & Khan, J.V. (2006). *Research in education*. New Delhi: Prentice Hall India Ltd.
- Bigozzi, L., Tarchi, C., & Falsin, P. (2014). 'Slow Science': Building scientific concepts in physics in high school. *International Journal of Science Education, 36*, 2221-2242.

- Black, P. J., & Lucas, A. M. (Eds.). (1993). *Children's informal ideas in science*. London: Routledge
- Bliss, J., & Ogborn, J. (1985). 'Children's choices of uses of energy', *European Journal of Science Education*, 7(2): 185-203.
- Bloom, B.S. (1956). *Taxonomy of Educational objectives Book 1: Cognitive Domain*. New York: David Madey.
- Borreguero, G.M., & Rodriguez, A.L. (2013). *Detection of misconceptions about Colour and an Experimentally Tested Proposal to Combat them*. *International Journal of Science Education*, 35(8), 1299–1324.
- Bouma, H., Brandt, I., & Sutton, C. (1990). *Words as Tools in Science Lessons*. Chemiedidactiek, University of Amsterdam.
- Boyle, R.K., & Maloney, D.P. (1991). Effect of written text on usage of Newton's third law. *Journal of Research in Science Teaching*, 28, 123-140.
- Brook, A., & Driver, R. (1984). *Aspects of secondary students' understanding of energy: Full report*. Centre for Studies in Science and Mathematics Education, University of Leeds.
- Brook, A., & Driver, R., in collaboration with Hind, D. (1989). *Progression in Science: Development of pupils' understanding of Physical characteristics of air across the age range 5-16 years*. Centre for Studies in Science and Mathematics Education, University of Leeds.
- Brown, A., David, S., & Clement, John. (1987). Misconception concerning Newton's law of action reaction. *Proceedings of the Second International Seminar Misconceptions and Educational Strategies in Science and Mathematics*. Cornell University, 3, 39-54.
- Brown, D.E. (1989). Students concepts of forces: the importance of understanding Newton's third law. *Physical Education*, 24, 353-357.

- Brown, H.J. (1977) Perception. *Theory and Commitment-The New philosophy of Science*, Precedent, Chicago.
- Caillot, M., & Xuan, A.N. (1993). Adult misconception in electricity. *In the Proceedings of Third International Seminar on Misconceptions and Educational Strategies in Science and Mathematics*. Ithaea, New York: misconception trust.
- Callison, P. L., & Wright, E. L. (1993, April). *The effect of teaching strategies using models on preservice elementary teachers' conceptions about relationships*. Paper presented at the meeting of National Association for Research in Science Teaching, Atlanta: GA.
- Cantu, L.L., & Herron, J.D. (1978). Concrete and formal piagetian stages and science concept attainment. *Journal of Research in Science Teaching*, 15, 413-419.
- Caramazza, A., Mcdoskey, M. & Green, B. (1981). Naive beliefs in sophisticated subjects: Misconceptions about trajectories of objects. *Cognition*, 9, 117-123.
- Caravita, S., & Hallden, O. (1994) Re-Framing the problem of conceptual change. *Learning and Instruction*, 4, 89-111.
- Carey, S. (1985). *Conceptual change in childhood*. Cambridge: MA, MIT.
- Carey, S. (1991). Knowledge acquisition: Enrichment of conceptual change? In S. Carey & R. Glenman (Eds.), *The Epigenesis of Mind* (pp. 257-291). Hillsdale, NJ: Erlbaum.
- Champagne, A., Klopfer, L., & Anderson, J. (1979). *Factors influencing learning of classical mechanics*. Paper presented at A.E.R.A. meeting, Sanfrancisco.
- Champagne, A., Klopfer, L., & Anderson, J. (1980). Factors influencing the learning of classical mechanics. *American Journal of Physics*, 48, 1074–1079.

- Champagne, A.B, Gunstone, R.F., & Klopfer, L.E (1985). Effective changes in cognitive structures among physics students. In L.H.T. West & A.L. Pinees (Eds.), *Cognitive structures and conceptual change* (pp. 163-187). New York: Academic Press.
- Chi, M. T. H. (1992) Conceptual change within and across ontological categories: examples from learning and discovery in science, in: R. Giere (Ed.) *Cognitive models of science: Minnesota studies in the philosophy of science*. Minneapolis: University of Minnesota Press, 129–160
- Clement, J. (1977). *Catalogue of students conceptual models in physics*. Department of Physics and Astronomy, University of Massachusetts,
- Clement, J. (1982). Students' preconceptions in introductory mechanics. *American Journal of Physics*, 50, 66–71.
- Clement, J., Brown, O., & Zietsman, A. (1989). Not all preconceptions are misconceptions: finding anchoring conceptions for grounding instruction on students intuitions. *International Journal of Science Education* 11(5): 554-565.
- Committee on undergraduate science education (1996). *Science teaching recognized: A hand book by the National Academy Press*.
- Cosgrove, M., & Osborne, R. (1985). Lesson Frameworks for changing childrens ideas. In *Learning in Science: The implications of childrens science*.
- Dai, M.F., & Cupib, W. (1990 April). *Misconceptions about the moon held by preservice teacher in Taiwan*. ERIC Document Reproduction Service No. ED. 325327.
- Deberg, K.C. (1995). Student understanding of Volume. *Journal of Research in Science*, 32, 871-884.
- Dove, J. (2002). Does the man in the moon ever sleep? An analysis of student answers about simple astronomical events: A case study. *International Journal of Science Education*, 24, 823–834.

- Dow, W.M., Auld, J., & Wilson, D. (1978). *Pupils concepts of gases, liquids and solids*. Dundee College of Education.
- Driver, R. (1983). 'An approach to the documenting of understanding of fifteen year old British children about particulate theory of matter.' In *Research on Physics Education*, Proceedings of the first International workshop, La Londe les Maures, pp. 339-46.
- Driver, R. (1994). *Making sense of secondary science: Research into childrens ideas*. London: Routledge.
- Driver, R., & Easley, J. (1978). Pupils and paradigms: A review of literature related to concept development in adolescent science students. *Studies in Science Education*, 5, 61-84.
- Driver, R., & Easley. (1978). Pupils and paradigms: a review of literature related to concept development in adolescent science students. *Studies in Education*, 28, 843-900.
- Duit, R. (1981). 'Students' notions about energy concept- before and after physics instruction'. In Jung, W., Pfunt, H., & Rhoneck, C. von (Eds.), *Proceedings of the International Workshop on Problems Concerning Students' Representation of Physics and Chemistry Knowledge*, 14-16, September, Pedagogische Hochschule, Ludwigsburg, pp. 268-319.
- Duit, R. (1983). 'Energy conceptions held by students and consequences for science teaching'. In Helm, H., & Novak, J.D. (Eds.). *Proceedings of the International Seminar: Misconceptions in Science and Mathematics*, 20-22 June, 1983, Cornell University, Ithaca, New York: 316-23.
- Duit, R. (1984) 'Work, force and power-words in everyday language and terms in mechanics', in Lijnse, P. (ed.), *The Many Faces of Teaching and Learning Mechanics in Secondary and Early Tertiary Education*, Proceedings of a Conference on physics education, 20-25 August, Utrecht; GIREP/SVO/UNESCO, WCC, Utrecht, 1985: 221-33.

- Duit, R., Treagust, D.F., Widodo, A. (2008). Teaching Science for Conceptual change: Theory and practices. In Stella Vosniadu (Ed.), *International hand book on conceptual change* (pp.629- 646). New York: Routledge.
- Duit, R., Widodo, A., & Wodzinsky, C.T. (2007). *Conceptual change ideas- Teachers views and their instructional practice, reframing the problem of conceptual change in learning and instruction* (pp.197-217). Amsterdam, the Netherlands: Elsevier.
- Dykstra, D.I., Boyle, C.F., & Monarch, I.A. (1992) Studying conceptual change in learning physics. *Science Education*, 76, 615–652.
- Eaton, J.F., Anderson, C.W., & Smith, E.L. (1983). *Students' misconceptions interfere with learning: Case studies of fifth-grade students*. Retrieved from ERIC Database (ED 228094).
- Eckstein, S.G., & Shemesh, M. (1993). Stage theory of the development of alternative conception *Journal of Research in Science Teaching*, 30, 45-64.
- Ellse, M., & Honeywill, C. (2001). *Fields, forces and synthesis*. Retrieved, August 26, [http:// www.nelsonthornes.com /secondary/science/ nas\\_new /html/sample\\_pdfs/fields\\_20\\_29.pdf](http://www.nelsonthornes.com/secondary/science/nas_new/html/sample_pdfs/fields_20_29.pdf)).
- Engel Clough, E., & Driver, R. (1985). 'Wht do children understand about pressure in fluids.?' *Research in Science and Technology Education*, 3(2): 133-4.
- Erickson, G., & Hobbs, E. (1978). *The developmental study of student beliefs about force concepts*. Paper presented to the 1978 Annual Convention of the Canadian Society for the Study of Education. 2 June, London, Onatrio, Canada.
- Erickson, G.L. (1979). Children's conceptions of heat and temperature, *Science education*, 63, 221-230.

- Eshach, H (2010) *An Analysis of conceptual flow patterns and structures in the physics classroom*. International Journal of Science Education Vol. 32, 451–477.
- Eylon, B. S., & Ganiel, U. (1990) Macro-micro relationships: the missing link between electrostatics and electrodynamics in students' reasoning, *International Journal of Science Education*, 12, 79–94.
- Feher, E., & Rice, K. (1985). *Showing shadow shapes: Activities to elicit and dispel some preconceptions*. Paper submitted to Science and Children.
- Ferguson, G.A. (1981) *Statistical analysis in psychology and education*. Tokyo: McGraw Hill.
- Finley, F.N. (1986). 'Evaluating instruction: The complementary use of clinical interviews'. *Journal of Research in Science Teaching*, 23(17): 635-50.
- Fisher, K.M. (1983). In H. Helm & J. D. Novak (Chairs). *Proceedings of the international seminar on misconceptions in science and mathematics*. Ithaca, NY: Cornell University.
- Flavell, J.H. (1971). Stage-related properties of cognitive development. *Cognitive Psychology*, 2(4), 421–453.
- Franco *et. al.* (2011). Examining the influences of epistemic beliefs and knowledge representations on cognitive processing and conceptual change when learning physics. *Learning and Instruction*, 22, 62-77.
- Furio C., & Guisosolal, J. (1998). Difficulties in learning. The concept of electric field. *Science Education*, 82, 511-526.
- Gabel, D.L., & Samuel, K.V. (1987). 'Understanding of the particulate nature of matter.' *Journal of Chemical Education*, 64(8): 695-7.
- Gafoor, K.A., & Akhilesh, P.T. (2008). Misconceptions in physics among secondary school students. *Journal of Indian Education*, 34.

- Gafoor, K.A., & Akhilesh, P.T. (2010). Teachers beliefs about present day classroom practices in school. *GCTE Journal of Research and Extension in Education*, 5.
- Gafoor, K.A., & Akhilesh, P.T. (2013). Strategies for facilitating conceptual change in school physics. *Innovations and Researches in Education* , 3.
- Galili, I. (1993) Perplexity of the field concept in teaching-learning aspect, in: *The Proceedings of the Third International Seminar on Misconceptions and Educational Strategies in Science and Mathematics*. Ithaca, NY: Misconceptions Trust.
- Garret, H.E. (1979). *Statistics in psychology and education*. Bombay: Vakils, Ferror and Simon Ltd.
- Gilbert, J. K., & Swift, D. (1985). Towards a Lakatosian analysis of the Piagetian and alternative conceptions research programs. *Science Education*, 69, 681–696.
- Gilbert, J.K., & Watts, D.M., Osborne, R. (1980). *Eliciting student views using an interview about instances technique*. Symposium paper presented at the A.E.R.A. Conference, Los Angels.
- Goldberg, F.M., & Anderson, J.H. (1981). Student difficulties with graphical representation of negative value of velocity. *Physics Teaching*, 27, 254-260.
- Gordon, J. (1996). Tracks for learning: Meta cognition and learning technologies. *Australian Journal of Education Technology*, 12, 1301-1310.
- Guesne, E. (1985). 'Light'. In Driver, R., Guesne, E. & Tiberghien, A. (Eds.), *Children's Ideas in Science*, Open University Press, Milton Keynes.
- Gunstone, R., & Watts, D.M. (1985). 'Force and motion'. In Driver, R., Guesne, E., & Tiberghien, A. (Eds.), *Children's Ideas in Science*, Open University Press, Milton Keynes, pp. 85-104.

- Gunstone, R.F., & White, R.T. (1981) Understanding gravity, *Science Education*, 65, 291–299.
- Guruswamiy, C. (1997). Students understanding of the transfer of charge between conductors. *Physics Education*, 32, 91-96.
- Guzzetti. (2000). Learning counter intuitive science concepts; what we have learned over a decade of research?. *Research and Writing Quarterly*, 16.
- Hammer. (1989). The nature of naïve explanations of natural selection. *International Journal of Science Education*, 20, 1231-1250.
- Hermann, R., & Lewis, B. F. (2003). Moon misconceptions. *The Science Teacher*, 11, 51–55.
- Herrnon, J.D., Canty, L.L., Ward, R., & Srinwan, V. (1977). Problems associated with concept analysis. *Science Education*, 61, 185-199.
- Hestenas, D. (1987). Toward a modeling theory of physics instruction: *American Journal of Physics*, 55, 440-454.
- Hewson, M.G., & Hewson, P.W. (1982). Effect of instruction using student's prior knowledge and conceptual change strategies on science learning. *Journal of Research in Science Teaching* 20, 731-743.
- Hewson, P., & Hewson. M. (1991). *The States of Students Conceptions Research in Physics Learning: Theoretical Issues and Empirical Studies*. Kiel: Institute for Science Education at the University of Kiel.
- Holding, B. (1987). *Investigation of school children's understanding of the process of dissolving with special reference to the conservation of mass and the development of atomistic ideas*, Unpublished PhD thesis, University of Leeds.
- Inhelder, B., & Piaget, J. (1958). *The Growth of Logical Thinking from Childhood to Adolescence*. New York: Basic Books.

- Ivowi, U.M.O., & Oludotun, J.S.O. (1987) An Investigation of sources of misconceptions in physics *Proceedings of the Second International Seminar Misconceptions and Educational strategies in Science and Mathematics*. Cornell University, 3, 252 – 257
- Johnstone (1977). Misconceptions in school thermodynamics. *Physics Education*, 12, 248-251.
- Jones, E.R., & Childers, L.R. (1992). *Contemporary college physics (2<sup>nd</sup> edn)*. New York: Addison-Westey publishing company.
- Kagan, J. (1966). Reflection-impulsivity: The generality and dynamics of conceptual tempo. *Journal of Abnormal Psychology*, 71(1), 17-24. doi: 10.1037/h0022886
- Kagan,j (1966). *Reflection-impulsivity: The generality and dynamics of conceptual tempo*.Journal of Abnormal Psychology, Vol 71(1), Feb 1966, 17-24. doi: 10.1037/h0022886
- Karplus, R. (1969). *Project development theory: Formal thought*. San Francisco, California: Davidson Film producers.
- Kuhn, T. (1962). *The structure of scientific revolutions*. Chicago: Chicago press.
- La Rosa, C., Mayer, M., Patrizi, P., & Vincentini, M. (1984). ‘Commonsense knowledge in optics: Preliminary results of an investigation of the properties of light’, *European Journal of Science Education*, 6(4): 387-97.
- Lawson, A. E., & Nordland, F. H. (1977). Conservation reasoning ability and performance on BSCS blue version examination. *Journal of Research in Science Teaching*, 14, 69-74.
- Lawson, A.E., & Runner, J.W. (1975). Relationship of science subject matter and development levels of learners. *Journal of Research in Science Teaching*, 12, 347-348.

- Lawson, R.A., & McDormolle, L.C. (1987). Student understanding of the work energy and impulse-momentum theorems. *American Journal of Physics*, 55, 811-817.
- Leboutet-Barrell, L. (1976). 'Concepts of mechanics among young people.' *Physics education* 20: 462-5 .
- Linder, C.J., & Erickson, G.L. (1989). 'A study of tertiary physics students' conceptualizations of sound', *International Journal of Science Education*, 11, Special Issue, 491-501.
- Lindor, Cedric J. (1993). A challenge to conceptual change. *Science Education*, 77, 293-300.
- Linn, M. C., & Levine, D. I., (1978). Adolescent reasoning: Influence of question format and type of variables on ability to control variables. *Science Education*, 62, 377-388.
- Lovell, K. (1966). *The Growth of Mathematical and Scientific Concepts in Children*. London: University of London Press.
- Maloney, D.P. (1985) 'Rule governed physics: some novice predictions', *European Journal of Science Education*, 7(3): 295.
- Maloney, David P. (1990) Forces as interactions. *The Physics Teacher*, 28, 386 – 390.
- Mantyla, T. (2012). Promoting Conceptual Development in physics teacher education: cognitive-historical reconstruction of electromagnetic induction law. *Science and Education*, 22, 1361–1387.
- Marioni, Cesare. (1989). Aspects of student's understanding in classroom settings: Case studies on motion and inertia. *Physics Education*, 24, 273 - 277.

- Martin-blas, T., Seidel, L., & Serrano-fernández, A. (2010). Enhancing force concept inventory diagnostics to identify dominant misconceptions in first-year engineering physics. *European Journal of Engineering Education*, 35(6), 597–606.
- Mas, C.J.F., Peres, J.H., & Harris, H. (1987). ‘Parallels between adolescents’ conception of gases and the history of chemistry.’ *Journal of Chemical Education*, 64(7): 616-18
- Maurines, L. (1992). Spontaneous reasoning. *Journal of Science Education*, 14, 279-293.
- McCloskey, M. (1983). *Naïve theories of motion*. In D. Gentner & A.Stevens (Eds.), *Mental models* (pp.299-324). Hillsdale, NJ: Erlbaum.
- McCloskey, M., Caramazza, A., & Green, B. (1980). Curvilinear motion in the absence of external force: Naïve beliefs about the motion of objects. *Science*, 210, 1139-1141.
- McComar, L.F. (1990). Ten myths of science: Reexamining what we think we know. *School Science and Mathematics*, 98, 10-17.
- McDermott, L.C., Rosencrust, M.L., & Vanzee, E.H. (1987). Student difficulties in connecting graphs and physics. *American Journal of Physics*. 55, 503-513.
- Mckinnon, J. (1971). Earth science and density. *Physics Education*, 19, 218-220.
- McMillan, C., & Swadner, M. (1991) Novice use of qualitative versus quantitative problem solving in electrostatics. *Journal of Research in Science Teaching*, 28, 661–670.
- Michael, C. (1999). Making sense of mechanical wave. *Journal of Physics*, 67, 20-21.
- Miller, B.W., & Brewer, W.F. (2010). Misconceptions of astronomical distances. *International Journal of Science Education*, 32(12), 1549–1560.

- Minstrell, J. (1982). 'Explaining the "at rest" condition of an object', *The Physics Teacher*, 20: 10-14.
- Mullet, E., & Gervais, H. (1990). 'Distinction between the concepts of mass and weight in high school students'. *International Journal of Science Education*, 12(2): 217-26.
- Niedderer, H. (1987). A teaching strategy based on students alternative frameworks-theoretical conceptions and examples. In Proceedings of the second international seminar. *Misconceptions and Educational strategies in Science and Mathematics 2*:360-367, Cornell University.
- Novick, S. and Nussbaum, J. (1978). 'Junior high school pupils understanding of the particulate nature of matter: An interview study.' *Science Education*, 62(3): 273-81
- Nussbaum, J., & Novak, J.D. (1976). An assessment of children's concepts of earth using structural interviews. *Science Education*, 60,535-550.
- Nussbaum, J, & Novick, S. (1982). Alternative frameworks conceptual conflict and accommodation: Towards a principle teaching strategy. *Instructional Science*, 11, 183-200.
- Odom, A. L., & Barrow, L. H. (1995). Development and application of a two-tier diagnostic test measuring college biology students' understanding of diffusion and osmosis after a course of instruction. *Journal of Research in Science Teaching*, 32, 45-61.
- Ohanian, H.C. (1989) *Physics* (2nd edn.). New York: W.W. Norton & Company.
- Osborne, J., Black, P., Smith, S., & Meadows, J. (1990). *Light Research Report*. Primary SPACE project, Liverpool University Press.
- Osborne, R. (1980). *Force*. LISP Working Paper 16, Science Education Research Unit, University of Waikato, Hamilton, New Zeland.

- Osborne, R., & Freyberg, P. (1985). *Learning in science: The implications of children's science*. Oxford, UK: University of Oxford Press.
- Parker, J., & Hey Wood, D. (1998). The earth and beyond: Developing primary teacher understanding of basic astronomical events. *International Journal of Sciences Education*, 20, 503-520.
- Pase, S., Rarpadas, J., & Kumar A. (1994). Alternative conceptions in Galilean relativity: Frames of reference. *Journal of Science Education*, 16, 63-82.
- Pella, M.O. (1966). *Referents to scientific literacy*. *Journal of Research in Science Teaching*, 4(3), 199-208.
- Peters, P.C. (1981). Even horrors students have conceptual difficulties with physics. *American of Physics*, 50, 501-508.
- Pfundt, H. (1981). 'The atom – the final link in the division process or the first building block ? Pre- instructional conceptions about the structure of substances', *Chemica Didactica*, 7: 75-94.
- physics classroom. *International Journal of Science Education* Vol. 32, 451-477.
- Piaget, J. (1950). *The psychology of intelligence*. New York: Harcourt Brace.
- Piaget, J. (1964) Development and learning. *Journal of Research in Science Teaching* 2: 176-186.
- Piaget, J. (1973). *La Formation de la notion de force, Etudes d'epistemologie genetique* (Vol. XXX), Paris Presses, Universite de France.
- Piaget, J. (1973). *The child's conception of world*. London: Paladin.
- Piaget, J. (1977). *The development of thought*. A. Rosin, (Trans), Blackwell, Oxford.
- Podolner, R.S. (2000). *Eradication physical misconceptions using the conceptual change method*. Retrieved, August 26, from [http:// www.kzoo.edu/ede/prodolonersip.pdf](http://www.kzoo.edu/ede/prodolonersip.pdf).

- Popham, L.J., & Sirotnik, K.A. (1975). *Educational Statistics: use and interpretation*. New York: Harper & Row.
- Posner, G.J., Stricke, K.A., Hewson, P.W., & Gertzog, W.A. (1982). Accommodation of a scientific conception: Toward a theory change. *Science Education*, 66, 211-227.
- Posner, G.J., Strike, K.A., Hewson, P.W., & Gertzog, W.A. (1982). Accommodation of a scientific conception: toward a theory of conceptual change. *Science Education*, 66, 211–227.
- Rainson, S., Transtromer, G., & Viennot, L. (1994). Students' understanding of superposition of electric fields, *American Journal of Physics*, 62, 1026–1032.
- Ramadas, J., & Driver, R. (1989). *Aspects of secondary students' ideas about light*. Children's Learning in Science Project, Centre for Studies in Science and Mathematics Education, University of Leeds.
- Ramdas S.J., Barre, S.K., & Kumar A. (1996). Alternative conception in Galilian relativity: inertial and non inertial observer. *Journal of Science Education*. 18, 615-629.
- Renner J.W., Abraham, M.R., Grzybowski, E.B., & Marek E. (1990). Understandings and misunderstandings of eighth graders of four physics concepts found in textbooks. *Journal of Research in Science Teaching* 27, 35- 54.
- Rider, S. (2002). Perceptions about moonphaser. *Science Scope*, 6, 48-51.
- Roach Linda E. (1992) Demonstrating Newton's third law *The Science Teacher*, 24, 28 – 31.
- Rosemary A, M.(2014) *Possible impact on science misconceptions as a result of instructional intervention* 2014 GSA Annual Meeting in Vancouver, British Columbia (19–22 October 2014) Paper No. 304-9.

- Rowell, J.A., & Dawson, C.J. (1985). Equibrational conflict and instruction: Anew class oriented perspective. *European Journal of Science Education* 4(4): 331-344.
- Sackes, M., Trundle, K.C., Bruce W.T., & Krissek, L.A. (2012). Development of the efficacy beliefs for conceptual change learning questionnaire. *The Journal of Experimental Education*, 80(4), 338–351.
- Sahin, M. (2010). The impact of problem-based learning on engineering students' beliefs about physics and conceptual understanding of energy and momentum. *European Journal of Engineering Education*, 35(5), 519–537.
- Saltiel, E., & Malgrange, J.L. (1980). Spontaneous Ways of reasoning in elementary kinamature. *European Journal of Physics*, 1, 73-80.
- Sandanad, N.J., & Kess, J. (1990). Concept us force and motion the *physics teacher*, 28, 530-533.
- Sanger, M.J., & Greenbowe, T.J. (1999). An analysis of college of chemistry textbooks as sources of misconception and errors in electrochemistry, *Journal of Chemistry Education*, 76, 853–860.
- Savelsberg, E.R., Jong, T., & Furgosen, H. (2002). Situational knowledge in physics: In the case of electro dynamics. *Journal of Research in Science Teaching*, 29, 928-951.
- Schultz K., Murray T., Clement J., & Brown, D. (1987). Overcoming misconceptions with a computer based tutor *Proceedings of the Second International Seminar Misconceptions and Educational Strategies in Science and Mathematics*. Cornell University, 3, 434-448.
- Scott, P.H., Asoko H.M., & Driver R.H. (1991). Teaching for conceptual change: a review of strategies *Research in Physics Learning: Theoretical Issues and Empirical Studies* (pp. 320-329). Institute for Science Education at the University of Kiel.

- Scott, P.H., Asoko, H.M., & Driver, R.H.(1992). Teaching for conceptual Change: A review of strategies. In R. Duit, F. Goldberg, H. Niederer (Eds.), *Research in Physics Learning: Theoretical issues and empirical studies* (pp, 310-329). Kiel, Germany: IPN-Leibniz Institute of Science Education
- Selman, R.L., Krupa, M.P., Stone, C.R., & Jacquette, D.S. (1982). 'Concrete operational thought and the emergence of the concept of unseen force in children's theories of electromagnetism and gravity'. *Science Education*, 66 (2), 181-94.
- Sere,M.G.(1986). 'The gaseous state'. In Driver, R., Guesne, F., & Tiberghien, A. (Eds.), *Childrens' ideas in science* (pp.105-23). Mileton Keynes: Open University Press.
- Sexena, A.B. (1991). The understanding of properties of light by students in India. *International Journal of Science Education*, 13, 283-289.
- Shevlin, J. (1989). 'Children's prior conceptions of force aged 5-11 and their relevance to attainment Target 10 of the National Curriculum of Science', Unpublished M.Ed. Thesis, University of Leeds.
- Shipstone, D.M. (1984). 'A study of children's understanding of electricity in simple DC circuits', *European journal of science education* 6(2): 185-98
- Shipstone, D.M. (1985). 'Electricity in simple circuits.', in Driver, R., Guesne, E. and Tiberghien, A. (Eds.), *Children's ideas in science* , Open university press, Milton Keynes ,pp. 33-51.
- Siegel, A.M., & Lee, J.A.C. (2001). Bel electricity static: Science discussion, identification of learning issues, and use of resources in a problem learning course: *Paper Presented at the Annual Meeting of the National Associations for Research in Science Teaching*. St. Louis.
- Solomon, J. (1983). Learning about energy: How pupils think in two domains. *European Journal of Science Education*, 5(1): 49-59.

- Sornkhatha, P., & Srisawasdi, N. (2012). *Supporting conceptual development in Newton's laws of motion using an interactive computer-simulated laboratory environment*: Third world Conference on learning, Teaching and educational leadership -WCLTA, Taiwan.
- Srinivasan, (1977). *Problems associated with concept analysis*. Article first published online: 21 AUG 2006. doi: 10.1002/sce.3730610210.
- Stahly, L.L., Krockover, G.I., & Shepardson, D.P. (1999). Third grade students' ideas about the lunar phases. *Journal of Research in Science Teaching*, 36, 159–177.
- Stavy, R. (1980). Using analogy to overcome misconceptions about conservation of matter. *Journal of Research in Science Teaching*, 28(4):305-313.
- Stavy, R. (1990). 'Children's conception of changes in states of matter:from liquid (or solid ) to gas.' *Journal of Research in Science Teaching*, 27(3): 247-66.
- Stead, B. (1980). 'Messy, contradictory and obstinately persistent: A study of children's out of school ideas about energy'. *School Science Review*, 65(231): 225-33.
- Stead, B.F., & Osborne, R.J. (1980). *Exploring students' understanding of light and its properties following a teaching strategy to engender conceptual change*. Paper presented to the annual meeting of the American Educational Research Association, 16-20, April, Boston.
- Summers, M., & Mant, J. (1995). A survey of British primary school teachers' understanding of the Earth's place in the universe. *Educational Research*, 37, 3–19.
- Suzuki, M. (2003). Conversations about the moon with prospective teachers in Japan. *Science Education*, 87, 892–910.

- Tao, P. K., & Gunstone, R. F. (1999). The process of conceptual change in force and motion during computer supported physics instruction. *Journal of Research in Science Teaching*, 36, 859 – 882.
- Taylor, I., Barker, M., & Jones, A. (2003). Promoting mental model building in astronomy education. *International Journal of Science Education*, 25, 1205–1225.
- Terry, C., Jones, G., & Hurford, W. (1985). ‘Children’s conceptual understanding of force and equilibrium’. *Physics Education*, 20(4): 162-5.
- Thacker, B.A., Ganiel, U., & Boys, D. (1999). Macroscopic phenomena and microscopic processes: Student understanding of transients in direct current electric circuits, *American Journal of Physics*, 67, S25–S31.
- Thagard, P. (1991) Concepts and conceptual change. In J.H. Fetzer (Ed.) *Epistemology and cognition*. Dordrecht: Kluwer.
- Tiberghien, A., Delacote, G., Ghiglione, R., & Metalon, B. (1980). ‘Conceptions de la lumiere chez l’enfant de 10-12 ans’. *Revue Francoise de Pedagogie*, 50: 24-41.
- Tobias, S. (1987). In class methods for getting at student misconceptions *Proceedings of the Second International Seminar Misconceptions and Educational Strategies in Science and Mathematics*. Cornell University 514 -516
- Tornkovist, S., Petterson, K.A., & Transtromer, G. (1993). Confusion by representation: On student’s comprehension of the electric field concept. *American Journal of Physics*, 61, 335–338.
- Towbridge, D.E., & McDermott, L.C. (1981). Investigation of student understanding of concept of acceleration in one dimension. *American Journal of Physics*, 49, 242–253.
- Trowbridge, D.E., & Mc Dermott, L.C. (1980). Investigation of student understanding of the concept of velocity in one dimension, *American Journal of Physics*, 48, 1020-1028.

- Trumper, R. (2003). The need for change in elementary school teacher training: A cross-college age study of future teachers' conceptions of basic astronomy concepts. *Teaching and Teacher Education, 19*, 309–323.
- Trundle, K.C., Atwood, R.K., & Christopher, J.E. (2002). Pre-service elementary teachers' conceptions of moon phases before and after instruction. *Journal of Research in Science Teaching, 38*, 633–658.
- University of Massachusetts Physics Education Research Group (2000). *Research results relevant to education in physics*. Retrieved, August 26 from [http:// www.umpporg. physics.umass edu/perspective/research findings](http://www.umpporg.physics.umass.edu/perspective/researchfindings).
- Viennot, L. (1979). Spontaneous reasoning in elementary dynamics. *European Journal of Science Education, 2*, 205-221.
- Vosniadou, S. (1994) Capturing and modelling the process of conceptual change (special issue): *Learning and Instruction, 4*, 45–69.
- Vosniadou, S. (2004). Extending the conceptual change approach to mathematics. *Learning, Teaching and Instruction, 14*, 445-451.
- Wandersee, J.H., Mintzes, Joel J., & Novak Joseph, D. (1994). Research on alternative conceptions in science in Gabel, Dorothy J. *Handbook of Research on Science Teaching and Learning*. New York: MacMillan.
- Warren, J.W. (1942). The teaching of concept of heat. *Physics Education, 7*, 41-44.
- Watt, D., & Russell, T. (1990). *Sound*. Primary SPACE Project Research Report, Liverpool University Press.
- Watts, D.M. (1984). 'Learners' alternative frameworks of light'. In bell, B., Watts, M., & Ellington, K. (Eds.), *Learning, Doing and Understanding in Science* (pp. 69-72), The Proceedings of a conference, Woolley Hall, England, 11-13, July, SSCR, London.

- Watts, D.M., & Gilbert, J.K. (1985). *Appraising the understanding of science concepts: Light*. Department of Educational Studies, University of Surrey, Guildford.
- White, R., & Gunstone, R. (1992). *Probing understanding*. London: The Falmer Press
- White, R.T. (1992) Implications of recent research on learning for curriculum and assessment, *Journal of Curriculum Studies*, 24, 153–164.
- Word, G.R., Narrender, N., Lucas, C., & Herry J.D. (1978). *Evaluation of the longest test of cognitive department*. West Lafayette, Indiana: Pardu University.
- Zeilik, M., Schau, C., & Mattern, N. (1998). Misconceptions and their change in university-level astronomy courses. *The Physics Teacher*, 36, 104–107.
- Zylbersztajn, A., & Watts, D.M. (1982). 'Throwing some light on colour', Mimeograph, University of Surrey, Guildford.

## **APPENDICES**

---

UNIVERSITY OF CALICUT  
DEPARTMENT OF EDUCATION

TEST OF CONCEPT ATTAINMENT IN PHYSICS (TCAP)  
LONGER VERSION (DRAFT)

**Dr. K. Abdul Gafoor**  
Associate Professor

**Akhilesh, P.T.**  
Research Scholar

---

1. വാതകങ്ങൾ പദാർത്ഥങ്ങളല്ല കാരണം അത് അദൃശ്യമാണ്.
2. വാതകങ്ങൾക്ക് പിണ്ഡം ഇല്ല.
3. വായു ദ്രവ്യമാണ്.
4. എല്ലാ ലോഹങ്ങളും ഖരാവസ്ഥയിൽ സ്ഥിതി ചെയ്യുന്നു.
5. ജലം നീരാവിയാവുമ്പോൾ ഹൈഡ്രജനും ഓക്സിജനുമായി മാറുന്നു.
6. പ്രകാശവർഷം വലിയ ദൂരങ്ങളുടെ അളവാണ്.
7. ഭൂമിയും സൂര്യനും തമ്മിലുള്ള അളവാണ് പ്രകാശവർഷം.
8. സാധാരണ വർഷത്തേക്കാൾ വേഗത്തിൽ കടന്നു പോകുന്ന വർഷമാണ് പ്രകാശവർഷം.
9. പ്രകാശവർഷം സമയത്തിന്റെ അളവാണ്.
10. സൂര്യനിൽ ഊർജ്ജം ഒരിക്കലും കുറയുകയില്ല.
11. സൂര്യൻ ഒരു നക്ഷത്രമല്ല.
12. ഭൂമിയിൽ നിന്ന് നോക്കുമ്പോൾ ചന്ദ്രന്റെ ഒരു വശം തന്നെയാണ് എപ്പോഴും കാണുന്നത്.
13. ഇന്ത്യയിൽ നിന്ന് നോക്കുമ്പോൾ ചന്ദ്രന്റെ ഒരു വശവും അമേരിക്കയിൽ നിന്ന് നോക്കുമ്പോൾ മറുവശവും കാണുന്നു.
14. ചന്ദ്രൻ സ്വന്തമായി പ്രകാശമു്ട.
15. നക്ഷത്രങ്ങൾക്കെല്ലാം ഒരേവലിപ്പമാണ് ഉള്ളത്.
16. നക്ഷത്രങ്ങളുടെ തിളക്കം ഭൂമിയിൽ നിന്ന് നക്ഷത്രങ്ങളിലേക്കുള്ള അകലത്തെ മാത്രം ആശ്രയിക്കുന്നു.
17. ഭാരം കൂടിയ വസ്തുക്കൾ ജലത്തിൽ മുങ്ങുപോകുന്നു.
18. ലോഹനിർമ്മിതമായതോ ഭാരം കൂടിയതോ ആയ വസ്തുക്കൾ ജലത്തിൽ മുങ്ങിക്കിടക്കുന്നു.
19. വസ്തുക്കൾ ജലത്തിൽ പൊങ്ങിക്കിടക്കുന്നത് അവ ജലത്തേക്കാൾ ഭാരം കുറഞ്ഞതുകൊണ്ടാണ്.

20. സാമ്പ്രത കുറഞ്ഞ വസ്തുക്കൾ ജലത്തിൽ പൊങ്ങിക്കിടക്കുന്നു.
21. ഐസ് ജലത്തിൽ പൊങ്ങിക്കിടക്കാൻ കാരണം അതിനിടക്ക് വായു ഉള്ളത് കൊണ്ട്.
22. എണ്ണയും ജലവും കൂടി കലരാത്തതിനാൽ എണ്ണ പൊങ്ങിക്കിടക്കുന്നു.
23. സാമ്പ്രത കൂടുതലായതുകൊണ്ട് വസ്തുക്കൾ ജലത്തിൽ പൊങ്ങിക്കിടക്കുന്നത്.
24. ഐസിന്റെ വലിയ കട്ട ജലത്തിൽ പൊങ്ങിക്കിടക്കില്ല കാരണം അത് ഭാരം കൂടിയതാണ്.
25. വസ്തുവിന്റെ വ്യാപ്തവും മാസും പൊങ്ങിക്കിടക്കുന്നതിനെ സ്വാധീനിക്കുന്നു.
26. സമുദ്രനിരപ്പിൽ നിന്നും മുകളിലേക്ക് പോവുന്നതനുസരിച്ച് അന്തരീക്ഷമർദ്ദം കൂടുന്നു.
27. സമുദ്രത്തിന്റെ അടിവശത്ത് അനുഭവപ്പെടുന്ന മർദ്ദം വളരെ കുറവായിരിക്കും.
28. ചലനം എന്നത് തികച്ചും ആപേക്ഷികമാണ്.
29. സഞ്ചരിച്ചദൂരവും സ്ഥാനാന്തരവും ഒന്നു തന്നെയാണ്.
30. പ്രവേഗത്തിന്റെ വർദ്ധനവിനെ താരണം എന്നു പറയുന്നു.
31. വേഗതയുടെ മറ്റൊരു പേരാണ് പ്രവേഗം.
32. വസ്തുവിന്റെ വേഗതയ്ക്ക് ദിശയുമായി ബന്ധമുണ്ട്.
33. വേഗതയുടെയും പ്രവേഗത്തിന്റെയും യൂണിറ്റ് ഒന്ന് തന്നെയാണ്.
34. ഒരു വസ്തു ആകെ സഞ്ചരിച്ച ദൂരമാണ് സ്ഥാനാന്തരം.
35. യൂണിറ്റ് സമയംകൊണ്ട് വസ്തു സഞ്ചരിക്കുന്ന ദൂരമാണ് പ്രവേഗം.
36. ചലിക്കുന്ന വസ്തുക്കൾക്ക് താരണം ഉണ്ടാകാത്തവിധം നിർബന്ധമായും പ്രവേഗ വർദ്ധനവുണ്ടാകണം.
37. പ്രവേഗം വർദ്ധിക്കുന്നതനുസരിച്ച് വസ്തുവിന്റെ മാസിന് വ്യത്യാസം വരുന്നു.
38. ക്രമാവർത്തന ചലനങ്ങൾ നിശ്ചിത സമയദൈർഘ്യത്തിനുള്ളിൽ ആവർത്തിക്കപ്പെടുന്നില്ല.
39. എല്ലാ ദോലനങ്ങളും കമ്പനങ്ങളും സിമ്പിൾ ഹാർമോണിക് ആണ്.
40. മാസ് എന്നത് വസ്തുവിന്റെ ഭാരത്തിനു തുല്യമാണ്.
41. വസ്തുവിൽ അടങ്ങിയിരിക്കുന്ന ദ്രവ്യത്തിന്റെ അളവാണ് മാസ്.
42. മാസ് എന്നത് വസ്തുവിന്റെ വലിപ്പമാണ്.
43. മനുഷ്യനാൽ മാത്രം പ്രയോഗിക്കപ്പെടുന്നതാണ് ബലം.
44. പ്രവൃത്തി ചെയ്യാനുള്ള കഴിവാണ് ബലം.
45. ബലം ഒരു വസ്തുവിന്റെ ചലനാവസ്ഥയ്ക്ക് മാറ്റം വരുത്തുന്നു.
46. വസ്തുവിന്റെ ചലനത്തിനോ നിശ്ചലാവസ്ഥയ്ക്കോ മാറ്റം വരുത്തുന്ന ശക്തിയാണ് ബലം.

47. വസ്തു ചലിക്കുന്നില്ലെങ്കിൽ അതിന്മേൽ ഒരു ബലവും പ്രയോഗിക്കപ്പെടുന്നില്ല.
48. ഭൂമിയുടെ മധ്യഭാഗത്ത് ഗുരുത്വാകർഷണബലം വളരെ കൂടുതലായിരിക്കും.
49. എല്ലാ രാജ്യങ്ങളിലും ഭൂഗുരുത്വാകർഷണ തരണം തുല്യമായിരിക്കും.
50. ലോഹനിർമ്മിതവും വ്യത്യസ്ത ഭാരവും തുല്യരൂപവുമുള്ള രണ്ട് വസ്തുക്കൾ ഒരേ ഉയരത്തിൽ നിന്ന് താഴേക്ക് പതിച്ചാൽ ഭാരം കൂടിയത് ആദ്യം നിലം പതിക്കുന്നു.
51. ബഹിരാകാശത്ത് സഞ്ചാരിക്ക് ഭാരക്കുറവ് അനുഭവപ്പെടുന്നത് ഭൂഗുരുത്വബലം കുറവായതുകൊണ്ടാണ്.
52. ഗുരുത്വാകർഷണബലത്തിന് പ്രവർത്തിക്കാൻ ഒരു മാധ്യമം ആവശ്യമാണ്.
53. വായു ഇല്ലെങ്കിൽ ഗുരുത്വാകർഷണബലം പ്രവർത്തിക്കുകയില്ല.
54. പ്രവൃത്തിയും ജോലിയും ഒന്നു തന്നെയാണ്.
55. പ്രവൃത്തി നടക്കണമെങ്കിൽ ബലം പ്രയോഗിക്കപ്പെടുന്നു.
56. പ്രയോഗിക്കപ്പെടുന്ന ബലത്തിനെതിരായി പ്രവൃത്തി നടക്കാൻ സാധ്യമല്ല.
57. എവിടെ ബലം പ്രയോഗിക്കപ്പെടുന്നുവോ അവിടെ പ്രവൃത്തി നടക്കുന്നു.
58. പ്രവൃത്തി ചെയ്യാനുള്ള കഴിവിനെ ഊർജ്ജം എന്നു പറയുന്നു.
59. വിവിധ ഊർജ്ജ രൂപങ്ങൾക്ക് പരസ്പര മാറ്റം സംഭവിക്കുകയില്ല.
60. നിശ്ചലാവസ്ഥയിലുള്ള ഒരു വസ്തുവിന് ഊർജ്ജമില്ല.
61. ചലിക്കാത്ത വസ്തുവിന് സ്ഥിതികോർജ്ജമില്ല.
62. ഉയരത്തിൽ സ്ഥിതി ചെയ്യുന്ന വസ്തുവിൽ സ്ഥിതികോർജ്ജം അടങ്ങിയിട്ടുണ്ട്.
63. ഊർജ്ജവും ബലവും ഒന്നു തന്നെയാണ്.
64. പ്രകാശത്തിലെ എല്ലാ നിറങ്ങളും പ്രതിഫലിപ്പിക്കുന്ന വസ്തു കറുപ്പായി കാണുകയും എല്ലാ നിറങ്ങളും ആഗിരണം ചെയ്യുന്ന വസ്തു വെളുപ്പായി കാണുകയും ചെയ്യുന്നു.
65. ഗ്ലാസ് ട്രാൻസ്മിറ്റിൽ പകുതി മുങ്ങി നിൽക്കുന്ന ഒരു പെൻസിൽ ചെറുതായി വളഞ്ഞിരിക്കുന്നു.
66. പ്രകാശം നേർരേഖാ പാതയിൽ സഞ്ചരിക്കുന്നു.
67. സൂര്യപ്രകാശത്തിലെ എല്ലാ രശ്മികളും കാണാൻ സാധിക്കും.
68. ഏഴു വർണ്ണങ്ങൾ ചേർന്നാൽ മാത്രമേ ധവളപ്രകാശം ലഭിക്കുകയുള്ളൂ.
69. സമുദ്രവും തടാകങ്ങളും നീലനിറത്തിൽ കാണുന്നത് ആകാശത്തെ പ്രതിഫലിപ്പിക്കുന്നതുകൊണ്ടാണ്.
70. പ്രകാശത്തിൽ താപഫലം ഉണ്ടാക്കാത്ത രശ്മികൾ ഇല്ല.
71. ഇലക്ട്രിക് ബൾബിലെ പ്രകാശം മെഴുകുതിരിയുടെ പ്രകാശത്തേക്കാൾ വേഗതയിൽ സഞ്ചരിക്കും.
72. ലെൻസിലൂടെ കടന്നുപോകുന്ന പ്രകാശ രശ്മി ലെൻസിന്റെ ഫോക്കസ്സിൽ കേന്ദ്രീകരിക്കുന്നു.

73. ശബ്ദത്തിന് പ്രവൃത്തി ചെയ്യാനാവും.
74. ശബ്ദം നേർരേഖയിൽ സഞ്ചരിക്കുന്നു.
75. വസ്തുക്കളുടെ കമ്പനം കൂടാതെയും ശബ്ദം ഉണ്ടാകാം.
76. വായുവിൽ ശബ്ദം വസ്തുക്കളിലൂടെ സഞ്ചരിക്കുന്നതിനേക്കാൾ വേഗതയിൽ സഞ്ചരിക്കുന്നു.
77. ശബ്ദത്തിന് സഞ്ചരിക്കാൻ മാധ്യമം ആവശ്യമില്ല.
78. എല്ലാ ശബ്ദങ്ങളും ശ്രവണബോധമുണ്ടാകുന്നു.
79. ആവൃത്തി വർദ്ധിക്കുമ്പോൾ ശബ്ദത്തിന്റെ തരംഗദൈർഘ്യം കുറയുന്നു.
80. നമുക്ക് കേൾക്കാൻ സാധിക്കാത്ത ശബ്ദതരംഗങ്ങളില്ല.
81. 20 ഹെർട്സിൽ കൂടുതൽ ആവൃത്തിയുള്ള ശബ്ദതരംഗങ്ങൾ ശ്രവണയോഗ്യമാണ്.
82. കാന്തത്തിനു മാത്രമേ കാന്തികമണ്ഡലം നിർമ്മിക്കാൻ സാധിക്കുകയുള്ളൂ.
83. വൈദ്യുത പ്രവാഹത്തിന് കാന്തികമണ്ഡലം നിർമ്മിക്കാൻ സാധിക്കും.
84. വലിയ കാന്തങ്ങൾ ചെറിയവയേക്കാൾ ശക്തിയുള്ളവയായിരിക്കും.
85. ഏറ്റവും നല്ല വൈദ്യുതി ചാലകം ഇരുമ്പാണ്.
86. ശുദ്ധജലത്തിലൂടെ വൈദ്യുതി വളരെ പെട്ടെന്ന് കടന്ന് പോകും.
87. ബാറ്ററികൾ വൈദ്യുതി ശേഖരിച്ച് വച്ചിരിക്കുന്നു.
88. ചാലകത്തിന്റെ പ്രതിരോധം ഉയർത്തുകയോ താപനില കുറയ്ക്കുകയോ ചെയ്യുമ്പോൾ പ്രതിരോധ ഗുണാങ്കം (റസിസ്റ്റിവിറ്റി) കുറയുന്നു.
89. രാജ്യത്തിലെ ബിന്ദുക്കൾ തമ്മിൽ പൊട്ടൻഷ്യൽ വ്യത്യാസം ഇല്ലെങ്കിൽ അവയ്ക്കിടയിൽ വൈദ്യുതി പ്രവാഹം സാധ്യമല്ല.
90. പൊട്ടൻഷ്യൽ വ്യത്യാസത്തിന്റെ യൂണിറ്റ് വോൾട്ട് ആണ്.
91. പൊട്ടൻഷ്യൽ വ്യത്യാസം വർദ്ധിക്കുമ്പോൾ വൈദ്യുത പ്രവാഹവും വർദ്ധിക്കുന്നു.
92. വൈദ്യുത പ്രവാഹത്തിന്റെ യൂണിറ്റാണ് ആമ്പിയർ.
93. ഘർഷണം മൂലമാണ് സ്ഥിതവൈദ്യുതി ഉണ്ടാവുന്നത്.
94. വസ്തുക്കൾ തമ്മിൽ ഉരസുമ്പോൾ ചാർജ്ജ് കൈമാറ്റം ചെയ്യപ്പെടുന്നതിനാൽ സ്ഥിത വൈദ്യുതി ഉണ്ടാകുന്നു.
95. ഐസുകട്ട ചൂടാക്കിയ ഇരുമ്പുദണ്ഡുമായി സ്പർശനത്തിൽ വരുമ്പോൾ ഇരുമ്പ് ദണ്ഡിന് മാത്രമാണ് താപവ്യതിയാനം സംഭവിക്കുന്നത്.
96. താപധാരിത എന്നാൽ  $1^{\circ}\text{C}$  ഉയർത്താനാവശ്യമായ കഴിവാണ്.
97. താപവും താപനിലയും ഒന്നുതന്നെയാണ്.
98. ഐസുകട്ട ഉറുകി ജലമായി മാറുമ്പോൾ അതിന്റെ വ്യാപ്തം വർദ്ധിക്കുന്നു.

**UNIVERSITY OF CALICUT  
DEPARTMENT OF EDUCATION**

**TEST OF CONCEPT ATTAINMENT IN PHYSICS (TCAP)  
LONGER VERSION (DRAFT)**

**Dr. K. Abdul Gafoor**  
Associate Professor

**Akhilesh, P.T.**  
Research Scholar

---

**Instruction:**

Read the following statements carefully. Put a '✓' mark for your answer in the response sheet in the appropriate column against the serial number of each statement. The data collected from you will be kept confidential and used for research purpose only.

---

1. Gases are not matter, because they are invisible
2. Gases are mass less
3. Air is matter
4. Metals can occur in solid state only
5. On evaporation Water gets converted into oxygen and hydrogen
6. Light year is measure of big distances
7. Distance between sun and earth is light year
8. Light year is the year which passes speedy than normal year
9. Light year is the measure of time.
10. Energy of sun never ceases
11. Sun is not a star
12. The same side of moon is always seeing from earth
13. We see one face of moon from India and the other from America
14. Moon has its own light
15. All stars have same size
16. Brightness of stars depends only on the distance from earth
17. Heavy objects sink in water.
18. Objects with metal or heavier will sink in water.
19. Some substances floats in water since they are lighter than water
20. Low density substances float in water

21. The reason behind floating of ice is the presence of air inside
22. Water and oil are immiscible so oil floats over water
23. Substance should contain air to float
24. Due to its heaviness a big cube ice can't float.
25. Density and volume influences floating of bodies.
26. Atmospheric pressure increases with altitude
27. Pressure in sea bed will be too less than surface
28. Motion is relative
29. Displacement and distance are same always
30. Increase in velocity is termed as acceleration
31. Velocity is the other name of speed.
32. Speed of an object is related to direction
33. Unit of speed and acceleration are same
34. Displacement is the total distance travelled by the object
35. Velocity is the distance covered in unit time
36. To have acceleration to a moving body its velocity should be increased
37. Periodic motion is not the repeated motion in fixed interval
38. All vibrations and will be simple harmonic
39. When velocity increases the mass of substance will change
40. Mass is equivalent to weight of substance
41. Mass is the amount of matter in substance
42. Mass denotes size of the object
43. Force is that which can only apply by men
44. Force is the capacity to do work
45. Motion of an object can only be changed by force
46. Force is the entity which changes the state of motion or rest of an object
47. If an object is at rest there is no force acting on it
48. Gravity is maximum at the centre of earth
49. Acceleration due to gravity is same everywhere
50. Two metallic objects with different size is allowed to fall from same height  
the heavier will reach first
51. Astronaut feel weightlessness due to low gravity
52. Gravity needs a medium to come in action
53. Without air(medium) gravity cannot act through

54. Work and labor are same
55. Force is essential to do work
56. Work never take place against the applied force
57. Wherever force is acting work will be done there
58. Energy is the capacity to do work
59. Different energy forms cannot be transformed to one another
60. Object at rest do not possesses any energy
61. Stationary object does not have potential energy
62. An object placed at a height possesses potential energy
63. Energy and force are same
64. The surface which absorbs all colors of visible light appears in black where as the surface which reflects all the colors is seen in white
65. Pencil partially dipped in water will be seen slightly distorted.
66. Light rays travel in straight line only
67. All rays in sunlight are visible
68. Seven colors of visible spectrum forms white light
69. Lakes and sea are found in blue color since they reflects sky
70. All rays of sunlight exhibit heating effect
71. Light rays from an electric bulb travels faster than candle light
72. Light ray travelling through a lens focuses at its centre.
73. Sound can do work
74. Sound waves travel in straight line
75. Object can make sound without vibration
76. Sound in air travels faster than that in solid
77. Sound needs no medium to travel
78. All kinds of sounds make the sense of sound in brain.
79. When frequency increased wave length of sound wave is increased.
80. Sound wave of frequency more than 20Hzare audible
81. All sounds are audible to human ear
82. Only a magnet can produce magnetic field
83. Electricity can produce magnetic field
84. Smaller magnets are stronger than bigger ones
85. Iron is the best conductor of electricity in nature.
86. Pure water is a good conductor of electricity

87. As length of a conductor increases resistivity increases or temperature is decreases resistivity is decreases
88. If there is no potential difference between two points no current will flow
89. Unit of potential difference is volt.
90. Flow of electricity increases as potential difference increases.
91. Ampere is the unit of electricity flow in a circuit.
92. Batteries store current.
93. Static electricity is produced due to friction.
94. When materials are rubbed, electricity is produced due to exchange of charge
95. When an ice cube and heated iron is come in contact, heat difference happen to iron only
96. Heat capacity is the capacity to increase in temperature to one degree
97. Heat and temperature are the same
98. When ice is converted to water its volume increases.

**TEST OF CONCEPT ATTAINMENT IN PHYSICS (TCAP)  
LONGER VERSION (DRAFT)**

**RESPONSE SHEET**

Sl. No.	Yes	No
1.		
2.		
3.		
4.		
5.		
6.		
7.		
8.		
9.		
10.		
11.		
12.		
13.		
14.		
15.		
16.		
17.		
18.		
19.		
20.		
21.		
22.		
23.		
24.		
25.		
26.		
27.		
28.		
29.		
30.		
31.		
32.		
33.		

Sl. No.	Yes	No
34.		
35.		
36.		
37.		
38.		
39.		
40.		
41.		
42.		
43.		
44.		
45.		
46.		
47.		
48.		
49.		
50.		
51.		
52.		
53.		
54.		
55.		
56.		
57.		
58.		
59.		
60.		
61.		
62.		
63.		
64.		
65.		
66.		

Sl. No.	Yes	No
67.		
68.		
69.		
70.		
71.		
72.		
73.		
74.		
75.		
76.		
77.		
78.		
79.		
80.		
81.		
82.		
83.		
84.		
85.		
86.		
87.		
88.		
89.		
90.		
91.		
92.		
93.		
94.		
95.		
96.		
97.		
98.		

UNIVERSITY OF CALICUT  
DEPARTMENT OF EDUCATION

TEST OF CONCEPT ATTAINMENT IN PHYSICS (TCAP)  
LONGER VERSION (FINAL)

**Dr. K. Abdul Gafoor**  
Associate Professor

**Akhilesh, P.T.**  
Research Scholar

---

1. വാതകങ്ങൾ പദാർത്ഥങ്ങളല്ല കാരണം അത് അദൃശ്യമാണ്.
2. വാതകങ്ങൾക്ക് പിണ്ഡം ഇല്ല.
3. വായു ദ്രവ്യമാണ്.
4. എല്ലാ ലോഹങ്ങളും ഖരാവസ്ഥയിൽ സ്ഥിതി ചെയ്യുന്നു.
5. ജലം നീരാവിയാവുമ്പോൾ ഹൈഡ്രജനും ഓക്സിജനുമായി മാറുന്നു.
6. സൂര്യനിൽ ഊർജ്ജം ഒരിക്കലും കുറയുകയില്ല.
7. സൂര്യൻ ഒരു നക്ഷത്രമല്ല.
8. ഭൂമിയിൽ നിന്ന് നോക്കുമ്പോൾ ചന്ദ്രന്റെ ഒരു വശം തന്നെയാണ് എപ്പോഴും കാണുന്നത്.
9. ഇന്ത്യയിൽ നിന്ന് നോക്കുമ്പോൾ ചന്ദ്രന്റെ ഒരു വശവും അമേരിക്കയിൽ നിന്ന് നോക്കുമ്പോൾ മറുവശവും കാണുന്നു.
10. ചന്ദ്രൻ സ്വന്തമായി പ്രകാശമു്ട.
11. നക്ഷത്രങ്ങൾക്കെല്ലാം ഒരേവലിപ്പമാണ് ഉള്ളത്.
12. നക്ഷത്രങ്ങളുടെ തിളക്കം ഭൂമിയിൽ നിന്ന് നക്ഷത്രങ്ങളിലേക്കുള്ള അകലത്തെ മാത്രം ആശ്രയിക്കുന്നു.
13. വസ്തുക്കൾ ജലത്തിൽ പൊങ്ങിക്കിടക്കുന്നത് അവ ജലത്തേക്കാൾ ഭാരം കുറഞ്ഞതുകൊ ടാണ്.
14. സാന്ദ്രത കുറഞ്ഞ വസ്തുക്കൾ ജലത്തിൽ പൊങ്ങിക്കിടക്കുന്നു.
15. ഐസ് ജലത്തിൽ പൊങ്ങിക്കിടക്കാൻ കാരണം അതിനിടക്ക് വായു ഉള്ളത് കൊ ടാണ്.
16. എണ്ണയും ജലവും കൂടി കലരാത്തതിനാൽ എണ്ണ പൊങ്ങിക്കിടക്കുന്നു.
17. സാന്ദ്രത കൂടുതലായതുകൊ ട് വസ്തുക്കൾ ജലത്തിൽ പൊങ്ങി കിടക്കുന്നത്.
18. ഐസിന്റെ വലിയ കട്ട ജലത്തിൽ പൊങ്ങിക്കിടക്കില്ല കാരണം അത് ഭാരം കൂടിയതാണ്.
19. വസ്തുവിന്റെ വ്യാപ്തവും മാസും പൊങ്ങിക്കിടക്കുന്നതിനെ സ്വാധീനിക്കുന്നു.
20. സമുദ്രനിരപ്പിൽ നിന്നും മുകളിലേക്ക് പോവുന്നതനുസരിച്ച് അന്തരീഷമർദ്ദം കൂടുന്നു.

21. സമുദ്രത്തിന്റെ അടിവശത്ത് അനുഭവപ്പെടുന്ന മർദ്ദം വളരെ കുറവായിരിക്കും.
22. ചലനം എന്നത് തികച്ചും ആപേക്ഷികമാണ്.
23. സഞ്ചരിച്ചദൂരവും സ്ഥാനാന്തരവും ഒന്നു തന്നെയാണ്.
24. പ്രവേഗത്തിന്റെ വർദ്ധനവിനെ താരണം എന്നു പറയുന്നു.
25. വേഗതയുടെ മറ്റൊരു പേരാണ് പ്രവേഗം.
26. വസ്തുവിന്റെ വേഗതയ്ക്ക് ദിശയുമായി ബന്ധമുണ്ട്.
27. വേഗതയുടെയും പ്രവേഗത്തിന്റെയും യൂണിറ്റ് ഒന്ന് തന്നെയാണ്.
28. ഒരു വസ്തു ആകെ സഞ്ചരിച്ച ദൂരമാണ് സ്ഥാനാന്തരം.
29. യൂണിറ്റ് സമയംകൊണ്ട് വസ്തു സഞ്ചരിക്കുന്ന ദൂരമാണ് പ്രവേഗം.
30. ചലിക്കുന്ന വസ്തുക്കൾക്ക് താരണം ഉണ്ടാവണമെങ്കിൽ നിർബന്ധമായും പ്രവേഗ വർദ്ധനവുണ്ടാവണം.
31. പ്രവേഗം വർദ്ധിക്കുന്നതനുസരിച്ച് വസ്തുവിന്റെ മാസിന് വ്യത്യാസം വരുന്നു.
32. മാസ് എന്നത് വസ്തുവിന്റെ ഭാരത്തിനു തുല്യമാണ്.
33. വസ്തുവിൽ അടങ്ങിയിരിക്കുന്ന ദ്രവ്യത്തിന്റെ അളവാണ് മാസ്.
34. മാസ് എന്നത് വസ്തുവിന്റെ വലിപ്പമാണ്.
35. മനുഷ്യനാൽ മാത്രം പ്രയോഗിക്കപ്പെടുന്നതാണ് ബലം.
36. പ്രവൃത്തി ചെയ്യാനുള്ള കഴിവാണ് ബലം.
37. ബലം ഒരു വസ്തുവിന്റെ ചലനാവസ്ഥയ്ക്ക് മാറ്റം വരുത്തുന്നു.
38. വസ്തുവിന്റെ ചലനത്തിനോ നിശ്ചലാവസ്ഥക്കോ മാറ്റം വരുത്തുന്ന ശക്തിയാണ് ബലം.
39. വസ്തു ചലിക്കുന്നില്ലെങ്കിൽ അതിന്മേൽ ഒരു ബലവും പ്രയോഗിക്കപ്പെടുന്നില്ല.
40. ഭൂമിയുടെ മധ്യഭാഗത്ത് ഗുരുത്വാകർഷണബലം വളരെ കൂടുതലായിരിക്കും.
41. എല്ലാ രാജ്യങ്ങളിലും ഭൂഗുരുത്വാകർഷണ താരണം തുല്യമായിരിക്കും.
42. ലോഹനിർമ്മിതവും വ്യത്യസ്ത ഭാരവും തുല്യരൂപവുമുള്ള രണ്ട് വസ്തുക്കൾ ഒരേ ഉയരത്തിൽ നിന്ന് താഴേക്ക് പതിച്ചാൽ ഭാരം കൂടിയത് ആദ്യം നിലം പതിക്കുന്നു.
43. ബഹിരാകാശത്ത് സഞ്ചാരിക്ക് ഭാരക്കുറവ് അനുഭവപ്പെടുന്നത് ഭൂഗുരുത്വബലം കുറവായതുകൊണ്ടാണ്.
44. ഗുരുത്വാകർഷണബലത്തിന് പ്രവർത്തിക്കാൻ ഒരു മാധ്യമം ആവശ്യമാണ്.
45. വായു ഇല്ലെങ്കിൽ ഗുരുത്വാകർഷണബലം പ്രവർത്തിക്കുകയില്ല.
46. പ്രവൃത്തിയും ജോലിയും ഒന്നു തന്നെയാണ്.
47. പ്രവൃത്തി നടക്കണമെങ്കിൽ ബലം പ്രയോഗിക്കപ്പെടുന്നു.
48. പ്രയോഗിക്കപ്പെടുന്ന ബലത്തിനെതിരായി പ്രവൃത്തി നടക്കാൻ സാധ്യമല്ല.
49. എവിടെ ബലം പ്രയോഗിക്കപ്പെടുന്നുോ അവിടെ പ്രവൃത്തി നടക്കുന്നു.
50. പ്രവൃത്തി ചെയ്യാനുള്ള കഴിവിനെ ഊർജ്ജം എന്നു പറയുന്നു.
51. വിവിധ ഊർജ്ജ രൂപങ്ങൾക്ക് പരസ്പര മാറ്റം സംഭവിക്കുകയില്ല.

52. നിശ്ചലാവസ്ഥയിലുള്ള ഒരു വസ്തുവിന് ഊർജ്ജമില്ല.
53. ചലിക്കാത്ത വസ്തുവിന് സ്ഥിതികോർജ്ജമില്ല.
54. ഉയരത്തിൽ സ്ഥിതി ചെയ്യുന്ന വസ്തുവിൽ സ്ഥിതികോർജ്ജം അടങ്ങിയിട്ടുണ്ട്.
55. ഊർജ്ജവും ബലവും ഒന്നു തന്നെയാണ്.
56. പ്രകാശത്തിലെ എല്ലാ നിറങ്ങളും പ്രതിഫലിപ്പിക്കുന്ന വസ്തു കറുപ്പായി കാണുകയും എല്ലാ നിറങ്ങളും ആഗിരണം ചെയ്യുന്ന വസ്തു വെളുപ്പായി കാണുകയും ചെയ്യുന്നു.
57. ഗ്ലാസ് ട്രാൻസ്മിറ്റ് പകുതി മുങ്ങി നിൽക്കുന്ന ഒരു പെൻസിൽ ചെറുതായി വളഞ്ഞിരിക്കുന്നു.
58. പ്രകാശം നേർരേഖാ പാതയിൽ സഞ്ചരിക്കുന്നു.
59. സൂര്യപ്രകാശത്തിലെ എല്ലാ രശ്മികളും കാണാൻ സാധിക്കും.
60. ഏഴു വർണ്ണങ്ങൾ ചേർന്നാൽ മാത്രമേ ധവളപ്രകാശം ലഭിക്കുകയുള്ളൂ.
61. സമുദ്രവും തടാകങ്ങളും നീലനിറത്തിൽ കാണുന്നത് ആകാശത്തെ പ്രതിഫലിപ്പിക്കുന്നതുകൊണ്ടാണ്.
62. പ്രകാശത്തിൽ താപഫലം ഉണ്ടാക്കാത്ത രശ്മികൾ ഇല്ല.
63. ഇലക്ട്രിക് ബൾബിലെ പ്രകാശം മെഴുകുതിരിയുടെ പ്രകാശത്തേക്കാൾ വേഗതയിൽ സഞ്ചരിക്കും.
64. ലെൻസിലൂടെ കടന്നുപോകുന്ന പ്രകാശ രശ്മി ലെൻസിന്റെ ഫോക്കസ്സിൽ കേന്ദ്രീകരിക്കുന്നു.
65. ശബ്ദത്തിന് പ്രവൃത്തി ചെയ്യാനാവും.
66. ശബ്ദം നേർരേഖയിൽ സഞ്ചരിക്കുന്നു.
67. വസ്തുക്കളുടെ കമ്പനം കൂടാതെയും ശബ്ദം ഉണ്ടാക്കാം.
68. വായുവിൽ ശബ്ദം വസ്തുക്കളിലൂടെ സഞ്ചരിക്കുന്നതിനേക്കാൾ വേഗതയിൽ സഞ്ചരിക്കുന്നു.
69. ശബ്ദത്തിന് സഞ്ചരിക്കാൻ മാധ്യമം ആവശ്യമില്ല.
70. എല്ലാ ശബ്ദങ്ങളും ശ്രവണബോധമുണ്ടാക്കുന്നു.
71. ആവൃത്തി വർദ്ധിക്കുമ്പോൾ ശബ്ദത്തിന്റെ തരംഗദൈർഘ്യം കുറയുന്നു.
72. നമുക്ക് കേൾക്കാൻ സാധിക്കാത്ത ശബ്ദതരംഗങ്ങളില്ല.
73. കാന്തത്തിനു മാത്രമേ കാന്തികമണ്ഡലം നിർമ്മിക്കാൻ സാധിക്കുകയുള്ളൂ.
74. വൈദ്യുത പ്രവാഹത്തിന് കാന്തികമണ്ഡലം നിർമ്മിക്കാൻ സാധിക്കും.
75. വലിയ കാന്തങ്ങൾ ചെറിയവയേക്കാൾ ശക്തിയുള്ളവയായിരിക്കും.
76. ഏറ്റവും നല്ല വൈദ്യുതി ചാലകം ഇരുമ്പാണ്.
77. ശുദ്ധജലത്തിലൂടെ വൈദ്യുതി വളരെ പെട്ടെന്ന് കടന്ന് പോകും.
78. ബാറ്ററികൾ വൈദ്യുതി ശേഖരിച്ച് വച്ചിരിക്കുന്നു.
79. ഘർഷണം മൂലമാണ് സ്ഥിതവൈദ്യുതി ഉണ്ടാവുന്നത്.
80. വസ്തുക്കൾ തമ്മിൽ ഉരസുമ്പോൾ ചാർജ്ജ് കൈമാറ്റം ചെയ്യപ്പെടുന്നതിനാൽ സ്ഥിത വൈദ്യുതി ഉണ്ടാകുന്നു.

**UNIVERSITY OF CALICUT  
DEPARTMENT OF EDUCATION**

**TEST OF CONCEPT ATTAINMENT IN PHYSICS (TCAP) –  
LONGER VERSION (FINAL)**

**Dr. K. Abdul Gafoor**  
Associate Professor

**Akhilesh, P.T.**  
Research Scholar

---

1. Gases are not matter, because they are invisible
2. Gases are mass less
3. Air is matter
4. Metals can occur in solid state only
5. On evaporation Water gets converted into oxygen and hydrogen
6. Energy of sun never ceases
7. Sun is not a star
8. The same side of moon is always seeing from earth
9. We see one face of moon from India and the other from America
10. Moon has its own light
11. All stars have same size
12. Brightness of stars depends only on the distance from earth
13. Some substances floats in water since they are lighter than water
14. Low density substances float in water
15. The reason behind floating of ice is the presence of air inside
16. Water and oil are immiscible so oil floats over water
17. Substance should contain air to float
18. Due to its heaviness a big cube ice can't float.
19. Density and volume influences floating of bodies.
20. Atmospheric pressure increases with altitude
21. Pressure in sea bed will be too less than surface
22. Motion is relative
23. Displacement and distance are same always
24. Increase in velocity is termed as acceleration
25. Velocity is the other name of speed.
26. speed of an object is related to direction

27. Unit of speed and acceleration are same
28. Displacement is the total distance travelled by the object
29. Velocity is the distance covered in unit time
30. To have acceleration to a moving body its velocity should be increased
31. When velocity increases the mass of substance will change
32. Mass is equivalent to weight of substance
33. Mass is the amount of matter in substance
34. Mass denotes size of the object
35. Force is that which can only apply by men
36. Force is the capacity to do work
37. Motion of an object can only be changed by force
38. Force is the entity which changes the state of motion or rest of an object
39. If an object is at rest there is no force acting on it
40. Gravity is maximum at the centre of earth
41. Acceleration due to gravity is same everywhere
42. Two metallic objects with different size is allowed to fall from same height the heavier will reach first
43. Astronaut feel weightlessness due to low gravity
44. Gravity needs a medium to come in action
45. Without air(medium) gravity cannot act through
46. Work and labor are same
47. Force is essential to do work
48. Work never take place against the applied force
49. Wherever force is acting work will be done there
50. Energy is the capacity to do work
51. Different energy forms cannot be transformed to one another
52. Object at rest do not possesses any energy
53. Stationary object does not have potential energy
54. An object placed at a height possesses potential energy
55. Energy and force are same
56. The surface which absorbs all colors of visible light appears in black where as the surface which reflects all the colors is seen in white
57. Pencil partially dipped in water will be seen slightly distorted.
58. Light rays travel in straight line only

59. All rays in sunlight are visible
60. Seven colors of visible spectrum forms white light
61. Lakes and sea are found in blue color since they reflect sky
62. All rays of sunlight exhibit heating effect
63. Light rays from an electric bulb travel faster than candle light
64. Light ray travelling through a lens focuses at its centre.
65. Sound can do work
66. Sound waves travel in straight line
67. Object can make sound without vibration
68. Sound in air travels faster than that in solid
69. Sound needs no medium to travel
70. All kinds of sounds make the sense of sound in brain.
71. Sound waves of frequency more than 20 Hz are audible
72. All sounds are audible to human ear
73. Only a magnet can produce magnetic field
74. Electricity can produce magnetic field
75. Big magnets are stronger than smaller ones
76. Iron is the best conductor of electricity in nature.
77. Pure water is a good conductor of electricity.
78. In battery, electricity is kept stored.
79. Static electricity is formed due to friction.
80. When materials are rubbed, electricity is produced due to exchange of charge .

**TEST OF CONCEPT ATTAINMENT IN PHYSICS (TCAP) –  
LONGER VERSION (FINAL)**

**RESPONSE SHEET**

Sl. No.	Yes	No
1.		
2.		
3.		
4.		
5.		
6.		
7.		
8.		
9.		
10.		
11.		
12.		
13.		
14.		
15.		
16.		
17.		
18.		
19.		
20.		
21.		
22.		
23.		
24.		
25.		
26.		
27.		

Sl. No.	Yes	No
28.		
29.		
30.		
31.		
32.		
33.		
34.		
35.		
36.		
37.		
38.		
39.		
40.		
41.		
42.		
43.		
44.		
45.		
46.		
47.		
48.		
49.		
50.		
51.		
52.		
53.		
54.		

Sl. No.	Yes	No
55.		
56.		
57.		
58.		
59.		
60.		
61.		
62.		
63.		
64.		
65.		
66.		
67.		
68.		
69.		
70.		
71.		
72.		
73.		
74.		
75.		
76.		
77.		
78.		
79.		
80.		

UNIVERSITY OF CALICUT  
DEPARTMENT OF EDUCATION

TEST OF CONCEPT ATTAINMENT IN PHYSICS (TCAP) –  
ABRIDGED PARALLEL VERSION (PRE-TEST)

Dr. K. Abdul Gafoor  
Associate Professor

Akhilesh, P.T.  
Research Scholar

1. അപവർത്തനം ജലത്തിൽ മാത്രം ദൃശ്യമാകുന്ന പ്രകാശ പ്രതിഭാസമാണ്.
2. സ്രോതസ്സിന് അനുസൃതമായി പ്രസരിക്കുന്ന പ്രകാശത്തിന് വ്യത്യസ്ത വേഗതയാ യിരിക്കും.
3. പ്രകാശത്തിന് കടന്ന് പോകാൻ മാധ്യമത്തിന്റെ ആവശ്യമില്ല.
4. പ്രകാശത്തിന്റെ ഘടകവർണ്ണങ്ങൾ ഒന്നിച്ച് ചേരുമ്പോൾ കറുപ്പ് നിറം ലഭിക്കുന്നു.
5. ആകാശനീലിമയ്ക്ക് കാരണം പ്രകാശത്തിന്റെ വിസരണം എന്ന സ്വഭാവമാണ്
6. എല്ലാ നിറങ്ങളേയും പ്രതിഫലിപ്പിക്കുന്ന പ്രതലം വെളുപ്പ് നിറത്തിൽ കാണപ്പെടു ന്നു.
7. അപകേന്ദ്രബലത്തിന്റെ ദിശ ഭ്രമണകേന്ദ്രത്തിലേക്കായിരിക്കും.
8. അപകേന്ദ്രബലവും അഭികേന്ദ്രബലവും തുല്യവും വ്യത്യസ്ത ദിശയിൽ പ്രവർത്തി ക്കുന്നവയുമാണ്.
9. പൊതുവെ എല്ലാ സന്ദർഭങ്ങളിലും ദൂരവും സ്ഥാനാന്തരവും തുല്യമായി കാണപ്പെ ടുന്നു.
10. ഒരു വസ്തുവിന്റെ സ്ഥിരാവസ്ഥയിൽ നിന്നുള്ള മാറ്റത്തിന്റെ കാരണമാണ് ബലം.
11. ഒരേ അവസ്ഥയിൽ തുടരുവാനുള്ള വസ്തുക്കളുടെ പ്രവണതയാണ് ജഡത്വം എന്ന് പറയുന്നത്.
12. വസ്തുക്കളുടെ ജഡത്വം അവയുടെ പിണ്ഡത്തിന് വിപരീതാനുപാത്തിലായിരിക്കും.
13. ഒരു വസ്തുവിന്റെ സ്ഥിരാവസ്ഥയ്ക്ക് മാറ്റം വരുത്തുവാൻ ബാഹ്യബലത്തിന് മാത്രമേ സാധിക്കയുള്ളൂ.
14. ഘർഷണവും, ശ്യാനതയും (Viscosity) ഏതൊരു ചലനത്തിന്റെയും എതിർദിശ യിൽ പ്രവർത്തിക്കുന്ന ബലങ്ങളാണ്.
15. ആക്കവും ബലവും പരസ്പര പൂരകങ്ങളാണ്.
16. വളരെ വലിയ ബലം ഒരു ചെറിയ വസ്തുവിൽ വളരെ ചെറിയ സമയത്തേക്ക് പ്രവർത്തിക്കുമ്പോൾ അതിനു വാക്യം ആഘാതം തുല്യമായിരിക്കും.
17. പ്രവർത്തനമില്ലെങ്കിലും പ്രതി പ്രവർത്തനമു വാ.
18. റോക്കറ്റുകളുടെ പ്രവർത്തനത്തിനാധാരം ന്യൂട്ടന്റെ ര ാം ചലന നിയമമാണ്.
19. ഒരു വ്യൂഹത്തിന്റെ ആകെ ആക്കം എല്ലായാപ്പോഴും സ്ഥിരമായിരിക്കും.

20. ജലാശയത്തിന്റെ ആഴം കൂടുമ്പോൾ അടിത്തട്ടിൽ ദ്രാവകമർദ്ദം കുറയുന്നു.
21. മുങ്ങിയിരിക്കുന്ന വസ്തുവിന്റെ മുകൾ ദിശയിലേക്ക് ബലം പ്രയോഗിക്കാൻ ദ്രാവകങ്ങൾക്ക് സാധ്യമല്ല.
22. ദ്രാവകങ്ങൾ പാത്രത്തിന്റെ എല്ലാം വശങ്ങളിലേക്കും മർദ്ദം പ്രയോഗിക്കുന്നു.
23. ദ്രാവകത്തിന്റെ ഏതെങ്കിലുമൊരു മേഖലയിൽ അനുഭവപ്പെടുന്ന മർദ്ദം പൂർണ്ണമായും ദ്രാവകത്തിലേക്ക് വ്യാപിക്കുന്നു.
24. ശുദ്ധജലം നല്ലൊരു വൈദ്യുത ചാലകമാണ്.
25. ഭൂമിയിൽ അർദ്ധചാലകങ്ങൾ സുലഭമാണ്.
26. മന്ദഗതിയിൽ ചലിക്കുന്ന വൈദ്യുത ചാർജ്ജുകൾ വൈദ്യുത പ്രവാഹം ഉണ്ടാക്കുന്നില്ല.
27. വൈദ്യുതി ശേഖരിച്ചുവയ്ക്കുന്ന സംവിധാനമാണ് ബാറ്ററികൾ.
28. കാന്തികധ്രുവങ്ങളെ വിഭജിക്കാൻ സാധ്യമല്ല.
29. സ്വതന്ത്രമായി തുങ്ങിയാടുന്ന ബാർമാഗ്നറ്റ് തെക്ക് വടക്ക് ദിശയിൽ നിശ്ചലമായി നിൽക്കും.
30. ബാർ മാഗ്നറ്റിന്റെ മധ്യഭാഗത്ത് കാന്തിക ബലരേഖകൾ തിങ്ങിനിറഞ്ഞ് കാണപ്പെടുന്നു.
31. കാന്തിക മണ്ഡലത്തിൽ ബലരേഖകൾ കൂടി പിണഞ്ഞ് കാണപ്പെടുന്നു.
32. വൈദ്യുതപ്രവാഹത്തിന്റെ ഫലമായി ലോഹങ്ങൾ കാന്തസ്വഭാവം പ്രകടിപ്പിക്കുന്നു.
33. വൈദ്യുതി കാന്തികത മൂലം ലഭിക്കുന്നവ സ്ഥിരകാന്തങ്ങളാണ്.
34. പ്രകൃതിജന്യകാന്തങ്ങൾ ലഭ്യമാണ്.
35. ശബ്ദ തരംഗങ്ങൾക്ക് സഞ്ചരിക്കാൻ മാധ്യമത്തിന്റെ ആവശ്യമില്ല.
36. ശബ്ദം ഒരു ഊർജ്ജരൂപമാണ്.
37. ശബ്ദം ഖരപദാർത്ഥങ്ങളിലൂടെ താരതമ്യേന വേഗത്തിൽ സഞ്ചരിക്കുന്നു.
38. ശബ്ദതരംഗങ്ങൾ അനുദൈർഘ്യതരംഗങ്ങളാണ്.
39. വസ്തുക്കൾ ജലത്തിൽ പൊങ്ങിനിൽക്കുന്നത് അതിന്റെ ഭാരത്തെ മാത്രം ആശ്രയിച്ചാണ്.
40. സാന്ദ്രത കുടിയ വസ്തുക്കൾ ജലത്തിൽ പൊങ്ങി കിടക്കുന്നു.

**UNIVERSITY OF CALICUT  
DEPARTMENT OF EDUCATION**

**TEST OF CONCEPT ATTAINMENT IN PHYSICS (TCAP)  
ABRIDGED PARALLEL VERSION (PRE-TEST)**

**Dr. K. Abdul Gafoor**  
Associate Professor

**Akhilesh, P.T.**  
Research Scholar

---

**Instruction:**

Read the following statements carefully. Put a '✓' mark for your answer in the response sheet in the appropriate column against the serial number of each statement. The data collected from you will be kept confidential and used for research purpose only.

---

1. The phenomenon of refraction of light is visible in water only.
2. The velocity of light will be different according to the source of propagation.
3. Light do not needs medium to travel.
4. Composite colours together forms black colour.
5. Blueness of sky is due to scattering of light.
6. The plane reflects all colours of light appears in white.
7. Centrifugal force acts towards the centre of rotation.
8. Centrifugal force and centripetal force are equal and acts in opposite direction.
9. In almost all cases displacement is equal to distance.
10. Force is the reason for change of state of an object.
11. Tendency to continue in a state is known as inertia.
12. Inertia of an object is inversely proportional to its mass.
13. An external force can only make changes in the state of an object.
14. Friction and viscosity acts opposite to the direction of motion.
15. Momentum and force are complementary to each other.
16. The impact suffered by a small object for a very large force to a small time interval is negligible.

17. Reaction can be happen without action.
18. Principle of rocket is Newton's Second Law of Motion.
19. The momentum of a system remains same always.
20. Liquid pressure decreases as the depth of pool increases.
21. Liquid cannot exert upwards pressure on an immersed object.
22. Liquid exerts pressure to all sides of the container.
23. Pressure applied on any side of a liquid dissipates to every part.
24. Pure water is a good conductor.
25. Semi-conductors are plenty in nature.
26. Slow moving charges will not produce electricity.
27. Electricity can be store in batteries.
28. Magnetic pole cannot be separated.
29. Freely hanging bar magnet directs in north-south direction.
30. Magnetic lines of force are thick at the centre of bar magnet.
31. Magnetic lines of force intersect each other.
32. Metals show magnetic nature when electricity flows.
33. Electro magnets are permanent magnets.
34. Natural magnets are available.
35. Sound waves do not require medium to travel.
36. Sound is an energy form.
37. Sound traverse faster through solid substances.
38. Sound waves are transverse in nature.
39. Floating of objects depends on its mass only.
40. High density objects floats in water.

**TEST OF CONCEPT ATTAINMENT IN PHYSICS (TCAP)  
ABRIDGED PARALLEL VERSION (PRE-TEST)**

**RESPONSE SHEET**

<b>Sl. No.</b>	<b>Yes</b>	<b>No</b>
1.		
2.		
3.		
4.		
5.		
6.		
7.		
8.		
9.		
10.		
11.		
12.		
13.		
14.		
15.		
16.		
17.		
18.		
19.		
20.		

<b>Sl. No.</b>	<b>Yes</b>	<b>No</b>
21.		
22.		
23.		
24.		
25.		
26.		
27.		
28.		
29.		
30.		
31.		
32.		
33.		
34.		
35.		
36.		
37.		
38.		
39.		
40.		

UNIVERSITY OF CALICUT  
DEPARTMENT OF EDUCATION

TEST OF CONCEPT ATTAINMENT IN PHYSICS (TCAP)  
ABRIDGED PARALLEL VERSION (POST-TEST)

Dr. K. Abdul Gafoor  
Associate Professor

Akhilesh, P.T.  
Research Scholar

1. അപവർത്തനം എന്ന പ്രതിഭാസം പ്രകാശം എല്ലാ ദ്രാവകങ്ങളിലും പ്രദർശിപ്പിക്കുന്നു.
2. പ്രകാശവേഗത സ്രോതസിന് അനുസൃതമായി മാറുന്നില്ല.
3. മാധ്യമത്തിലൂടെ മാത്രമേ പ്രകാശ സഞ്ചാരം സാധ്യമാവുകയുള്ളൂ.
4. ഘടകവർണ്ണങ്ങളുടെ ആകെ തുകയാണ് കറുപ്പ്.
5. പ്രകാശപ്രകീർണ്ണമാണ് ആകാശ നീലിമയ്ക്ക് കാരണം.
6. ഘടകവർണ്ണങ്ങൾ പ്രതിഫലിപ്പിക്കുന്ന പ്രതലം വെളുപ്പായി കാണപ്പെടുന്നു.
7. അപകേന്ദ്രബലം, കേന്ദ്രത്തിൽ നിന്നും പുറത്തേക്കാണ് അനുഭവപ്പെടുന്ത്.
8. പരസ്പരപൂരകങ്ങളായ ബലങ്ങളാണ്, അപകേന്ദ്രബലവും, അഭികേന്ദ്രബലവും.
9. ദൂരവും സ്ഥാനാന്തരവും എല്ലായ്പ്പോഴും വ്യത്യസ്തമായിരിക്കും.
10. സ്ഥിരാവസ്ഥയിൽ നിന്നും വ്യതിചലിക്കാൻ ബലം ആവശ്യമാണ്.
11. സ്ഥിരാവസ്ഥയിൽ തുടരാനുള്ള പ്രവണതയാണ് ജഡത്വം.
12. പിണ്ഡത്തിന്റെ വിപരീതാനുപാതത്തിലായിരിക്കും ചലിക്കുന്ന വസ്തുവിന്റെ ജഡത്വം.
13. ബാഹ്യബലംകൊണ്ട് മാത്രമേ വസ്തുവിന്റെ സ്ഥിരാവസ്ഥ മാറുകയുള്ളൂ.
14. ഘർഷണവും, ശ്യാനതയും ചലനത്തെ തടസപ്പെടുത്തുന്ന വിഭാഗം ബലങ്ങളാണ്.
15. ആക്കവും ബലവും വിപരീതാനുപാതത്തിലാണ്.
16. വസ്തുവിനേൽക്കുന്ന ആഘാതം ബലം അനുഭവപ്പെടുന്ന സമയത്തിനെ ആശ്രയിച്ചിരിക്കുന്നു.
17. പ്രവർത്തനവും പ്രതിപ്രവർത്തനവും ഒന്നിച്ചു സംഭവിക്കുകയുള്ളൂ.
18. ന്യൂട്ടന്റെ രണ്ടാം ചലന നിയമമനുസരിച്ചാണ് റോക്കറ്റുകൾ പ്രവർത്തിക്കുന്നത്.
19. ഒരു വ്യൂഹത്തിന്റെ ആകെ ആക്കം എല്ലായ്പ്പോഴും സ്ഥിരമായിരിക്കും.
20. ജലയുപത്തിന്റെ ആഴമനുസരിച്ച് ദ്രാവകമർദ്ദം കൂടുന്നു.
21. മുങ്ങിയിരിക്കുന്ന വസ്തുവിൽ എല്ലാ ദിശയിലും ദ്രാവകം ബലം പ്രയോഗിക്കുന്നു.
22. ദ്രാവകം അടങ്ങിയിരിക്കുന്ന പാത്രത്തിന്റെ അടിത്തട്ടിലേക്ക് മാത്രമാണ് ബലം പ്രയോഗിക്കുന്നത്.
23. മർദ്ദം ദ്രാവകത്തിലൂടെ തുല്യമായി വ്യാപിക്കുന്നു.

24. ശുദ്ധജലം കുചാലകമാണ്.
25. അർദ്ധചാലകങ്ങൾ ഭൂമിയിൽ വിരളമാണ്.
26. വൈദ്യുത ചാർജ്ജിന്റെ സ്ഥാനമാറ്റം കൊണ്ടും വൈദ്യുതി ഉണ്ടാകുന്നു.
27. ബാറ്ററികൾ വൈദ്യുതി ഉൽപാദിപ്പിക്കുന്നു.
28. കാന്തികധ്രുവങ്ങൾ നമ്മുടെ ആവശ്യാർത്ഥം വിഭജിക്കാം.
29. സ്വതന്ത്രമായി തുടങ്ങിയാടുന്നു ബാർ മാഗ്നറ്റിന്റെ ദിശ തെക്ക്-വടക്ക് ആയിരിക്കും.
30. ബാർ മാഗ്നറ്റിന്റെ ധ്രുവങ്ങളിലാണ് കാന്തിക ബലരേഖകൾ തിങ്ങി കാണപ്പെടുന്നത്.
31. കാന്തിക ബലരേഖകൾ പരസ്പരം വിചേദിക്കുന്നില്ല.
32. വൈദ്യുത പ്രവാഹം കാന്തിക മണ്ഡലം സൃഷ്ടിക്കുന്നില്ല.
33. സ്ഥിരാകാന്തങ്ങൾ ഉണ്ടാക്കാൻ വൈദ്യുതി ഉപയോഗിക്കുന്നു.
34. പ്രകൃതിജന്യകാന്തങ്ങൾ ലഭ്യമാണ്.
35. ശബ്ദതരംഗ പ്രേഷണത്തിന് മാധ്യമം ആവശ്യമാണ്.
36. ഉറർജ്ജരൂപമാണ് ശബ്ദം
37. ശബ്ദത്തിന് വേഗത കുറവ് ഖരപദാർത്ഥങ്ങളിലാണ്.
38. അനുപ്രസ്ഥ സ്വഭാവം കാണിക്കുന്നവയാണ് ശബ്ദതരംഗങ്ങൾ.
39. ഭാരക്കുറവ് മൂലമാണ് വസ്തുക്കൾ ജലോപരിതലത്തിൽ പൊങ്ങികിടക്കുന്നത്.
40. സാന്ദ്രത കൂടിയവ ജലോപരിതലത്തിൽ ഒഴുകി നീങ്ങും.

**UNIVERSITY OF CALICUT  
DEPARTMENT OF EDUCATION**

**TEST OF CONCEPT ATTAINMENT IN PHYSICS (TCAP)  
ABRIDGED PARALLEL VERSION (POST-TEST)**

**Dr. K. Abdul Gafoor**  
Associate Professor

**Akhilesh, P.T.**  
Research Scholar

---

**Instruction:**

Read the following statements carefully. Put a '✓' mark for your answer in the response sheet in the appropriate column against the serial number of each statement. The data collected from you will be kept confidential and used for research purpose only.

---

1. Light shows the phenomenon of refraction in all liquids.
2. Speed of light does not depend on source.
3. Light needs medium to travel.
4. Sum of the composite colours is black.
5. Blueness of sky is due to dispersion of light.
6. The plane appears white which reflects all composite colours of visible light.
7. Centrifugal force acts away from centre.
8. Both centrifugal force and centripetal forces are complementary.
9. Displacement and distance are always different.
10. Force is required to change the state of rest.
11. Tendency to continue in the state of rest is called inertia.
12. Inertia of moving object is inversely proportional to its mass.
13. Only external force can make change in the state of an object.
14. Friction and viscosity always opposes the state of motion.
15. Momentum and force are always inversely proportional to each other.
16. Impact experienced on an object by an external force depends on time.
17. Action and reaction act simultaneously.
18. Principle of rocket is Newton's Second Law of Motion.
19. Total momentum of system remains same always.
20. As the depth of water column increases liquid pressure also decreases.
21. Water exerts force on every part of an immersed body in water.
22. Liquid exerts pressure only to the bottom of container.

23. Pressure dissipates equally throughout liquid.
24. Pure water is a good conductor.
25. Semi conductors are rare in earth.
26. Change in the position of electric charge causes electricity.
27. Batteries can produce electricity.
28. Magnetic pole can divide.
29. Freely hanging bar magnet directs in North-South direction.
30. At the poles of magnet, magnetic lines of force are thick.
31. Magnetic lines of force do not intersect.
32. Electric current do not produce magnetic field.
33. Permanent magnets can be made using electricity.
34. Natural magnets are available.
35. To propagate sound medium is essential.
36. Sound is a form of energy.
37. Sound traverse slowly through solids.
38. Sound waves are longitudinal in nature.
39. Due to masslessness objects float in liquid.
40. The floating objects will have high density.

**TEST OF CONCEPT ATTAINMENT IN PHYSICS (TCAP)  
ABRIDGED PARALLEL VERSION (POST-TEST)**

**RESPONSE SHEET**

Sl. No.	Yes	No
1.		
2.		
3.		
4.		
5.		
6.		
7.		
8.		
9.		
10.		
11.		
12.		
13.		
14.		
15.		
16.		
17.		
18.		
19.		
20.		

Sl. No.	Yes	No
21.		
22.		
23.		
24.		
25.		
26.		
27.		
28.		
29.		
30.		
31.		
32.		
33.		
34.		
35.		
36.		
37.		
38.		
39.		
40.		

UNIVERSITY OF CALICUT  
DEPARTMENT OF EDUCATION

INSTRUCTIONAL PROGRAMMES  
FOR REMEDIATION OF MISCONCEPTS

**Dr. K. Abdul Gafoor**  
Associate Professor

**Akhilesh, P.T.**  
Research Scholar

**LESSON PLAN – 1**

**Standard : VIII**

**Topic : ചലനം- ന്യൂട്ടന്റെ ചലന നിയമങ്ങൾ**

**Strategy : *Concept Map Along with Conceptual Change***

**Time : 4 periods**

- ലക്ഷ്യങ്ങൾ :** അനുഭവങ്ങളിൽകൂടിയും ലഘുപരീക്ഷണങ്ങളിൽകൂടിയും ന്യൂട്ടന്റെ ചലനനിയമങ്ങളെക്കുറിച്ച് ധാരണ ഉണ്ടാക്കുകയും അവ വ്യത്യസ്ത സന്ദർഭങ്ങളിൽ പ്രയോഗിക്കുകയും ചെയ്യുക.
- : ചലന നിയമങ്ങളെക്കുറിച്ചുള്ള കൺസപ്റ്റ് മാപ്പ്-രൂപീകരിക്കുന്നതിന് കുട്ടികളെ പ്രാപ്തരാക്കുന്നതിനും
- ആശയങ്ങൾ :** ബലം, ആന്തരികബലം, മാസ്, ത്വരണം, പ്രവർത്തനം, പ്രതിപ്രവർത്തനം.

**ന്യൂട്ടന്റെ ഒന്നാം ചലന നിയമം**

- Step 1 :** ചലനനിയമങ്ങളെക്കുറിച്ച് പൊതുവായ മുൻധാരണകളും തെറ്റായ ധാരണകളും അധ്യാപകൻ കണ്ടെത്തി പട്ടികപ്പെടുത്തുന്നു.
- Step 2 :** അധ്യാപകൻ നൽകുന്ന വ്യത്യസ്ത സന്ദർഭങ്ങളിൽ എന്താണ് സംഭവിക്കുക എന്ന് മുൻകൂട്ടി പ്രവചിക്കുവാനാവശ്യപ്പെടുന്നു.
- Step 3 :** പൊതുവായ മുൻധാരണകളും തെറ്റിദ്ധാരണകളും കുട്ടികൾക്ക് തെളിവുകളുടെ അടിസ്ഥാനത്തിൽ എന്തുകൊണ്ട് തെറ്റാണെന്ന് താഴെ കൊടുത്ത പ്രവർത്തനങ്ങളിലൂടെ വിശദീകരിക്കുന്നു.
- Step 4 :** അധ്യാപകൻ ശരിയായ ആശയങ്ങൾ വിശദീകരിച്ചു നൽകുന്നു.

നേർ രേഖയിൽ ചലിച്ചുകൊണ്ടിരിക്കുന്നതോ, സ്ഥിരാവസ്ഥയിലിരിക്കുന്നതോ ആയ ഒരു വസ്തു ഒരു ബാഹ്യബലം പ്രയോഗിക്കപ്പെടുന്നതുവരെ അതെ അവസ്ഥയിൽ തുടരുന്നു.

**മുൻപ് പഠിച്ചിരിക്കേണ്ടതായ വസ്തുതകൾ**

- ▶ ബലം ഒരു വസ്തുവിന്റെ ചലനാവസ്ഥയ്ക്ക് മാറ്റം വരുത്തുന്നു.
- ▶ സമചലനം, അസമചലനം, പ്രവേഗം, ത്വരണം, സമത്വരണം എന്നിവയെ പറ്റി യുള്ള ധാരണ

**ന്യൂട്ടന്റെ ഒന്നാം ചലന നിയമം**

നേർ രേഖയിൽ ചലിച്ചു കൊണ്ടിരിക്കുന്നതോ, സ്ഥിരാവസ്ഥയിരിക്കുന്നതോ ആയ ഒരു വസ്തു ഒരു ബാഹ്യ ബലം പ്രയോഗിക്കപ്പെടുന്നതുവരെ അതെ അവസ്ഥയിൽ തുടരുന്നു.

കുട്ടികൾ ന്യൂട്ടന്റെ മൂന്ന് ചലന നിയമങ്ങളും പരസ്പരം മാറി ഉപയോഗിക്കുന്നു. അവരുടെ ധാരണ മാറ്റുന്നതിനായി മൂന്ന് സന്ദർഭങ്ങളും ഓരോന്നായി ഉദാഹരണ സഹിതം വിശദമാക്കുന്നു.

അദ്ധ്യാപകൻ താഴെ കൊടുത്തിരിക്കുന്ന ഉദാഹരണങ്ങൾ നൽകി പ്രസ്തുത സന്ദർഭത്തിൽ എന്താണ് നടക്കുക അല്ലെങ്കിൽ നടന്നിരിക്കുക എന്ന് കാര്യകാരണ സഹിതം പ്രവചിക്കാനോ അവ വിശദീകരിക്കാനോ ആവശ്യപ്പെടുന്നു.

ഒരു ചരിവുതലത്തിലൂടെ ഉരുണ്ടുവരുന്ന ഗോലി വ്യത്യസ്ത പ്രതലങ്ങളിലൂടെ ഉരുളാൻ അനുവദിക്കുക, വ്യത്യസ്ത പ്രതലങ്ങളിൽ ഗോലി സഞ്ചരിച്ച ദൂരം കണ്ടെത്തുക.

- ▶ ഉരുണ്ടുവരുന്ന ഗോലി പ്രതല വ്യത്യാസമനുസരിച്ച് വ്യത്യസ്ത ദൂരങ്ങളിൽ നിൽക്കുവാൻ കാരണം എന്ത്?
- ▶ പ്രതലം ഗോലിയുടെ സഞ്ചാരത്തിൽ എന്തെങ്കിലും പ്രതിപ്രവർത്തനമോ, ബലമോ പ്രയോഗിക്കുന്നുണ്ടോ?

അദ്ധ്യാപകൻ മേൽപറഞ്ഞ സന്ദർഭങ്ങളിൽ എന്താണ് ശരിയായ വസ്തുത എന്നും എന്തൊക്കെയാണ് കുട്ടിയുടെ വിശദീകരണത്തിന്റെ പോരായ്മ എന്നും ഉദാഹരണങ്ങളും കാരണങ്ങളും സഹിതം വിശദീകരിക്കുന്നു.

സഞ്ചരിച്ചുകൊണ്ടിരിക്കുന്ന ഏതൊരു വസ്തുവും നിശ്ചലമാവാൻ ഒരു ബാഹ്യബലം ആവശ്യമാണെന്ന് ഉരുട്ടിവിട്ട പന്ത് ബലം പ്രയോഗിച്ച് നിശ്ചലമാക്കി

കാണിച്ചുകൊടുക്കുന്നു. അതിൽ നിന്നും ഉരുണ്ടുവരുന്ന ഗോലി വ്യത്യസ്ത ദൂരങ്ങളിൽ നിൽക്കാൻ കാരണം ഉരുളുന്ന പ്രതലം വ്യത്യസ്ത അളവിലുള്ള ബലം പ്രയോഗിക്കുന്നതിനാലാണെന്നും മനസിലാക്കുന്നു.

**രണ്ടാം ചലന നിയമം**

ഒരു വസ്തുവിനുണ്ടാകുന്ന ആക്ക വ്യത്യാസത്തിന്റെ നിരക്ക് അതിനനുഭവപ്പെടുന്ന അസന്തുലിത ബാഹ്യബലത്തിന്റെ ദിശയിലും ആയിരിക്കും.

അദ്ധ്യാപകൻ താഴെ കൊടുത്തിരിക്കുന്ന ഉദാഹരണങ്ങൾ നൽകി പ്രസ്തുത സന്ദർഭത്തിൽ എന്താണ് നടക്കുക അല്ലെങ്കിൽ നടന്നിരിക്കുക എന്ന് കാര്യകാരണ സഹിതം പ്രവചിക്കാനോ അവ വിശദീകരിക്കാനോ ആവശ്യപ്പെടുന്നു.

കുട്ടികൾക്ക് നിരവധി ഉദാഹരണങ്ങൾ നൽകുന്നു.

→ ക്രിക്കറ്റ് കളിക്കാരൻ ക്യാച്ച് എടുക്കുമ്പോൾ ബോളിനോടൊപ്പം കൈ പുറകോട്ട് വലിക്കുന്നത്.

→ കോൺക്രീറ്റ് നിറച്ച പാത്രം എറിഞ്ഞുകൊടുക്കുമ്പോൾ മറ്റൊരു ജോലിക്കാൻ പിടിക്കുന്നത്.

മുകളിൽ പറഞ്ഞ സന്ദർഭങ്ങളിൽ കൈപിറകോട്ട് വലിക്കുന്നതെന്തിനാണെന്ന് അന്വേഷിക്കുന്നു.

അദ്ധ്യാപകൻ മേൽപറഞ്ഞ സന്ദർഭങ്ങളിൽ എന്താണ് ശരിയായ വസ്തുത എന്നും എന്തൊക്കെയാണ് കുട്ടിയുടെ വിശദീകരണത്തിന്റെ പോരായ്മ എന്നും ഉദാഹരണങ്ങളും കാരണങ്ങളും സഹിതം വിശദീകരിക്കുന്നു.

വിവിധ അളവിൽ ഭാരമുള്ള ബോളുകൾ കുട്ടികൾക്ക് പിടിക്കാൻ വേഗതയിലും അല്ലാതെയും. എറിഞ്ഞുകൊടുക്കുന്നു, അവ കൈ പിന്നോട്ട് വലിച്ചും, വലിക്കാതെയും പിടിക്കുന്നു, പന്തുകളുടെ ഭാരത്തിനനുസരിച്ച് കൈ വലിക്കാതെയും വലിച്ചും പിടിക്കുമ്പോൾ ഉണ്ടാകുന്ന ആഘാതം എങ്ങനെയെന്ന് മനസിലാക്കുന്നു അതുവഴി ഭാരവും ആക്കവും തമ്മിൽ ബന്ധമുണ്ടെന്ന് മനസിലാക്കുന്നു, വേഗതയുമായും ബന്ധമുണ്ടെന്നും മനസിലാക്കുന്നു.

- ▶ വെടിയുണ്ട എറിഞ്ഞുള്ള ആഘാതത്തെക്കാൾ വളരെ വലുതായിരിക്കും തോക്കിൽ നിന്നും ചീപൊഞ്ഞുവരുന്ന വെടിയുണ്ട ഉണ്ടാക്കുന്ന ആഘാതം.
- ▶ ഓട്ടോറിക്ഷ ഇടിക്കുമ്പോൾ ഒരു കാറിനുണ്ടാവുന്ന ആഘാതത്തെക്കാൾ വലുതായിരിക്കും ബസ് കാറിനിടിച്ചുണ്ടാകുന്ന ആഘാതം എന്നും വിശദമാക്കുന്നു. അതുവഴി ആക്ക വ്യത്യാസം ബാഹ്യബലം അതിന്റെ ദിശ എന്നിവയെ ബന്ധപ്പെട്ടിരിക്കുന്നു എന്ന് മനസ്സിലാക്കാം.

**മൂന്നാം ചലന നിയമം**

അദ്ധ്യാപകൻ താഴെ കൊടുത്തിരിക്കുന്ന ഉദാഹരണങ്ങൾ നൽകി പ്രസ്തുത സന്ദർഭത്തിൽ എന്താണ് നടക്കുക അല്ലെങ്കിൽ നടന്നിരിക്കുക എന്ന് കാര്യകാരണ സഹിതം പ്രവചിക്കാനോ അവ വിശദീകരിക്കാനോ ആവശ്യപ്പെടുന്നു.

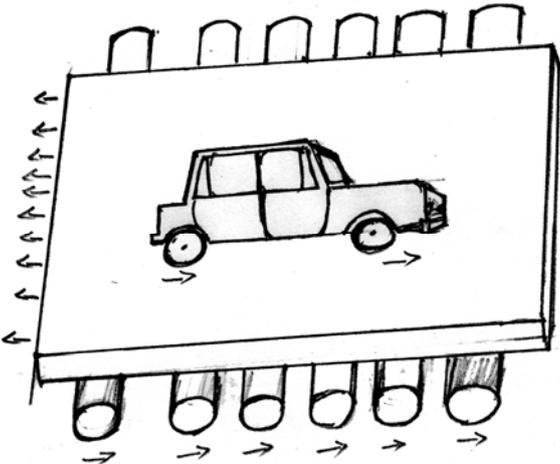

ഒരേ ദിശയിൽ അടുപ്പിച്ച് നിരത്തിവെച്ചിരിക്കുന്ന ഉരുളൻ മരത്തടികൾ/ ഇരുമ്പ് പൈപ്പുകൾക്ക് മുകളിൽ വെച്ചിരിക്കുന്ന പലകയിൽ മരത്തടികൾക്ക് കുറുകെയുള്ള ദിശയിൽ പൊട്ടൻഷ്യാൽ എന്നർജികൊണ്ട് പ്രവർത്തിക്കുന്ന ടോയ്കാർ പ്രവർത്തിക്കുക. കാർ മുന്നോട്ട് പോകുമ്പോൾ മരപലക പിന്നോട്ടേക്കും തടികൾ എതിർദിശയിലും നീങ്ങുന്നു.

അദ്ധ്യാപകൻ മേൽപറഞ്ഞ സന്ദർഭങ്ങളിൽ എന്താണ് ശരിയായ വസ്തുത എന്നും എന്തൊക്കെയാണ് കൂട്ടിയുടെ വിശദീകരണത്തിന്റെ പോരായ്മ എന്നും ഉദാഹരണങ്ങളും കാരണങ്ങളും സഹിതം വിശദീകരിക്കുന്നു.

ഇതിൽ നിന്നും കാർ മൂന്നോട്ടേക്ക് നീങ്ങുമ്പോൾ കാർ എതിർദിശയിൽ പല കയിൽ ഒരുമ്പലം പ്രയോഗിക്കുന്നു അതിനാലാണ് പലക പിന്നോട്ടേക്ക് നീങ്ങുന്നത്, പിന്നോട്ടേക്ക് നീങ്ങുന്ന പലകത്തടികളിൽ എതിർദിശയിൽ ബലം പ്രയോഗിക്കുന്നു മരത്തടികൾ മൂന്നോട്ടേക്ക് നീങ്ങുന്നു. ഇതിൽ നിന്നും പ്രയോഗിക്കപ്പെടുന്ന ബലത്തിന് എതിർദിശയിൽ ഒരുമ്പലം പ്രയോഗിക്കപ്പെടുന്നു എന്ന് മനസ്സിലാക്കാം.

- ▶ തോണിയിൽ നിന്ന് കരയിലേക്ക് ചാടുമ്പോൾ തോണി എതിർ ദിശയിൽ നീങ്ങുന്നു.
- ▶ വായു നിറച്ച ബലൂണിൽ നിന്ന് വായുപുറത്തുപോകുമ്പോൾ ബലൂൺ വായു പ്രവാഹത്തിനെതിരെ ചിലിക്കുന്നു.
- ▶ റോക്കറ്റ് മൂന്നോട്ടേക്ക് പോവുന്നത് വാതകപ്രവാഹം എതിർദിശയിൽ ഉണ്ടാകുന്നതു കൊണ്ടാണ്.

ഈ ഉദാഹരണങ്ങൾവെച്ച് ഏതൊരു പ്രവർത്തനത്തിനും ഒരു പ്രതിപ്രവർത്തനം ഉണ്ടെന്ന് വിശദീകരിക്കുകയും കൂടുതൽ ഉദാഹരണങ്ങൾ കണ്ടെത്താൻ ആവശ്യപ്പെടുകയും ചെയ്യുന്നു.

അധ്യാപകൻ താഴെ കൊടുത്തിരിക്കുന്ന ഉദാഹരണങ്ങൾ നൽകി പ്രസ്തുത സന്ദർഭത്തിൽ എന്താണ് നടക്കുക അല്ലെങ്കിൽ നടന്നിരിക്കുക എന്ന് കാര്യകാരണ സഹിതം പ്രവചിക്കാനോ അവ വിശദീകരിക്കാനോ ആവശ്യപ്പെടുന്നു.

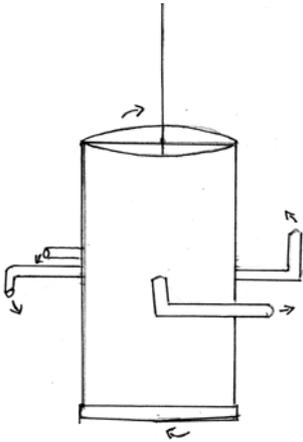

ചിത്രത്തിൽ കാണുന്നപോലെ പിവിസി പൈപ്പിൽ 'L' ആകൃതിയിൽ സ്ക്രോകൾ പിടിപ്പിക്കുക, പൈപ്പിന്റെ അടിവശം മുടിയതും മുകൾവശം തുറന്നതു

മാണ്, പൈപ്പിൽ വെള്ളം നിറച്ച് തൂക്കിയിടുക വെള്ളം ശക്തിയായി സ്ട്രോകളിൽ കൂടെ പുറത്തേക്ക് ചീറ്റുന്നു. അദ്ധ്യാപകൻ മേൽപറഞ്ഞ സന്ദർഭങ്ങളിൽ എന്താണ് ശരിയായ വസ്തുത എന്നും എന്തൊക്കെയാണ് കുട്ടിയുടെ വിശദീകരണത്തിന്റെ പോരായ്മ എന്നും ഉദാഹരണങ്ങളും കാരണങ്ങളും സഹിതം വിശദീകരിക്കുന്നു. വെള്ളം പ്രവഹിക്കുന്നതിന്റെ എതിർദിശയിൽ പൈപ്പ് കറങ്ങുന്നു. വെള്ളം പുറത്തേക്ക് പ്രവഹിക്കുമ്പോൾ നടക്കുന്ന പ്രവൃത്തിക്ക് എതിരായ് പൈപ്പിൽ ഒരു ബലം എതിർ ദിശയിൽ പ്രവർത്തിക്കുന്നതിനാൽ ആണ് എതിർ ദിശയിൽ കറങ്ങുന്നത്.

അദ്ധ്യാപകൻ താഴെ കൊടുത്തിരിക്കുന്ന ഉദാഹരണങ്ങൾ നൽകി പ്രസ്തുത സന്ദർഭത്തിൽ എന്താണ് നടക്കുക അല്ലെങ്കിൽ നടന്നിരിക്കുക എന്ന് കാര്യകാരണ സഹിതം പ്രവചിക്കാനോ അവ വിശദീകരിക്കാനോ ആവശ്യപ്പെടുന്നു.

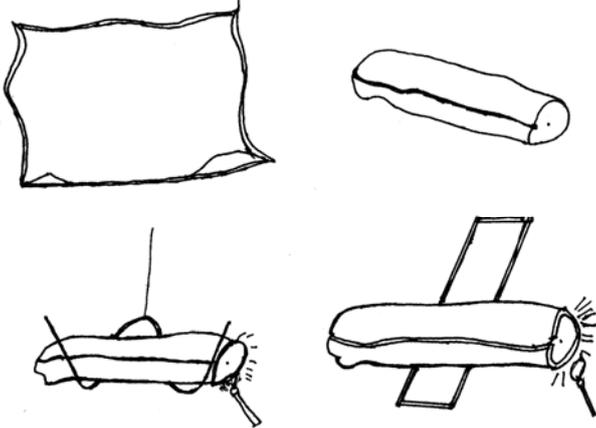

ഒരു കടലാസിൽ തീപ്പെട്ടികമ്പുകൾ ചിത്രത്തിൽ കാണുന്നപോലെ പൊതിഞ്ഞു എടുക്കുക. ഒരു കൊളുത്തിൽ തറക്കു ലംബമായി തൂക്കി ഇടുക, തീപ്പെട്ടികമ്പുകളുടെ മരുന്നുള്ള ഭാഗത്ത് കടലാസ്‌പൊതിക്ക് തീകൊടുക്കുക. അദ്ധ്യാപകൻ മേൽ പറഞ്ഞ സന്ദർഭങ്ങളിൽ എന്താണ് ശരിയായ വസ്തുത എന്നും എന്തൊക്കെയാണ് കുട്ടിയുടെ വിശദീകരണത്തിന്റെ പോരായ്മ എന്നും ഉദാഹരണങ്ങളും കാരണങ്ങളും സഹിതം വിശദീകരിക്കുന്നു. കടലാസിനുള്ളിലെ തീപ്പെട്ടി കമ്പുകൾ കത്തുകയും കടലാസ് പൊതി എതിർവശത്തേക്ക് നീങ്ങുകയും ചെയ്യുന്നു, കമ്പ് കത്തുമ്പോൾ ഒരു ദിശയിൽ കടലാസ് പൊതി സഞ്ചരിക്കുകയും ചെയ്യുന്നു.

ഇതിൽ നിന്നെല്ലാം ഒരു ദിശയിൽ ബലം പ്രയോഗിക്കപ്പെടുമ്പോൾ ആ ബലത്തിന് തുല്യമായ അളവിൽ എതിർ ദിശയിൽ ബലം പ്രയോഗിക്കപ്പെടുന്നു എന്ന് മനസിലാക്കാം. ഇതിനെയാണ് ന്യൂട്ടന്റെ മൂന്നാം ചലനനിയമം എന്ന് പറയുന്നത്.

ന്യൂട്ടന്റെ മൂന്ന് ചലനനിയമങ്ങളും മേൽപറഞ്ഞ പ്രവർത്തനങ്ങളിലൂടെ കൂട്ടി കൾ മനസിലാക്കുകയും വേർതിരിച്ചറിയുകയും ചെയ്യുകയും അവ ഉൾക്കൊള്ളിച്ച് കൺസപ്റ്റ് മാപ്പ് തയ്യാറാക്കുകയും ചെയ്യുന്നു, കൂട്ടികൾ നിർമ്മിച്ച മാപ്പും അധ്യാപകൻ തയ്യാറാക്കിയ മാപ്പും താരതമ്യം ചെയ്ത് അധ്യാപകൻ ആശയങ്ങൾ ക്രോഡീകരിക്കുന്നതിനും വ്യക്തത വരുത്തുന്നതിനും സഹായിക്കുന്നു.

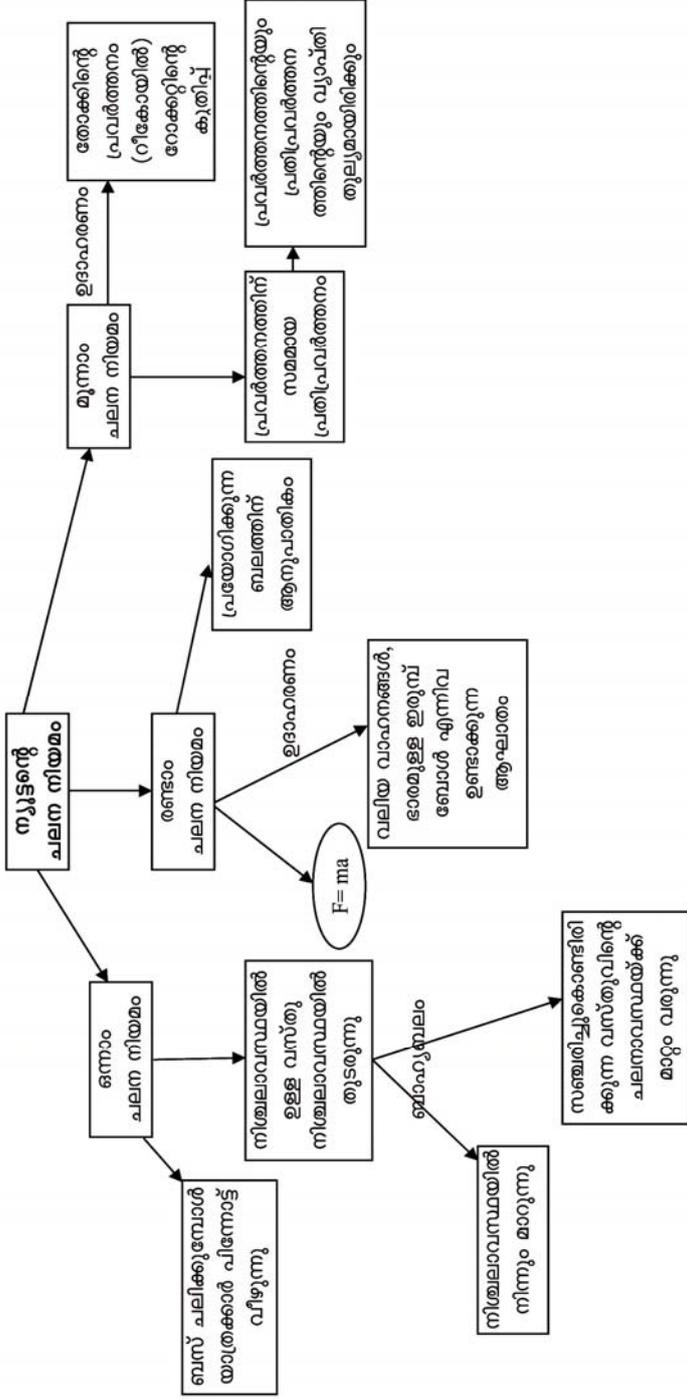

**LESSON PLAN – 2**

**Standard** : VIII  
**Topic** : പാസ്കൽ നിയമം  
**Strategy** : *Concept Map*  
**Time** : 1 period

**ലക്ഷ്യങ്ങൾ** : ദ്രവങ്ങളിൽ മർദ്ധവ്യാപനം എങ്ങിനെ എന്ന് വിശദമായി മനസ്സിലാക്കുന്നതിന്, കൺസപ്റ്റ് മാപ്പ് നിർമ്മിക്കുന്നതിന്.  
**ആശയങ്ങൾ** : മർദ്ധം, വ്യാപകമർദ്ധം, മർദ്ധവ്യാപനം

**പാസ്കൽ നിയമം**

നിശ്ചലാവസ്ഥയിലുള്ള ദ്രവത്തിന്റെ ഏതെങ്കിലും ഒരു ഭാഗത്ത് പ്രയോഗിക്കുന്ന മർദ്ധം അതിന്റെ എല്ലാ ഭാഗത്തും ഒരേ അളവിൽ അനുഭവപ്പെടും.

ഉൾവശം തെളിഞ്ഞു കാണുന്ന ബോട്ടിലിന്റെ മധ്യഭാഗത്ത് L ആകൃതിയിൽ, സ്ക്രോകൾ ദ്വാരമിട്ട് ഉറപ്പിച്ച് നിർത്തുക. ബോട്ടിലിന്റെ വായ്ഭാഗത്തുകൂടെ ജലം നിറക്കുക. എല്ലാ സ്ക്രോകളിലും ഒരേ നിരപ്പിൽ ജലം നിറയുന്നു.

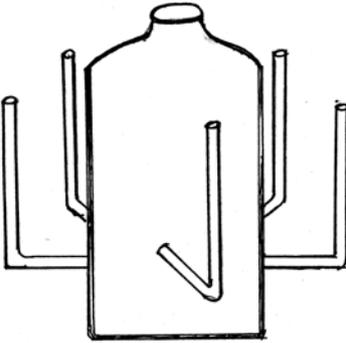

ബോട്ടിലിന്റെ വായ്ഭാഗത്തുകൂടെ ഊതുക എല്ലാ സ്ക്രോകളിൽകൂടെയും തുല്യ അളവിൽ ജലം പുറത്തുവരുന്നു, കാരണം വായ്ഭാഗത്തുകൂടെ പ്രയോഗിക്കപ്പെടുന്ന മർദ്ധം തുല്യ അളവിൽ എല്ലായിടത്തും എത്തുന്നതിനാലാണ്.

ബോട്ടിലിലെ ജലം മാറ്റി സ്ക്രോകളിൽ ബലൂണുകൾ ഘടിപ്പിക്കുക വായഭാഗത്തുകൂടെ ഊതുക എല്ലാ ബലൂണുകളും ഒരേ സമയത്ത് നിറയുന്നത് കാണാം.

ഒരു ടൂത്ത് പേസ്റ്റ് ട്യൂബ് എടുത്ത് അതിന്റെ പിൻവശത്ത് മർദ്ദം പ്രയോഗിക്കുക. വായ്ഭാഗത്തുകൂടെ പേസ്റ്റ് പുറത്തുവരുന്നതിന്റെ കാരണം വിശദീകരിക്കുക.

പഠനപ്രവർത്തനങ്ങളിലൂടെയും, അനുബന്ധ ചർച്ചകളിലൂടെയും പാസ്കൽ നിയമത്തെക്കുറിച്ച് ധാരണ രൂപീകരിക്കുകയും കൺസപ്റ്റ് മാപ്പ് നിർമ്മിക്കുകയും ചെയ്യുന്നു. കൺസപ്റ്റ് മാപ്പിന്റെ സഹായത്താൽ അധ്യാപകൻ വിശദാംശങ്ങൾ ക്രോഡീകരിക്കുകയും ചെയ്യുന്നു കുട്ടികൾ നിർമ്മിച്ച കൺസപ്റ്റ് മാപ്പ് അധ്യാപകൻ നൽകിയ മാപ്പുമായി താരതമ്യപ്പെടുത്തുകയും ചെയ്യുന്നു.

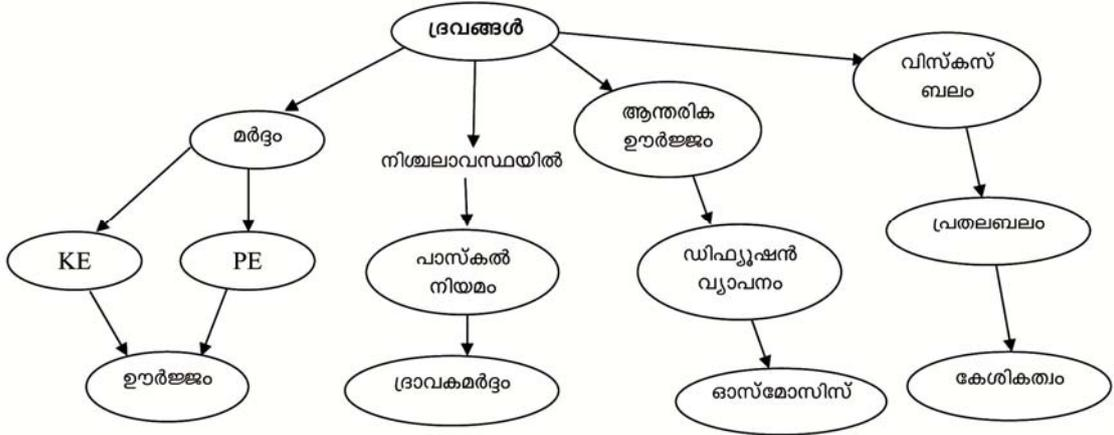

**LESSON PLAN – 3**

**Standard : VIII**  
**Topic : ദ്രാവകമർദ്ദം**  
**Strategy : Conceptual Change**  
**Time : 1 period**

**ലക്ഷ്യങ്ങൾ :** മർദ്ദം എന്താണെന്ന് അറിയുന്നതിന് ദ്രാവകം സ്ഥിതി ചെയ്യുന്ന പാത്രത്തിന്റെ വശങ്ങളിലേക്കും, താഴേക്കും മർദ്ദം പ്രയോഗിക്കുന്നുണ്ട് എന്ന് മനസ്സിലാക്കുന്നതിന്, അണക്കെട്ടുകളിൽ ജലം വൻതോതിൽ മർദ്ദം ചെലുത്തുന്നു എന്നും മനസ്സിലാക്കുന്നതിനും.

**ആശയങ്ങൾ :** മർദ്ദം, വിസ്തീർണ്ണം, വ്യാപകമർദ്ദം, etc.

**ദ്രാവകമർദ്ദം**

- Step 1 : ദ്രാവക മർദ്ദത്തെക്കുറിച്ച് പൊതുവായ മുൻധാരണകളും തെറ്റായ ധാരണകളും അധ്യാപകൻ കണ്ടെത്തി പട്ടികപ്പെടുത്തുന്നു.
- Step 2 : അധ്യാപകൻ നൽകുന്ന വ്യത്യസ്ത സന്ദർഭങ്ങളിൽ എന്താണ് സംഭവിക്കുക എന്ന് മുൻകൂട്ടി പ്രവചിക്കുവാനാവശ്യപ്പെടുന്നു.
- Step 3 : പൊതുവായ മുൻധാരണകളും തെറ്റിദ്ധാരണകളും കുട്ടികൾക്ക് തെളിവുകളുടെ അടിസ്ഥാനത്തിൽ എന്തുകൊണ്ട് തെറ്റാണെന്ന് താഴെ കൊടുത്ത പ്രവർത്തനങ്ങളിലൂടെ വിശദീകരിക്കുന്നു.
- Step 4 : അധ്യാപകൻ ശരിയായ ആശയങ്ങൾ വിശദീകരിച്ചു നൽകുന്നു.

അധ്യാപകൻ താഴെ കൊടുത്തിരിക്കുന്ന ഉദാഹരണങ്ങൾ നൽകി പ്രസ്തുത സന്ദർഭത്തിൽ എന്താണ് നടക്കുക അല്ലെങ്കിൽ നടന്നിരിക്കുക എന്ന് കാര്യകാരണ സഹിതം പ്രവചിക്കാനോ അവ വിശദീകരിക്കാനോ ആവശ്യപ്പെടുന്നു.

ഒരേ രൂപത്തിലുള്ള പാത്രങ്ങളിൽ വ്യത്യസ്ത ഉയരങ്ങളിൽ ദ്വാരമിടുക ദ്വാരം മെഴുകു ഉപയോഗിച്ച് അടച്ചുവെക്കുക.

പാത്രത്തിൽ ജലം നിറച്ച് ദ്വാരങ്ങൾ ഓരോന്നിലൂടെയും ഒരു സമയത്ത് ഒന്നെന്ന് രീതിയിൽ ജലം പ്രവഹിക്കാൻ അനുവദിക്കുക. ജലപ്രവാഹം എത്തി ചേർന്ന ദൂരം അടയാളപ്പെടുത്തുക.

അദ്ധ്യാപകൻ മേൽപറഞ്ഞ സന്ദർഭങ്ങളിൽ എന്താണ് ശരിയായ വസ്തുത എന്നും എന്തൊക്കെയാണ് കുട്ടിയുടെ വിശദീകരണത്തിന്റെ പോരായ്മ എന്നും ഉദാഹരണങ്ങളും കാരണങ്ങളും സഹിതം വിശദീകരിക്കുന്നു.

ഉയരം കൂടുന്നതിനനുസരിച്ച് ജലം പ്രവഹിക്കുന്നതിന്റെ ശക്തി കുറഞ്ഞു വരുന്നത് കാണാം, എല്ലാം ദ്വാരങ്ങളിലൂടെയും ഒരേ സമയം തന്നെ ജലം പുറത്തുവരാൻ അനുദിക്കുക, ഏറ്റവും താഴത്ത് ഉള്ള ദ്വാരത്തിലൂടെ ജലം കൂടുതൽ ദൂരത്തേക്ക് പ്രവഹിക്കുന്നു ഉയരം കൂടുന്നതനുസരിച്ച് ശക്തി കുറഞ്ഞ്, ദൂരം കുറഞ്ഞ് വരുന്നതായ് കാണാം.

ഇതിൽ നിന്നും ജലയുപത്തിന്റെ ഉയരം കൂടുന്നതനുസരിച്ച് മർദ്ധം കൂടുന്നു എന്ന് മനസിലാക്കാം, അണക്കെട്ടുകളിൽ ജലനിരപ്പ് കൂടുന്നതനുസരിച്ച് മർദ്ധം കൂടുന്നു എന്ന് മനസിലാക്കാം.

അണക്കെട്ടുകൾ തകർന്നാൽ വൻതോതിൽ നാശനഷ്ടങ്ങൾ ഉണ്ടാകും എന്ന് പറയുന്നതിന്റെ കാരണം, അണക്കെട്ടിന്റെ ഉയരം, ജലയുപത്തിന്റെ ഉയരം, സംഭരണിയുടെ വിസ്തീർണ്ണം എന്നിവയുടെ അടിസ്ഥാനത്തിൽ കുട്ടികൾ മനസിലാക്കുന്നു.

LESSON PLAN - 4

**Standard** : VIII  
**Topic** : ആപേക്ഷിക സാന്ദ്രത  
**Strategy** : *Concept Map*  
**Time** : 1 period

**ലക്ഷ്യങ്ങൾ** : സാന്ദ്രത അപേക്ഷിക സാന്ദ്രത എന്നിവ അറിയുന്നതിന്.  
**ആശയങ്ങൾ** : സാന്ദ്രത, അപേക്ഷിക സാന്ദ്രത

**ആപേക്ഷിക സാന്ദ്രത**

ഒരു പാത്രത്തിലെ ജലത്തിൽ പെൻസിലിന്റെ ഇറേസർ ഭാഗത്ത് ഭാരം കൂടിയ പിൻ കുത്തി പെൻസിൽ ലംബമായി നിൽക്കുന്ന തരത്തിൽ നിക്ഷേപിക്കുക, പെൻസിലിന്റെ അടിവശം എവിടെയാണെന്ന് മാർക്ക് ചെയ്യുക.

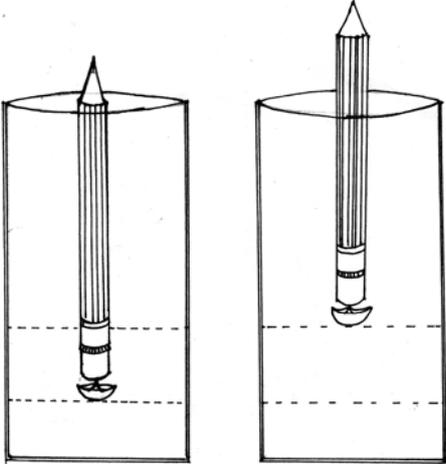

ഇതേ വലിപ്പമുള്ള രൂപവ്യത്യാസമില്ലാത്ത മറ്റൊരു പാത്രത്തിൽ മണ്ണെണ്ണ എടുത്തു മേൽപറഞ്ഞ പരീക്ഷണം ആവർത്തിക്കുക പെൻസിലിന്റെ അടിവശം എവിടെയാണ് മാർക്ക് ചെയ്യുക. പെൻസിൽ ജലത്തിനേക്കാൾ ഉയർന്നു നിൽക്കുന്നതായ് കാണാം.

ഒരു പാത്രത്തിലെ ജലത്തിൽ കോഴിമുട്ട നിക്ഷേപിക്കുക. മുട്ട ജലത്തിൽ താഴ്ന്നിരിക്കുന്നതായ് കാണാം, ജലത്തിൽ ഉപ്പ് കലർത്തി മുട്ട നിക്ഷേപിക്കുക, കോഴിമുട്ട ഉയർന്നു നിൽക്കുന്നതായ് കാണാം ഇതിന് കാരണം ജലത്തിന്റെയും ഉപ്പുവെള്ളത്തിന്റെയും സാന്ദ്രത വ്യത്യാസമാണെന്ന് വിശദീകരിക്കുന്നു.

പെൻസിൽ ജലത്തിൽ ഉള്ളതിനേക്കാൾ മണ്ണണ്ണയിൽ ഉയർന്നു നിൽക്കുന്നത് മണ്ണണ്ണ ജലത്തേക്കാൾ സാന്ദ്രത കൂടിയതിനാലാണെന്ന് മനസിലാക്കുന്നു.

അപേക്ഷിക സാന്ദ്രത എന്താണെന്ന് മേൽപറഞ്ഞ പ്രവർത്തനങ്ങളുടെ ആപേക്ഷിക സാന്ദ്രതയെക്കുറിച്ച് ധാരണാ രൂപീകരിക്കുകയും, അത് അളക്കുന്നത് ജലവുമായി താരതമ്യം ചെയ്താണെന്ന് വിശദീകരിക്കുന്നു (ജലത്തെ അടിസ്ഥാനപെടുത്തി).

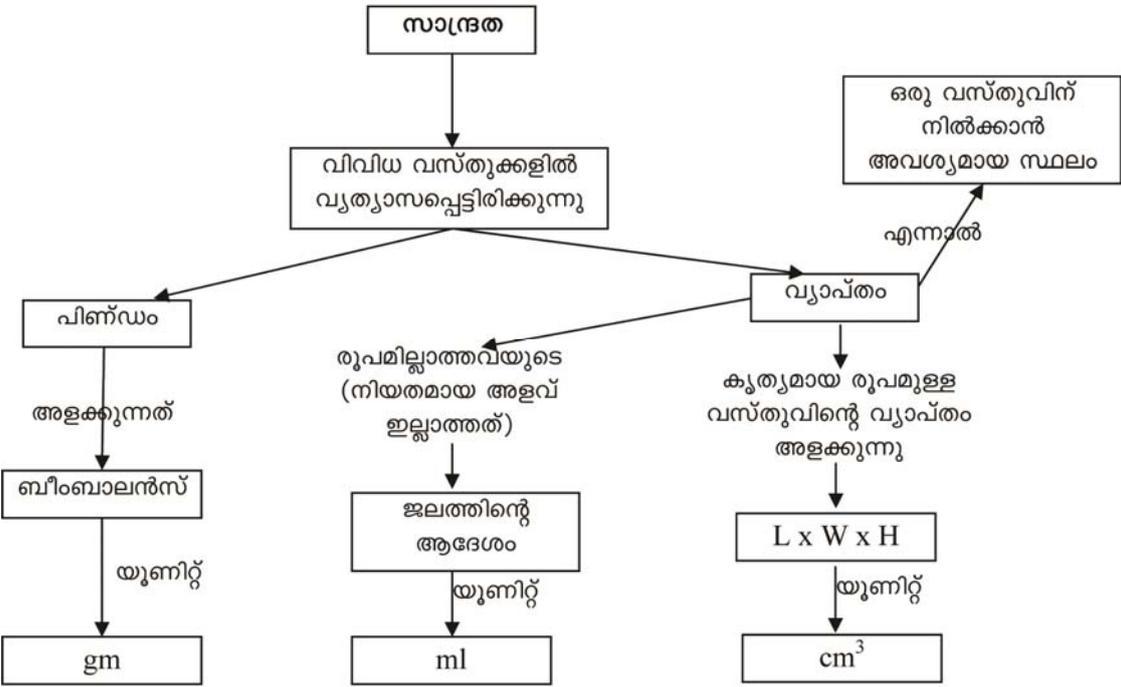

**LESSON PLAN - 5**

**Standard : VIII**  
**Topic : കാന്തിക മണ്ഡലം**  
**Strategy : Conceptual Change**  
**Time : 2 periods**

**ലക്ഷ്യങ്ങൾ :** കാന്തത, കാന്തിക വസ്തുക്കൾ, മുതലായവയെക്കുറിച്ച് അറിയുന്നതിന്  
 : കാന്തികബലരേഖകളുടെ സാന്നിധ്യം മനസ്സിലാക്കുന്നതിന്.  
**ആശയങ്ങൾ :** കാന്തത, കാന്തിക വസ്തുക്കൾ, കാന്തിക മണ്ഡലം, കാന്തിക ബലരേഖകൾ, കാന്തധ്രുവങ്ങൾ മുതലായവ.

**കാന്തിക മണ്ഡലം**

- Step 1 : കാന്തികമണ്ഡലങ്ങളെക്കുറിച്ച് പൊതുവായ മുൻധാരണകളും തെറ്റായ ധാരണകളും അധ്യാപകൻ കണ്ടെത്തി പട്ടികപ്പെടുത്തുന്നു.
- Step 2 : അധ്യാപകൻ നൽകുന്ന വ്യത്യസ്ത സന്ദർഭങ്ങളിൽ എന്താണ് സംഭവിക്കുക എന്ന് മുൻകൂട്ടി പ്രവചിക്കുവാനാവശ്യപ്പെടുന്നു.
- Step 3 : പൊതുവായ മുൻധാരണകളും തെറ്റിദ്ധാരണകളും കുട്ടികൾക്ക് തെളിവുകളുടെ അടിസ്ഥാനത്തിൽ എന്തുകൊണ്ട് തെറ്റാണെന്ന് താഴെ കൊടുത്ത പ്രവർത്തനങ്ങളിലൂടെ വിശദീകരിക്കുന്നു.
- Step 4 : അധ്യാപകൻ ശരിയായ ആശയങ്ങൾ വിശദീകരിച്ചു നൽകുന്നു.

അധ്യാപകൻ താഴെ കൊടുത്തിരിക്കുന്ന ഉദാഹരണങ്ങൾ നൽകി പ്രസ്തുത സന്ദർഭത്തിൽ എന്താണ് നടക്കുക അല്ലെങ്കിൽ നടന്നിരിക്കുക എന്ന് കാര്യകാരണ സഹിതം പ്രവചിക്കാനോ അവ വിശദീകരിക്കാനോ ആവശ്യപ്പെടുന്നു.

ഒരു ഗ്ലാസ് പ്ലെയിറ്റിന് മുകളിൽ ഇരുമ്പ്പൊടി വിതറുക ഗ്ലാസിന്റെ അടിവശത്തുകൂടെ ഒരു കാന്തം സാവധാനം ചലിപ്പിക്കുക. അധ്യാപകൻ മേൽപറഞ്ഞ സന്ദർഭങ്ങളിൽ എന്താണ് ശരിയായ വസ്തുത എന്നും എന്തൊക്കെയാണ് കുട്ടിയുടെ വിശദീകരണത്തിന്റെ പോരായ്മ എന്നും ഉദാഹരണങ്ങളും കാരണങ്ങളും സഹിതം വിശദീകരിക്കുന്നു. ഇരുമ്പ്പൊടി പ്രത്യേകരീതിയിൽ ക്രമീകരിക്കപ്പെടുന്നത് കാണാം കാന്തത്തിന്റെ ഒരുവശത്തു നിന്ന് തുടങ്ങി മറ്റൊരു വശത്ത് അവസാനിക്കുന്ന രീതിയിൽ കാണപ്പെടുന്നു.

മേൽപറഞ്ഞ പ്രവർത്തനം തുല്യഅകലത്തിൽ സ്ഥിതി ചെയ്യുന്ന രണ്ട് കാന്തങ്ങൾ കൊണ്ട് ആവർത്തിക്കുക.

ഒരു കാന്തത്തിന്റെ നോർത്ത് പോളിൽ നിന്ന് ആരംഭിച്ച് മറ്റേതിന്റെ സൗത്ത്പോളിൽ അവസാനിക്കുന്ന തരത്തിൽ ഇരുമ്പ്പൊടി ക്രമീകരിക്കപ്പെടുന്നത് കാണാം നോർത്ത്, സൗത്ത് പോളുകൾ മാറ്റി ക്രമീകരിച്ചാൽ എന്ത് സംഭവിക്കുന്നു എന്ന് വിശദീകരിക്കുന്നു.

അധ്യാപകൻ താഴെ കൊടുത്തിരിക്കുന്ന ഉദാഹരണങ്ങൾ നൽകി പ്രസ്തുത സന്ദർഭത്തിൽ എന്താണ് നടക്കുക അല്ലെങ്കിൽ നടന്നിരിക്കുക എന്ന് കാര്യകാരണ സഹിതം പ്രവചിക്കാനോ അവ വിശദീകരിക്കാനോ ആവശ്യപ്പെടുന്നു.

ഇരുമ്പ് പൊടി മാറ്റി അതിന്റെ സ്ഥാനത്ത് കോമ്പസ് നീഡിലുകൾ ചിത്രത്തിൽ കാണുന്ന രീതിയിൽ ക്രമീകരിക്കുക. അധ്യാപകൻ മേൽപറഞ്ഞ സന്ദർഭങ്ങളിൽ എന്താണ് ശരിയായ വസ്തുത എന്നും എന്തൊക്കെയാണ് കുട്ടിയുടെ വിശദീകരണത്തിന്റെ പോരായ്മ എന്നും ഉദാഹരണങ്ങളും കാരണങ്ങളും സഹിതം വിശദീകരിക്കുന്നു. നേരത്തെ ഇരുമ്പ് പൊടികൾ ക്രമീകരിച്ച കാന്തിക ബല രേഖകളിൽ കോമ്പസ് നീഡിലിന്റെ സൂചി ക്രമീകരിക്കുന്നത് കാണാം ഇതിൽ നിന്നും കാന്തിക ബലരേഖകൾ ഒരു ധ്രുവത്തിൽ നിന്നും ആരംഭിച്ച് മറ്റൊരു വത്തിൽ അവസാനിക്കുന്നു എന്ന് വിശദീകരിച്ചു നൽകുന്നു.

കാന്തം ഇരുമ്പിനെ ആകർഷിക്കുന്നത് കണ്ടിട്ടില്ലേ, കാന്തം വളരെ അകലത്തിൽ സ്ഥിതിചെയ്യുന്ന ഇരുമ്പാണിയെ ആകർഷിക്കുമോ, ഇല്ല ഓരോ കാന്തവും പ്രത്യേക അകലത്തിൽ മാത്രമേ ആകർഷിക്കുകയുള്ളൂ.

മേൽ വിവരിച്ച പ്രവർത്തനങ്ങളിലൂടെ കാന്തത, കാന്തിക മണ്ഡലം എന്നിവയെക്കുറിച്ച് ധാരണ നേടുന്നു.

**LESSON PLAN - 6**

**Standard : VIII**

**Topic : വൈദ്യുതിക്ക് കാന്തിക മണ്ഡലം നിർമ്മിക്കാൻ സാധിക്കും**

**Strategy : Conceptual Change**

**Time : 1 period**

**ലക്ഷ്യങ്ങൾ :** വൈദ്യുതി കാന്തിക വൽക്കരണം എങ്ങനെ നടക്കുന്നു, വൈദ്യുത കാന്തം, സ്ഥിരകാന്തം, കാന്തിക പ്രേരണം എന്നിവ മനസ്സിലാക്കുന്നതിന്.

**ആശയങ്ങൾ :** കാന്തത, കാന്തിക പ്രേരണം, കാന്തിക മണ്ഡലം മുതലായവ.

**വൈദ്യുതിക്ക് കാന്തിക മണ്ഡലം നിർമ്മിക്കാൻ സാധിക്കും**

**Step 1 :** വൈദ്യുതകാന്തികമണ്ഡലങ്ങളെക്കുറിച്ച് പൊതുവായ മുൻധാരണകളും തെറ്റായ ധാരണകളും അധ്യാപകൻ കണ്ടെത്തി പട്ടികപ്പെടുത്തുന്നു.

**Step 2 :** അധ്യാപകൻ നൽകുന്ന വ്യത്യസ്ത സന്ദർഭങ്ങളിൽ എന്താണ് സംഭവിക്കുക എന്ന് മുൻകൂട്ടി പ്രവചിക്കുവാനാവശ്യപ്പെടുന്നു.

**Step 3 :** പൊതുവായ മുൻധാരണകളും തെറ്റിദ്ധാരണകളും കുട്ടികൾക്ക് തെളിവുകളുടെ അടിസ്ഥാനത്തിൽ എന്തുകൊണ്ട് തെറ്റാണെന്ന് താഴെ കൊടുത്ത പ്രവർത്തനങ്ങളിലൂടെ വിശദീകരിക്കുന്നു.

**Step 4 :** അധ്യാപകൻ ശരിയായ ആശയങ്ങൾ വിശദീകരിച്ചു നൽകുന്നു.

**വൈദ്യുതി മാഗ്നറ്റിക് ഫീൽഡ് അഥവാ കാന്തിക മണ്ഡലം ഉണ്ടാക്കുന്നു**

അധ്യാപകൻ താഴെ കൊടുത്തിരിക്കുന്ന ഉദാഹരണങ്ങൾ നൽകി പ്രസ്തുത സന്ദർഭത്തിൽ എന്താണ് നടക്കുക അല്ലെങ്കിൽ നടന്നിരിക്കുക എന്ന് കാര്യകാരണ സഹിതം പ്രവചിക്കാനോ അവ വിശദീകരിക്കാനോ ആവശ്യപ്പെടുന്നു.

ഒരു മാഗ്നറ്റ് കൊണ്ട് മേശപുറത്തിരിക്കുന്ന ചെറിയ ആണികൾ ആകർഷിക്കപ്പെടുന്നത് വിശദീകരിക്കുന്നു.

കാന്തത്തിനു സമീപം ഇരുമ്പുപൊടി വിതറുക. ഇരുമ്പുപൊടി കാന്തികബല രേഖകളുടെ രൂപത്തിൽ ക്രമീകരിക്കപ്പെടുന്നത് വിശദീകരിക്കുക കാന്തത്തിന്റെ കാന്തികമണ്ഡലത്തിലാണ് ഇരുമ്പുപൊടിക്രമീകരിക്കപ്പെടുന്നതെന്ന് വിശദീകരിക്കുക.

അദ്ധ്യാപകൻ മേൽപറഞ്ഞ സന്ദർഭങ്ങളിൽ എന്താണ് ശരിയായ വസ്തുത എന്നും എന്തൊക്കെയാണ് കുട്ടിയുടെ വിശദീകരണത്തിന്റെ പോരായ്മ എന്നും ഉദാഹരണങ്ങളും കാരണങ്ങളും സഹിതം വിശദീകരിക്കുന്നു.

അദ്ധ്യാപകൻ താഴെ കൊടുത്തിരിക്കുന്ന ഉദാഹരണങ്ങൾ നൽകി പ്രസ്തുത സന്ദർഭത്തിൽ എന്താണ് നടക്കുക അല്ലെങ്കിൽ നടന്നിരിക്കുക എന്ന് കാര്യകാരണ സഹിതം പ്രവചിക്കാനോ അവ വിശദീകരിക്കാനോ ആവശ്യപ്പെടുന്നു.

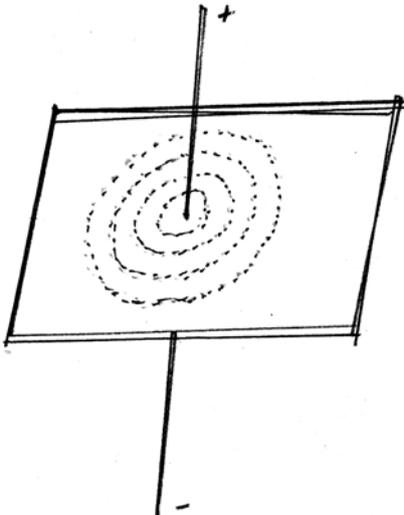

ഒരു ഇരുമ്പാണിയിൽ ചെമ്പ് കമ്പി ചുറ്റുക കമ്പിയുടെ ഒരറ്റം +ve ടെർമിനലിലും മറ്റെ അറ്റം -ve ടെർമിനലിലും ഘടിപ്പിക്കുക. കമ്പിക്ക് ചുറ്റും ഇരുമ്പ്പൊടി വിതറുക. അദ്ധ്യാപകൻ മേൽപറഞ്ഞ സന്ദർഭങ്ങളിൽ എന്താണ് ശരിയായ വസ്തുത എന്നും എന്തൊക്കെയാണ് കുട്ടിയുടെ വിശദീകരണത്തിന്റെ പോരായ്മ എന്നും ഉദാഹരണങ്ങളും കാരണങ്ങളും സഹിതം വിശദീകരിക്കുന്നു. ഇരുമ്പ്പൊടി കമ്പിയിലേക്ക് ആകർഷിക്കപ്പെടുന്നത് കാരണം, ഇത് വൈദ്യുതി പ്രവഹിക്കുമ്പോൾ കമ്പി കുഴപ്പമില്ലാതെ ഒരു കാന്തികമണ്ഡലം നിർമ്മിക്കപ്പെടുന്നതിനാലാണെന്ന് വിശദീകരിക്കുന്നു.

അദ്ധ്യാപകൻ താഴെ കൊടുത്തിരിക്കുന്ന ഉദാഹരണങ്ങൾ നൽകി പ്രസ്തുത സന്ദർഭത്തിൽ എന്താണ് നടക്കുക അല്ലെങ്കിൽ നടന്നിരിക്കുക എന്ന് കാര്യകാരണ സഹിതം പ്രവചിക്കാനോ അവ വിശദീകരിക്കാനോ ആവശ്യപ്പെടുന്നു.

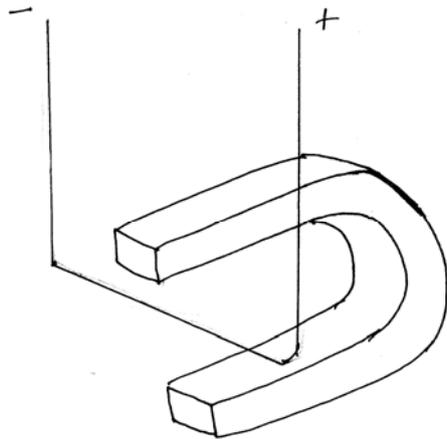

കുതിര ലാടത്തിന്റെ ആകൃതിയുള്ള കാന്തത്തിനിടയിലൂടെ ചിത്രത്തിൽ കാണുന്ന തരത്തിൽ വയർ ഘടിപ്പിക്കുക, വയർ ബാറ്ററിയുടെ ടെർമിനലുമായി ഘടിപ്പിക്കുക, വയർ ഒരു ദിശയിലേക്ക് ചലിക്കുന്നതായ് കാണാം, ബാറ്ററിയുടെ ടെർമിനലുകൾ മാറ്റി ഘടിപ്പിക്കുമ്പോൾ വയർ എതിർദിശയിലേക്ക് നീങ്ങുന്നതായും കാണാം. അധ്യാപകൻ മേൽപറഞ്ഞ സന്ദർഭങ്ങളിൽ എന്താണ് ശരിയായ വസ്തുത എന്നും എന്തൊക്കെയാണ് കുട്ടിയുടെ വിശദീകരണത്തിന്റെ പോരായ്മ എന്നും ഉദാഹരണങ്ങളും കാരണങ്ങളും സഹിതം വിശദീകരിക്കുന്നു. കമ്പിയിലൂടെ വൈദ്യുതി പ്രവഹിക്കുമ്പോൾ കാന്തികമണ്ഡലം ഉണ്ടാകുകയും അത് കാന്തത്തിന്റെ കാന്തികമണ്ഡലവുമായി സമ്പർക്കത്തിൽ വരുന്നതിനാലാണ് കമ്പിക്ക് ചലനം ഉണ്ടാവുന്നത് ഇതിൽ നിന്നും, വൈദ്യുത പ്രവാഹത്തിന് കാന്തിക മണ്ഡലം ഉണ്ടാക്കാൻ സാധിക്കും എന്ന് മനസിലാക്കാം.

പഠനപ്രവർത്തനങ്ങളിലൂടെ വൈദ്യുതകാന്തികപ്രേരണം എങ്ങിനെ നടക്കുന്നു എന്നും, കാന്തിക മണ്ഡലം സാധ്യമാവുന്നു എന്നും മനസിലാക്കുന്നു.

**LESSON PLAN - 7**

**Standard** : VIII  
**Topic** : സ്ഥിത വൈദ്യുതി  
**Strategy** : *Concept Map*  
**Time** : 2 periods

**ലക്ഷ്യങ്ങൾ** : ഉരസൽ മുഖേന വസ്തുക്കളെ ചാർജ്ജ് ചെയ്യാമെന്നും ചാർജ്ജുകൾക്ക് പരസ്പരം ആകർഷിക്കാനോ, വികർഷിക്കാനോ കഴിയും എന്നുള്ള അറിവും ധാരണയും നേടുന്നതിന്, കൺസപ്റ്റ് മാപ്പ് രൂപീകരിക്കുന്നതിന്.

**ആശയങ്ങൾ** : സ്ഥിതവൈദ്യുതി, ഇലക്ട്രോസ്കോപ്പ്, മിനൽ രക്ഷാചാലകം എർത്തിംഗ് തുടങ്ങിയവ

**സ്ഥിതവൈദ്യുതി**

തൂക്കിയിട്ടിരിക്കുന്ന രണ്ട് ബോളുകൾ തുകൽകൊണ്ടോ വൂൾകൊണ്ടോ റബ്ബർ ചെയ്യുക ഹാർഡ് റബ്ബർ കൊണ്ട് മാറിമാറി സ്പർശിക്കുക ബോളുകൾ രണ്ടും വികർഷിക്കപ്പെടുന്നു.

ഒരു ബോൾ റബ്ബർ കൊണ്ടും മറ്റേത് തുകൽകൊണ്ടും സ്പർശിക്കുക രണ്ട് ബോളുകളും ആകർഷിക്കപ്പെടുന്നു.

ഒരു ബോൾ തുകൽ ഉപയോഗിച്ച് ഉരസിയ ഹാർഡ് റബ്ബർ കൊണ്ടു രണ്ടാമത്തെ ബോൾ സിൽക്ക് കൊണ്ട് ഉരസിയ ഗ്ലാസ് റോഡ്കൊണ്ടും സ്പർശിക്കുക. ബോളുകൾ രണ്ടും ആകർഷിക്കപ്പെടും. ഇത് കാണിക്കുന്നത് അനുയോജ്യമായ ജോടികൾ തമ്മിൽ ഉരസുമ്പോൾ ഒന്നിൽ നിന്ന് മറ്റേതിലേക്ക് ഇലക്ട്രോണുകൾ കൈമാറ്റം ചെയ്യപ്പെടുന്നു. ഇലക്ട്രോണുകൾ ലഭിക്കുന്ന വസ്തുവിന് നെഗറ്റീവ് ചാർജ്ജും നഷ്ടപ്പെടുന്ന വസ്തുവിന് പോസിറ്റീവ് ചാർജ്ജും ലഭിക്കുന്നു. കൈമാറ്റം ചെയ്യപ്പെടുന്ന ചാർജ്ജ് വസ്തുവിൽ അതേ സ്ഥാനത്ത് നിൽക്കുന്നു. ഈ വൈദ്യുതിയെ സ്ഥിത വൈദ്യുതി (static electricity) എന്ന് പറയുന്നു.

ഗ്ലാസ് ദണ്ഡ് സിൽക്കുമായി ഉരസുമ്പോൾ ഗ്ലാസ് ദണ്ഡിൽ നിന്ന് ഇലക്ട്രോണുകൾ സിൽക്കിലേക്ക് മാറ്റപ്പെടുന്നു ഗ്ലാസ് റോഡ് പോസിറ്റീവ് ചാർജാകുന്നു.

ഗ്ലാസ് റോഡ് തുകലുമായി ഉരസുമ്പോൾ തുകലിൽ നിന്ന് ഗ്ലാസ് റോഡി-  
ലേക്ക് ഇലക്ട്രോണുകൾ മാറ്റപ്പെടുന്നു ഗ്ലാസ് റോഡ് നെഗറ്റീവ് ചാർജ് ആയി മാറ്റ-  
പ്പെടുന്നു.

വ്യത്യസ്തവും അനുയോജ്യവുമായ സ്വഭാവമുള്ള വസ്തുക്കൾ തമ്മിൽ ഉര-  
സുമ്പോൾ ചാർജ്ജ് കൈമാറ്റം ചെയ്യുകയും സ്ഥിതവൈദ്യുതി ഉണ്ടാവുകയും  
ചെയ്യും എന്ന് മനസ്സിലാക്കാം.

വുളൻ തുണികൊണ്ട് ഉരസിയ സ്പൂൺ ഒരു പൈപ്പിൽനിന്നു പ്രവഹിക്കുന്ന  
ജലധാരക്ക് സമീപത്തേക്ക് കൊണ്ട് വരുന്നു.

ജലപ്രവാഹം സ്പൂണിനടുത്തേക്ക് ആകർഷിക്കപ്പെടുന്നു. ഉരസുമ്പോൾ  
ചാർജ്ജ് ചെയ്യപ്പെടാത്ത ജലപ്രവാഹത്തെ ആകർഷിക്കുന്നു. ജലവും സ്പൂണും  
സ്പർശനത്തിൽ വരുമ്പോൾ ജലം ഇലക്ട്രിസിറ്റി കടത്തിവിടുന്നു. തത്ഫലമായി  
സ്പൂണിലെ ചാർജ്ജ് നഷ്ടപ്പെടുന്നു.

വായു നിറച്ച രണ്ട് ബലൂണുകൾ വുളൻ തുണിയിൽ ഉരസുക അവ അടു-  
ത്തേക്ക് കൊണ്ട് വരുമ്പോൾ പരസ്പരം വികർഷിക്കപ്പെടുന്നു ബലൂണുകൾ  
വുളിൽ ഉരസുമ്പോൾ നെഗറ്റീവ് ചാർജ്ജ് ശേഖരിക്കപ്പെടുന്നു. വുളിൽ നിന്ന് ഇലക്ര-  
ട്രോൺ ശേഖരിക്കപ്പെടുന്നു, വുളൻ തുണി പോസിറ്റീവ് ചാർജ്ജ് ആയി ചാർജ്ജ്  
ചെയ്യപ്പെടുന്നു. ബലൂണുകൾ വുളൻ വസ്ത്രത്തിൽ ഒട്ടിപിടിച്ചു നിൽക്കും കാരണം  
അത് വിപരീത ചാർജ്ജുകളാണ് വഹിക്കുന്നത്.

അനുയോജ്യമായ ജോടികൾ തമ്മിൽ ഉരസുമ്പോൾ ചാർജ്ജ് കൈമാറ്റം നട-  
ക്കുകയും സ്ഥിതവൈദ്യുതി ഉണ്ടാവുകയും ചെയ്യുമെന്ന് വിശദീകരിക്കുന്നു.

സ്ഥിതവൈദ്യുതി എന്താണെന്നും, മിന്നൽ രക്ഷാചാലകം, എർത്തിംഗ്  
എന്നിവ എന്താണെന്നും ധാരണ രൂപീകരിക്കുകയും കൺസപ്റ്റ് മാപ്പ് നിർമ്മിക്കു-  
കയും ചെയ്യുന്നു.

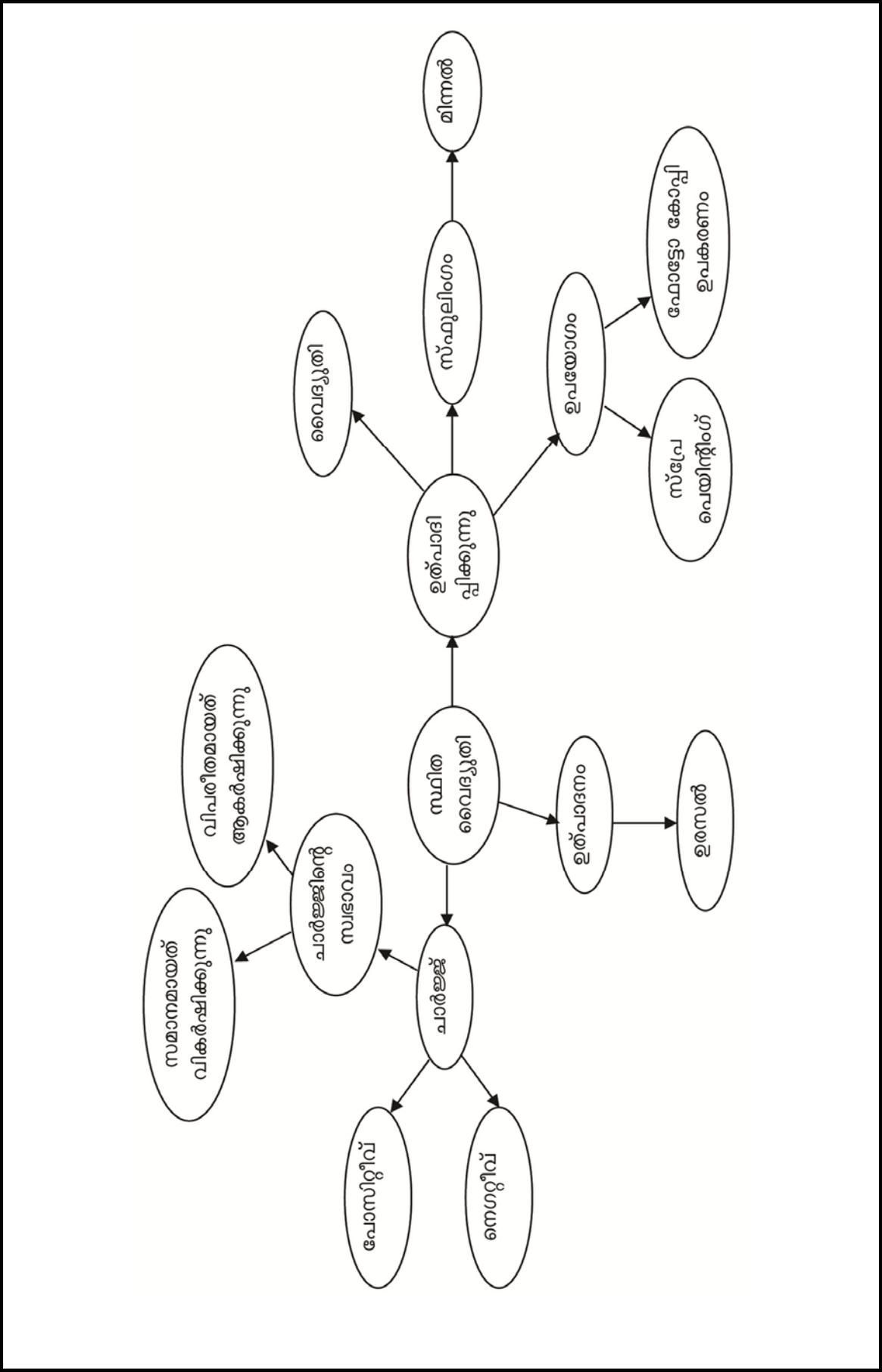

**LESSON PLAN - 8**

**Standard : VIII**  
**Topic : ജഡത്വം**  
**Strategy : Conceptual Change**  
**Time : 2 periods**

**ലക്ഷ്യങ്ങൾ :** ജഡത്വം എന്ന ആശയം രൂപീകരിക്കുന്നതിന് ചലന ജഡത്വം, നിശ്ചലജഡത്വം എന്നിവ മനസ്സിലാക്കുന്നതിന്, ജഡത്വം എങ്ങിനെ മാസുമായി ബന്ധപ്പെട്ടിരിക്കുന്നു എന്നതിനെക്കുറിച്ച് അറിയാൻ നിത്യജീവിതത്തിൽ ജഡത്വം എന്ന ആശം മുൻപിൽ വരുന്ന സന്ദർഭങ്ങളിൽ കണ്ടെത്തുന്നതിന്.

**ആശയങ്ങൾ :** മാസ്, ജഡത്വം.

**ജഡത്വം**

- Step 1 : ജഡത്വത്തെക്കുറിച്ച് പൊതുവായ മുൻധാരണകളും തെറ്റായ ധാരണകളും അധ്യാപകൻ കണ്ടെത്തി പട്ടികപ്പെടുത്തുന്നു.
- Step 2 : അധ്യാപകൻ നൽകുന്ന വ്യത്യസ്ത സന്ദർഭങ്ങളിൽ എന്താണ് സംഭവിക്കുക എന്ന് മുൻകൂട്ടി പ്രവചിക്കുവാനാവശ്യപ്പെടുന്നു.
- Step 3 : പൊതുവായ മുൻധാരണകളും തെറ്റിദ്ധാരണകളും കുട്ടികൾക്ക് തെളിവുകളുടെ അടിസ്ഥാനത്തിൽ എന്തുകൊണ്ട് തെറ്റാണെന്ന് താഴെ കൊടുത്ത പ്രവർത്തനങ്ങളിലൂടെ വിശദീകരിക്കുന്നു.
- Step 4 : അധ്യാപകൻ ശരിയായ ആശയങ്ങൾ വിശദീകരിച്ചു നൽകുന്നു.

**ജഡത്വം 1:**

അധ്യാപകൻ താഴെ കൊടുത്തിരിക്കുന്ന ഉദാഹരണങ്ങൾ നൽകി പ്രസ്തുത സന്ദർഭത്തിൽ എന്താണ് നടക്കുക അല്ലെങ്കിൽ നടന്നിരിക്കുക എന്ന് കാര്യകാരണ സഹിതം പ്രവചിക്കാനോ അവ വിശദീകരിക്കാനോ ആവശ്യപ്പെടുന്നു.

ഒരു കളിപ്പാട്ടലോറിയിൽ നിൽക്കുന്ന പാവയ്ക്ക് ഉണ്ടാകുന്ന മാറ്റം ജഡത്വം എന്താണെന്ന് വിശദീകരിക്കാൻ ഉപയോഗിക്കുന്നു.

നിൽക്കുന്ന പാവ ലോറി മുന്നോട്ടേക്ക് നീങ്ങുമ്പോൾ പിന്നോട്ടേക്ക് വീഴുന്നു. സഞ്ചരിച്ചുകൊണ്ടിരിക്കുന്ന ലോറി പെട്ടെന്ന് നിൽക്കുമ്പോൾ പാവ മുന്നോട്ടേക്ക് വീഴുന്നു. അധ്യാപകൻ മേൽപറഞ്ഞ സന്ദർഭങ്ങളിൽ എന്താണ് ശരിയായ വസ്തുത

എന്നും എന്തൊക്കെയാണ് കുട്ടിയുടെ വിശദീകരണത്തിന്റെ പോരായ്മ എന്നും ഉദാഹരണങ്ങളും കാരണങ്ങളും സഹിതം വിശദീകരിക്കുന്നു.

ഈ ഉദാഹരണങ്ങളിൽ നിന്നും ഒരു വസ്തുവിന് അതിന്റെ സ്ഥിരാവസ്ഥയിലോ നേർരേഖാപാതയിലൂടെയുള്ള സമചലനത്തിലോ തുടരാനുള്ള പ്രവണതയാണ് ജഡത്വം എന്ന് വിശദീകരിക്കുന്നു.

കൂടുതൽ ഉദാഹരണങ്ങൾ വിശദീകരിച്ച് നൽകുന്നു.

1. ഓടികൊണ്ടിരിക്കുന്ന ബസിൽ നിന്ന് യാത്രക്കാരുന് ചാടി ഇറങ്ങേണ്ടിവരുമ്പോൾ അല്പം മുമ്പോട്ട് ഓടേണ്ടതായ് വരുന്നു.
2. സ്വിച്ച് ഓഫ് ചെയ്ത ശേഷവും അല്പസമയം കൂടി ഫാൻ കറങ്ങുന്നത്.
3. അട്ടിയായ അടുക്കിയ 5 രൂപ കോയിനുകൾ അട്ടിതെറ്റിക്കാതെ അടിവശത്തെ കോയിൻ മാത്രം അടിച്ചുതെറുപ്പിക്കുന്നു.
4. ഗ്ലാസിന്റെ മുകളിൽ ചെറിയ, കട്ടിയുള്ള കടലാസു കഷണത്തിനു മുകളിൽ വെച്ചിരിക്കുന്ന കോയിൻ, കടലാസ് വിരൽകൊണ്ട് തെറിപ്പിക്കുമ്പോൾ ഗ്ലാസിനുള്ളിലേക്ക് വീഴുന്നു.

അദ്ധ്യാപകൻ താഴെ കൊടുത്തിരിക്കുന്ന ഉദാഹരണങ്ങൾ നൽകി പ്രസ്തുത സന്ദർഭത്തിൽ എന്താണ് നടക്കുക അല്ലെങ്കിൽ നടന്നിരിക്കുക എന്ന് കാര്യകാരണ സഹിതം പ്രവചിക്കാനോ അവ വിശദീകരിക്കാനോ ആവശ്യപ്പെടുന്നു.

ഒരു തൂണിയിൽ വെള്ളം നിറച്ച കപ്പും സോസറും വെയ്ക്കുക, വേഗത്തിൽ തൂണി വലിച്ചു മാറ്റുമ്പോൾ കപ്പിനോ സോസറിനോ ഒരു മാറ്റവും ഉണ്ടാവുന്നില്ല. അത് തത്സ്ഥാനത്ത് തുടരുന്നു. അദ്ധ്യാപകൻ മേൽപറഞ്ഞ സന്ദർഭങ്ങളിൽ എന്താണ് ശരിയായ വസ്തുത എന്നും എന്തൊക്കെയാണ് കുട്ടിയുടെ വിശദീകരണത്തിന്റെ പോരായ്മ എന്നും ഉദാഹരണങ്ങളും കാരണങ്ങളും സഹിതം വിശദീകരിക്കുന്നു. മുകളിൽ കൊടുത്തിരിക്കുന്ന ഉദാഹരണങ്ങളിൽ നിന്നും ജഡത്വം എന്താണെന്ന് മനസ്സിലാക്കുന്നു.

**ജഡത്ഥം 2**

അദ്ധ്യാപകൻ താഴെ കൊടുത്തിരിക്കുന്ന ഉദാഹരണങ്ങൾ നൽകി പ്രസ്തുത സന്ദർഭത്തിൽ എന്താണ് നടക്കുക അല്ലെങ്കിൽ നടന്നിരിക്കുക എന്ന് കാര്യകാരണ സഹിതം പ്രവചിക്കാനോ അവ വിശദീകരിക്കാനോ ആവശ്യപ്പെടുന്നു.

ഒരു സോസറിൽ വെള്ളം എടുക്കുക, പെട്ടെന്ന് സോസർ ഒരു വശത്തേക്ക് ചലിപ്പിക്കുക. അദ്ധ്യാപകൻ മേൽപറഞ്ഞ സന്ദർഭങ്ങളിൽ എന്താണ് ശരിയായ വസ്തുത എന്നും എന്തൊക്കെയാണ് കുട്ടിയുടെ വിശദീകരണത്തിന്റെ പോരായ്മ എന്നും ഉദാഹരണങ്ങളും കാരണങ്ങളും സഹിതം വിശദീകരിക്കുന്നു. അതുവരെ സ്ഥിരാവസ്ഥയിൽ നിലനിന്നിരുന്ന ജലം സോസർ മുന്നോട്ട് നീക്കിയപ്പോൾ പൂർവ്വ സ്ഥാനത്ത് തന്നെ തുടരുന്നു അതിനാൽ ജലം സോസറിൽ നിന്നും പിന്നോട്ടേക്ക് വീഴുന്നു.

അതേ സോസർ മെല്ലെ മുന്നോട്ട് ചലിപ്പിച്ച് വേഗത കൈവരിച്ച് പെട്ടെന്ന് നിർത്തുന്നു സഞ്ചരിച്ചുകൊണ്ടിരിക്കുന്ന ജലം മുന്നോട്ടുതന്നെ പോവുന്നതിനാൽ മുന്നോട്ടേക്ക് വീഴുന്നു.

അദ്ധ്യാപകൻ താഴെ കൊടുത്തിരിക്കുന്ന ഉദാഹരണങ്ങൾ നൽകി പ്രസ്തുത സന്ദർഭത്തിൽ എന്താണ് നടക്കുക അല്ലെങ്കിൽ നടന്നിരിക്കുക എന്ന് കാര്യകാരണ സഹിതം പ്രവചിക്കാനോ അവ വിശദീകരിക്കാനോ ആവശ്യപ്പെടുന്നു.

പുഴുങ്ങിയ കോഴിമുട്ടയും പച്ചമുട്ടയും മേശപുറത്ത്വെച്ച് ഓരോന്നായി കറക്കിവിടുക പുഴുങ്ങിയ മുട്ട ഒരു വിരൽ സ്പർശംകൊണ്ട് നിശ്ചലമാകുന്നു, എന്നാൽ പച്ചമുട്ട വിരൽ സ്പർശം മാറ്റുമ്പോൾ വീണ്ടും കറങ്ങുന്നു. അദ്ധ്യാപകൻ മേൽ പറഞ്ഞ സന്ദർഭങ്ങളിൽ എന്താണ് ശരിയായ വസ്തുത എന്നും എന്തൊക്കെയാണ് കുട്ടിയുടെ വിശദീകരണത്തിന്റെ പോരായ്മ എന്നും ഉദാഹരണങ്ങളും കാരണങ്ങളും സഹിതം വിശദീകരിക്കുന്നു. മുട്ടയുടെ ഉൾവശത്തുള്ള ദ്രാവകം ചലനാവസ്ഥയിൽ തന്നെ തുടരുന്നതിനാൽ ആണ് ഇത് സംഭവിക്കുന്നത്.

അദ്ധ്യാപകൻ താഴെ കൊടുത്തിരിക്കുന്ന ഉദാഹരണങ്ങൾ നൽകി പ്രസ്തുത സന്ദർഭത്തിൽ എന്താണ് നടക്കുക അല്ലെങ്കിൽ നടന്നിരിക്കുക എന്ന് കാര്യകാരണ സഹിതം പ്രവചിക്കാനോ അവ വിശദീകരിക്കാനോ ആവശ്യപ്പെടുന്നു.

മൂക്കാൽ ഭാഗം ജലം നിറച്ച ജഗ്ഗ് മേശപ്പുറത്തുകൂടെ വേഗത്തിൽ മുന്നോട്ടേക്ക് തള്ളിനീക്കുക. അധ്യാപകൻ മേൽപറഞ്ഞ സന്ദർഭങ്ങളിൽ എന്താണ് ശരിയായ വസ്തുത എന്നും എന്തൊക്കെയാണ് കുട്ടിയുടെ വിശദീകരണത്തിന്റെ പോരായ്മ എന്നും ഉദാഹരണങ്ങളും കാരണങ്ങളും സഹിതം വിശദീകരിക്കുന്നു. കൈ ജഗ്ഗിൽ നിന്ന് പിൻവലിക്കുമ്പോൾ ജഗ്ഗ് നിശ്ചലമാകുകയും എന്നാൽ ഉള്ളിലുള്ള ജലം സഞ്ചാരം തുടരുന്നതിനാൽ ജഗ്ഗ് മുന്നോട്ടേക്ക് നീങ്ങുകയും ചെയ്യുന്നു.

മുകളിൽ കൊടുത്തിരിക്കുന്ന ഉദാഹരണങ്ങളിൽ നിന്നും ജഡത്വം എന്താണെന്നും ചലന ജഡത്വം, നിശ്ചലജഡത്വം എന്താണെന്ന് മനസിലാക്കാൻ സഹായിക്കുന്നു.

ജഡത്വം എന്ന ആശയം പ്രയോഗത്തിൽ വരുന്ന നിത്യജീവിതത്തിലെ സന്ദർഭങ്ങൾ കണ്ടെത്തുകയും വർഗീകരിക്കുകയും ചെയ്യുന്നു.

**LESSON PLAN - 9**

**Standard : VIII**  
**Topic : സ്ഥാനാന്തരവും സഞ്ചരിച്ച ദൂരവും**  
**Strategy : Concept Map**  
**Time : 1 period**

**ലക്ഷ്യങ്ങൾ :** സദിശം, അദിശം എന്നീ ആശയങ്ങൾ രൂപപ്പെടുന്നതിന്  
 : സ്ഥാനാന്തരവും സഞ്ചരിച്ച ദൂരവും തിരിച്ചറിയുന്നതിന്  
**ആശയങ്ങൾ :** സദിശങ്ങളവുകൾ, അദിശങ്ങളവുകൾ, ദൂരം, സ്ഥാനാന്തരം, മുതലായവ.

**സ്ഥാനാന്തരവും സഞ്ചരിച്ച ദൂരവും**

സഞ്ചരിക്കുന്ന ഒരു വസ്തുവിന്റെ ആദ്യ സ്ഥാനവും അന്ത്യസ്ഥാനവും തമ്മിലുള്ള നേർരേഖാദൂരമാണ് സ്ഥാനാന്തരം.

ക്ലാസിലെ ജനലിലൂടെ ഒരു കഷണം ചോക്ക് പുറത്തേക്ക് ഇടുക, ആ ചോക്കു കഷണം ഒരു കുട്ടിയോട് ചെന്ന് എടുക്കാൻ ആവശ്യപ്പെടുക കുട്ടി ക്ലാസിന്റെ വാതിലിലൂടെ നടന്ന് ക്ലാസിന്റെ പിൻവശത്ത് ചെന്ന് ചോക്ക് എടുക്കുന്നു.

കുട്ടി സഞ്ചരിച്ച ദൂരവും, ക്ലാസിൽ നിന്ന് നേർരേഖയിൽ ചോക്കിനടുത്തേക്കുള്ള ദൂരവും തമ്മിലുള്ള വ്യത്യാസം വിശദീകരിക്കുന്നു.

കുട്ടി സഞ്ചരിച്ച മൊത്തം ദൂരം സഞ്ചരിച്ച ദൂരവും, കുട്ടിക്കുണ്ടായ സ്ഥാന വ്യത്യാസം ആദ്യത്തെ സ്ഥാനവും അവസാനത്തെ സ്ഥാനവും തമ്മിലുള്ള നേർരേഖാ വ്യത്യാസവുമാണെന്ന് മനസിലാക്കിക്കൊടുക്കുന്നു.

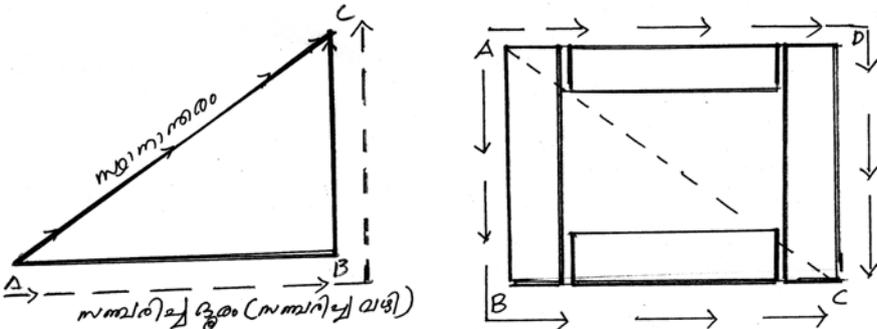

ചിത്രത്തിൽ കാണുന്ന തരത്തിൽ ക്ലാസ് മുറിയിൽ ബഞ്ചുകൾ ക്രമീകരിച്ച് കുട്ടികളോട് A യിൽ നിന്നും C യിലേക്ക് B വഴി ഒരു പുസ്തകം കൊണ്ടുപോയി വെയ്ക്കാൻ പറയുന്നു, പുസ്തകം സഞ്ചരിച്ച ദൂരവും പുസ്തകത്തിന്റെ സ്ഥാനാന്തരവും എന്താണെന്ന് വിശദമാക്കാൻ ആവശ്യപ്പെടുന്നു.

സ്ഥാനാന്തരവും സഞ്ചരിച്ച ദൂരവും തമ്മിലുള്ള വ്യത്യാസം എന്താണെന്ന് കൂടുതൽ ഉദാഹരണങ്ങൾകൊണ്ട് വിശദീകരിക്കാൻ ആവശ്യപ്പെടുന്നു.

മേൽപറഞ്ഞ പ്രവർത്തനങ്ങളിലൂടെ സ്ഥാനാന്തരവും, സഞ്ചരിച്ച ദൂരവും തമ്മിലുള്ള വ്യത്യാസം വേർതിരിച്ചറിയുകയും അവ ഉൾക്കൊള്ളിച്ച് കൺസപ്റ്റ് മാപ്പ് തയ്യാറാക്കുകയും ചെയ്യുന്നു. കുട്ടികൾ നിർമ്മിച്ച മാപ്പും, അധ്യാപകൻ തയ്യാറാക്കിയ മാപ്പും താരതമ്യം ചെയ്ത് അധ്യാപകൻ ആശയങ്ങൾ ക്രോഡീകരിക്കുന്നതിനും വ്യക്തത വരുത്തുന്നതിനും സഹായിക്കും.

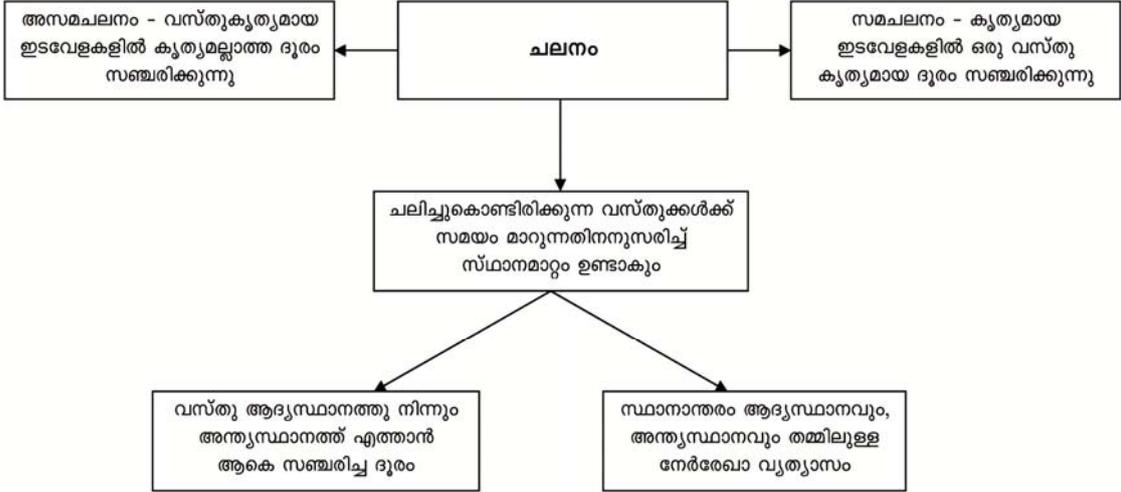

**LESSON PLAN - 10**

**Standard : VIII**  
**Topic : അപകേന്ദ്രബലം/അഭികേന്ദ്രബലം**  
**Strategy : Conceptual Change**  
**Time : 1 period**

**ലക്ഷ്യങ്ങൾ :** ബലം എന്ന ആശയം രൂപപ്പെടുന്നതിന്, അപകേന്ദ്രബലം/അഭികേന്ദ്രബലം എന്നിവ മനസ്സിലാക്കുന്നതിന്.  
**ആശയങ്ങൾ :** ബലം, ആന്തരികബലം, ബാഹ്യബലം, ബലത്തിന്റെ ദിശ, ത്വരണം, മുതലായവ.

**അപകേന്ദ്രബലം/അഭികേന്ദ്രബലം**

- Step 1 : അപകേന്ദ്രബലം/അഭികേന്ദ്രബലത്തെക്കുറിച്ച് പൊതുവായ മുൻധാരണകളും തെറ്റായ ധാരണകളും അധ്യാപകൻ കണ്ടെത്തി പട്ടികപ്പെടുത്തുന്നു.
- Step 2 : അധ്യാപകൻ നൽകുന്ന വ്യത്യസ്ത സന്ദർഭങ്ങളിൽ എന്താണ് സംഭവിക്കുക എന്ന് മുൻകൂട്ടി പ്രവചിക്കുവാനാവശ്യപ്പെടുന്നു.
- Step 3 : പൊതുവായ മുൻധാരണകളും തെറ്റിദ്ധാരണകളും കുട്ടികൾക്ക് തെളിവുകളുടെ അടിസ്ഥാനത്തിൽ എന്തുകൊണ്ട് തെറ്റാണെന്ന് താഴെ കൊടുത്ത പ്രവർത്തനങ്ങളിലൂടെ വിശദീകരിക്കുന്നു.
- Step 4 : അധ്യാപകൻ ശരിയായ ആശയങ്ങൾ വിശദീകരിച്ചു നൽകുന്നു.

അധ്യാപകൻ താഴെ കൊടുത്തിരിക്കുന്ന ഉദാഹരണങ്ങൾ നൽകി പ്രസ്തുത സന്ദർഭത്തിൽ എന്താണ് നടക്കുക അല്ലെങ്കിൽ നടന്നിരിക്കുക എന്ന് കാര്യകാരണ സഹിതം പ്രവചിക്കാനോ അവ വിശദീകരിക്കാനോ ആവശ്യപ്പെടുന്നു.

ഒരു ചെറിയ പ്ലാസ്റ്റിക് ബക്കറ്റിൽ മൂന്നിൽ രണ്ട് ഭാഗം വെള്ളം നിറക്കുക, ബക്കറ്റ് എടുത്ത് തലക്ക് മുകളിലൂടെ വൃത്തത്തിൽ കറക്കുക ജലം ബക്കറ്റിൽ നിന്നും പുറത്തു പോകാതെ നിൽക്കുന്നു.

അധ്യാപകൻ മേൽപറഞ്ഞ സന്ദർഭങ്ങളിൽ എന്താണ് ശരിയായ വസ്തുത എന്നും എന്തൊക്കെയാണ് കുട്ടിയുടെ വിശദീകരണത്തിന്റെ പോരായ്മ എന്നും ഉദാഹരണങ്ങളും കാരണങ്ങളും സഹിതം വിശദീകരിക്കുന്നു.

ജലം പുറത്തു പോകാതെ നിൽക്കാൻ കാരണം ജലം അപകേന്ദ്രബലം ബക്കറ്റിന്റെ അടിവശത്ത് പ്രയോഗിക്കുന്നത് കൊണ്ടാണെന്ന് വിശദീകരിക്കുന്നു. കറങ്ങുന്ന വേഗതയിൽ നിന്നാണ് അപകേന്ദ്രബലം ലഭ്യമാവുന്നതെന്നും വിശദീകരിക്കുന്നു.

ബക്കറ്റിന്റെ കറക്കത്തിന്റെ വേഗത കുറക്കുമ്പോൾ ജലം പുറത്തേക്ക് വീഴുന്നു കാരണം അപകേന്ദ്രബലം ഇല്ലാതാവുന്നു.

അദ്ധ്യാപകൻ താഴെ കൊടുത്തിരിക്കുന്ന ഉദാഹരണങ്ങൾ നൽകി പ്രസ്തുത സന്ദർഭത്തിൽ എന്താണ് നടക്കുക അല്ലെങ്കിൽ നടന്നിരിക്കുക എന്ന് കാര്യകാരണ സഹിതം പ്രവചിക്കാനോ അവ വിശദീകരിക്കാനോ ആവശ്യപ്പെടുന്നു.

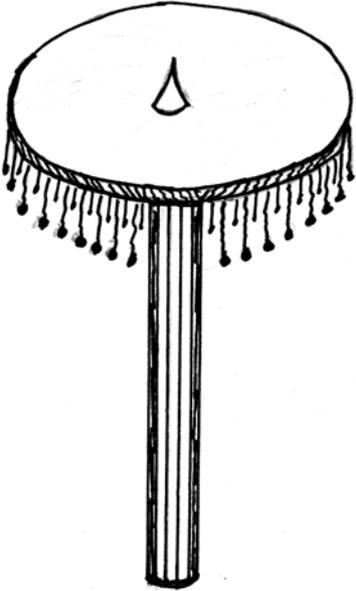

ചിത്രത്തിൽ കാണുന്ന തരത്തിലുള്ള കളിപ്പാട്ടം വേഗതയിൽ പ്രവർത്തിപ്പിക്കുമ്പോൾ. കളിപ്പാട്ടത്തിൽ തുങ്ങിനിൽക്കുന്ന ചെറിയ മുത്തുകൾ ദൂരത്തേക്ക് നീങ്ങുന്നു. അദ്ധ്യാപകൻ മേൽപറഞ്ഞ സന്ദർഭങ്ങളിൽ എന്താണ് ശരിയായ വസ്തുത എന്നും എന്തൊക്കെയാണ് കുട്ടിയുടെ വിശദീകരണത്തിന്റെ പോരായ്മ എന്നും ഉദാഹരണങ്ങളും കാരണങ്ങളും സഹിതം വിശദീകരിക്കുന്നു. അത് അപകേന്ദ്രബലം മൂലമാമെന്ന് കുട്ടികൾക്ക് വിശദീകരിച്ചുനൽകുന്നു.

ഒരു ബിന്ദു കേന്ദ്രീകരിച്ച് ഒരു വസ്തു ചുറ്റുമ്പോൾ വൃത്ത കേന്ദ്രത്തിൽ നിന്നും പുറത്തേക്ക് വസ്തുവിനുണ്ടാവുന്ന ബലമാണ്. അപകേന്ദ്രബലം.

അതുപോലെ വൃത്തകേന്ദ്രത്തിലേക്ക് വസ്തുവിനുണ്ടാവുന്ന ബലമാണ് അഭികേന്ദ്രബലം എന്ന് വളവുള്ള റോഡുകളിൽ വാഹനങ്ങളെ വളവിൽ നിന്നും പുറത്തേക്ക് തെറിച്ചുപോവാതെ പിടിച്ചുനിർത്താൻ സഹായിക്കുന്ന ബലത്തെ അഭികേന്ദ്രബലം എന്നും പറഞ്ഞ് മനസിലാക്കി നൽകുന്നു, വൃത്തകേന്ദ്രത്തിലേക്ക് അയിരിക്കും അഭികേന്ദ്രബലം പ്രവർത്തിക്കുക, സർക്കസിലെ മരകിണറിലെ ബൈക്ക് അഭ്യൂഹിക്ക് സ്ഥിരത നൽകുന്നത് അഭികേന്ദ്രബലമാണെന്ന് മനസിലാക്കാൻ സഹായിക്കുന്നു.

നൽകിയിരിക്കുന്ന പ്രവർത്തനത്തിന്റെ അടിസ്ഥാനത്തിൽ അപകേന്ദ്രബലം/അഭികേന്ദ്രബലം എന്നിവ വേർതിരിച്ചറിയുന്നതിനും. അവ ഉപയോഗത്തിൽ വരുന്ന സന്ദർഭങ്ങൾക്ക് ഉദാഹരണങ്ങൾ കണ്ടെത്തുകയും ചെയ്യുന്നു.

**LESSON PLAN - 11**

**Standard** : VIII  
**Topic** : ആകാശത്തിന്റെ നീല നിറത്തിന് കാരണമെന്ത്?  
**Strategy** : *Conceptual Change*  
**Time** : 1 period

**ലക്ഷ്യങ്ങൾ** : വിസരണം എന്ന പ്രതിഭാസത്തെക്കുറിച്ച് മനസ്സിലാക്കുന്നതിന് ദൃശ്യപ്രകാശത്തിലെ ഘടകവർണ്ണങ്ങൾ വിസരണത്തിന് വിധേയമാകുമ്പോൾ എന്തു സംഭവിക്കുന്നു എന്ന് മനസ്സിലാക്കുന്നതിന്.

**ആശയങ്ങൾ** : വിസരണം, വിസരണത്തിന്റെ തോത്.

**ആകാശത്തിന്റെ നീല നിറത്തിന് കാരണമെന്ത്?**

- Step 1 : ആകാശത്തിന്റെ നീല നിറത്തിന്റെ കാരണത്തെക്കുറിച്ച് പൊതുവായ മുൻധാരണകളും തെറ്റായ ധാരണകളും അധ്യാപകൻ കണ്ടെത്തി പട്ടികപ്പെടുത്തുന്നു.
- Step 2 : അധ്യാപകൻ നൽകുന്ന വ്യത്യസ്ത സന്ദർഭങ്ങളിൽ എന്താണ് സംഭവിക്കുക എന്ന് മുൻകൂട്ടി പ്രവചിക്കുവാനാവശ്യപ്പെടുന്നു.
- Step 3 : പൊതുവായ മുൻധാരണകളും തെറ്റിദ്ധാരണകളും കുട്ടികൾക്ക് തെളിവുകളുടെ അടിസ്ഥാനത്തിൽ എന്തുകൊണ്ട് തെറ്റാണെന്ന് താഴെ കൊടുത്ത പ്രവർത്തനങ്ങളിലൂടെ വിശദീകരിക്കുന്നു.
- Step 4 : അധ്യാപകൻ ശരിയായ ആശയങ്ങൾ വിശദീകരിച്ചു നൽകുന്നു.

ആകാശം പ്രകാശമയമായി കാണപ്പെടുന്നത് സ്കാറ്ററിങ്ങ് അഥവാ വിസരണം മൂലമാണ്, അന്തരീക്ഷത്തിലുള്ള വളരെ ചെറിയ പദാർത്ഥങ്ങൾ അഥവാ കണികകൾ ആണ് വിസരണത്തിന് കാരണം. ഈ ചെറു കണികകൾക്ക് വയലറ്റ് നിറത്തെ കൂടുതലായി വിസരണം നടത്താൻ കഴിവ് കൂടുതലുണ്ട്, നമ്മുടെ കണ്ണുകൾക്ക് വയലറ്റ് നിറത്തെ തിരിച്ചറിയുന്നതിൽ അത്ര കാര്യക്ഷമമല്ല അതിനാൽ കണ്ണ് പ്രകാശ സ്പെക്ട്രത്തിലെ അടുത്തനിരമായ നീല നിറത്തെ പെട്ടെന്ന് കൃത്യമായി മനസ്സിലാക്കാം അതുകൊണ്ട് വിസരണം ചെയ്യപ്പെടുന്ന നീലനിറം ആകാശത്തിന്റെ നിറമായി നമ്മൾ തിരിച്ചറിയുന്നു.

അദ്ധ്യാപകൻ താഴെ കൊടുത്തിരിക്കുന്ന ഉദാഹരണങ്ങൾ നൽകി പ്രസ്തുത സന്ദർഭത്തിൽ എന്താണ് നടക്കുക അല്ലെങ്കിൽ നടന്നിരിക്കുക എന്ന് കാര്യകാരണ സഹിതം പ്രവചിക്കാനോ അവ വിശദീകരിക്കാനോ ആവശ്യപ്പെടുന്നു.

ഒരു ഗ്ലാസ് ജാറിൽ ജലമെടുക്കുക അതിൽ കുറച്ച് തുള്ളി പാൽ ചേർക്കുക നന്നായി മിക്സ് ചെയ്യുക. ജാറിലൂടെ അപ്പുറം കാണുന്നതിൽ പ്രയാസം നേരിടുന്ന രീതിയിൽ പാൽ ചേർക്കുക.

ഒരു ഫ്ലാഷ് ലൈറ്റ് ജാറിന്റെ ഒരുവശത്ത് നിന്ന് പ്രകാശിപ്പിക്കുക. ജലത്തിലെ കണികകളിൽ തട്ടി പ്രകാശത്തിന് വിസരണം സംഭവിക്കുകയും ജലത്തിന്റെ കളറിൽ മാറ്റം സംഭവിക്കുകയും ചെയ്യുന്നു. അദ്ധ്യാപകൻ മേൽപറഞ്ഞ സന്ദർഭങ്ങളിൽ എന്താണ് ശരിയായ വസ്തുത എന്നും എന്തൊക്കെയാണ് കുട്ടിയുടെ വിശദീകരണത്തിന്റെ പോരായ്മ എന്നും ഉദാഹരണങ്ങളും കാരണങ്ങളും സഹിതം വിശദീകരിക്കുന്നു. ഇതിൽ നിന്നും പ്രകാശത്തിന്റെ വിസരണത്തിന്റെ പ്രക്രിയയും അതിൽ നിന്നും ആകാശത്തിന്റെ നിറം എങ്ങിനെയാണ് ഉണ്ടാവുന്നത് എന്നും മനസിലാക്കാൻ സഹായിക്കുന്നു.

ആകാശത്തിന്റെ നീലനിറം, വലിയ ജലാശയങ്ങളുടെ നീലനിറം, ആകാശത്തിന്റെ ചുവന്നനിറം എന്നിവ വിവിധ വർണ്ണങ്ങളുടെ വിസരണത്തിന് വിധേയമാകാനുള്ള കഴിവിനനുസരിച്ച് വിശദീകരിക്കുന്നു.

**LESSON PLAN - 12**

**Standard** : VIII  
**Topic** : ശബ്ദം ഉണ്ടാകുന്നത് കമ്പനം മൂലമാണ്  
**Strategy** : *Participative Approach*  
**Time** : 4 periods

**ലക്ഷ്യങ്ങൾ** : ശബ്ദത്തിന്റെ അടിസ്ഥാന ഗുണങ്ങൾ മനസിലാക്കുന്നതിന്, കമ്പനമാണ് ശബ്ദത്തിനാധാരം എന്നു തിരിച്ചറിയുന്നതിന്.  
**ആശയങ്ങൾ** : കമ്പനം, ദോലനം, ശബ്ദതരംഗം, ആവൃത്തി, ശ്രവണപരിധി.

**ശബ്ദം ഉണ്ടാകുന്നത് കമ്പനം മൂലമാണ്**

ശബ്ദം ഉണ്ടാവുന്നത് വസ്തുക്കൾ കമ്പനം ചെയ്യുമ്പോഴാണ് അഥവാ ശബ്ദം ഉണ്ടാവണമെങ്കിൽ വസ്തുക്കൾ കമ്പനം ചെയ്യണം. ശബ്ദം ഉണ്ടാവുന്നത് കമ്പനം മൂലമാണെന്ന് കുട്ടികൾക്ക് മനസിലാക്കാനായി ശബ്ദം ഉണ്ടാവുന്ന വിവിധ സന്ദർഭങ്ങൾ അനുഭവവേദ്യമാകുന്നു.

- 1) കുട്ടികൾ സംസാരിക്കുമ്പോൾ തൊണ്ടയിൽ വിൽ സ്പർശിച്ച് സ്വനപേടകം കമ്പനം ചെയ്യുന്നത് മനസിലാക്കുന്നു.
- 2) റേഡിയോ പ്രവർത്തിക്കുമ്പോൾ സ്പീക്കറിന്റെ ഉപരിതലം കമ്പനം ചെയ്യുന്നത് കാണുന്നു.
- 3) ഒരു നീളത്തിൽ ഉള്ള ചീർപ്പ് എടുത്ത് കട്ടിയുള്ള കാർഡ്കൊണ്ട് ചീർപ്പിന്റെ പല്ലുകൾ ഒരു വശത്തേക്ക് വേഗതയിൽ ചലിപ്പിക്കുക, ശബ്ദം ഉണ്ടാവുന്നു. ശബ്ദം ഉണ്ടായത് പല്ലുകൾ കമ്പനം ചെയ്താണെന്ന് മനസിലാക്കുന്നു.
- 4) ഒരു ലോഹ സ്കെയിൽ ബഞ്ചിന്റെ അറ്റത്ത് ഭൂരിഭാഗവും പുറത്തേക്കാക്കി പിടിച്ച് അറ്റത്ത് ശക്തമായി വിരൽകൊണ്ട് ബലം പ്രയോഗിച്ച് വിടുക സ്കെയിൽ കമ്പനം ചെയ്യുന്നു ശബ്ദമുണ്ടാകുകയും ചെയ്യുന്നു.
- 5) ഒരു ഇരുമ്പ് പൈപ്പ് ചരടിൽ തൂക്കി ഇടുന്നു, ഇരുമ്പ് ദണ്ഡ് ഉപയോഗിച്ച് പൈപ്പിൽ ചെറുതായ് അടിക്കുക. പൈപ്പ് കമ്പനം ചെയ്യാൻ തുടങ്ങുന്നു, ശബ്ദം ഉണ്ടാകുന്നത് കമ്പനത്താലാണെന്ന് മനസിലാക്കുന്നു. ഒരു പരന്ന പാത്രത്തിൽ ജലമെടുത്ത് താഴെനിന്നും പൈപ്പിന്റെ അഗ്രഭാഗം മുങ്ങുന്ന തരത്തിൽ ഉയർത്തുക, കമ്പനം ജലത്തിലേക്കും വ്യാപിപ്പിക്കുന്നത് കാണാം.

ശബ്ദം ഉണ്ടാകുന്നു, ശബ്ദം ഒരു മാധ്യമത്തിൽ നിന്നും മറ്റൊരു മാധ്യമത്തിലൂടെ സഞ്ചരിച്ചാണ് ശ്രവണബോധം ഉണ്ടാക്കുന്നതെന്ന് വിവരിച്ച് നൽകുന്നു.

6) ഒരു ട്യൂണിങ്ങ് ഫോർക്ക് കമ്പനം ചെയ്യുന്നത് ശബ്ദം ഉണ്ടാക്കുന്നതും വിവരിച്ച് നൽകുന്നു.

**ശബ്ദത്തിന്റെ പ്രസരണം**

ശബ്ദത്തിന് സഞ്ചരിക്കാൻ മാധ്യമം ആവശ്യമുണ്ട് എന്ന് മനസിലാക്കാനും വിവിധ മാധ്യമങ്ങളിലൂടെ സഞ്ചരിക്കും എന്ന് തെളിയിക്കാനും.

- ▶ ഒരു സ്പൂണിന്റെ അറ്റം ഒരു ചരടിന്റെ മധ്യഭാഗത്തായി കെട്ടുക ചരടിന്റെ രണ്ടറ്റവും രണ്ട് കൈകൊണ്ട് വലിച്ചു പിടിക്കുക. സ്പൂൺ പതുക്കെ മേശയിലോ മറ്റോ തട്ടിക്കുക. വലിച്ചു നിർത്തിയ രണ്ട് അഗ്രങ്ങളും ചെവിയിൽ ചേർത്ത് വെക്കുക. ശബ്ദം കേൾക്കുന്നതായ് അനുഭവപ്പെടുന്നു.
- ▶ ചരടിന്റെ രണ്ട് അറ്റത്തും ഓരോ പെൻസിലുകൾ കെട്ടുക എന്നിട്ട് മേൽപറഞ്ഞ പ്രവർത്തനം ആവർത്തിക്കുക. വീണ്ടും ശബ്ദം കേൾക്കുന്നു ഇതിൽ നിന്നും ശബ്ദത്തിന് സഞ്ചരിക്കാൻ മാധ്യമം ആവശ്യമാണെന്ന് വിശദീകരിക്കുന്നു.
- ▶ രണ്ട് പ്ലാസ്റ്റിക് കപ്പുകൾ ചരുകൊണ്ട് ബന്ധിപ്പിച്ച് ഒന്ന് കുട്ടികളിലൊരാളുടെ ചെവിയിൽ വയ്ക്കാൻ പറയുന്നു മറ്റേ കപ്പിൽ ടെലിഫോണിൽ സംസാരിക്കുന്നത് പോലെ കുട്ടികളിലൊരാളോട് സംസാരിക്കാൻ ആവശ്യപ്പെടുന്നു, ശബ്ദം ചരടിലൂടെ സഞ്ചരിച്ച് കപ്പിൽ എത്തി കേൾക്കാൻ സാധിക്കുന്നു; ചരടിന്റെ മധ്യഭാഗം മുറിച്ച് ഒരു മരക്കഷണവുമായി ചരടിന്റെ രണ്ടറ്റങ്ങളും ബന്ധിപ്പിക്കുക. വീണ്ടും കപ്പിലൂടെ സംസാരിക്കാൻ ആവശ്യപ്പെടുന്നു, മറ്റേ കപ്പിൽ ചെവി വെക്കുമ്പോൾ കേൾക്കാൻ സാധിക്കുന്നു, ശബ്ദം ചരടിൽ നിന്നും മരംവഴി കപ്പിൽ എത്തുന്നു. മൂന്ന് വ്യത്യസ്ത വസ്തുക്കളിലൂടെ സഞ്ചരിച്ചാണ് ശബ്ദം ചെവിയിൽ എത്തിയതെന്നും ശബ്ദത്തിന് സഞ്ചരിക്കാൻ മാധ്യമം ആവശ്യമാണെന്നും മനസിലാക്കാൻ സഹായിക്കുന്നു.

ശബ്ദം ഉണ്ടാകുന്നത് കമ്പനം മൂലമാണെന്നും, ശബ്ദത്തിന്റെ പ്രസരണം നടക്കുന്നത് വിവിധ മാധ്യമങ്ങൾ വഴിയാണെന്നും മനസിലാക്കുകയും ആശയങ്ങൾ ക്രോഡീകരിക്കുകയും ചെയ്യുന്നു.

**LESSON PLAN - 13**

**Standard : VIII**  
**Topic : പ്രകാശത്തിലെ വിവിധ വർണ്ണങ്ങൾ**  
**Strategy : Conceptual Change**  
**Time : 1 period**

**ലക്ഷ്യങ്ങൾ :** ദൃശ്യപ്രകാശം വർണ്ണനിർമ്മിതമാണെന്ന ധാരണ ഉറപ്പിക്കുന്നതിന്, പ്രകാശവർണ്ണങ്ങളെക്കുറിച്ച് ശരിയായി അറിയുന്നതിന്.  
**ആശയങ്ങൾ :** പ്രകീർണ്ണം, ഘടകവർണ്ണങ്ങൾ, പ്രാഥമികവർണ്ണങ്ങൾ, ദ്വിതീയ വർണ്ണങ്ങൾ

**പ്രകാശത്തിലെ വിവിധ വർണ്ണങ്ങൾ**

- Step 1 : പ്രകാശത്തിന്റെ വിവിധ വർണ്ണങ്ങളെക്കുറിച്ച് പൊതുവായ മുൻധാരണകളും തെറ്റായ ധാരണകളും അധ്യാപകൻ കണ്ടെത്തി പട്ടികപ്പെടുത്തുന്നു.
- Step 2 : അധ്യാപകൻ നൽകുന്ന വ്യത്യസ്ത സന്ദർഭങ്ങളിൽ എന്താണ് സംഭവിക്കുക എന്ന് മുൻകൂട്ടി പ്രവചിക്കുവാനാവശ്യപ്പെടുന്നു.
- Step 3 : പൊതുവായ മുൻധാരണകളും തെറ്റിദ്ധാരണകളും കുട്ടികൾക്ക് തെളിവുകളുടെ അടിസ്ഥാനത്തിൽ എന്തുകൊണ്ട് തെറ്റാണെന്ന് താഴെ കൊടുത്ത പ്രവർത്തനങ്ങളിലൂടെ വിശദീകരിക്കുന്നു.
- Step 4 : അധ്യാപകൻ ശരിയായ ആശയങ്ങൾ വിശദീകരിച്ചു നൽകുന്നു.

അധ്യാപകൻ താഴെ കൊടുത്തിരിക്കുന്ന ഉദാഹരണങ്ങൾ നൽകി പ്രസ്തുത സന്ദർഭത്തിൽ എന്താണ് നടക്കുക അല്ലെങ്കിൽ നടന്നിരിക്കുക എന്ന് കാര്യകാരണ സഹിതം പ്രവചിക്കാനോ അവ വിശദീകരിക്കാനോ ആവശ്യപ്പെടുന്നു.

ഒരു സോപ്പുകുമിള ഗ്ലാസിന്റെ അറ്റത്ത് ഉറപ്പിച്ച് നിർത്തുക സമീപത്തായ് ഒരു മെഴുകുതിരി കത്തിച്ചു വെക്കുക, എതിർവശത്തായ് സോപ്പ് കുമിള മധ്യത്തിൽ വരത്തക്കവിധം ഒരു വെള്ള പേപ്പർ സ്ഥാപിക്കുക പ്രകാശത്തിലെ വിവിധ നിറങ്ങൾ പേപ്പറിൽ പ്രതിഫലിക്കുന്നത് കാണാം. അധ്യാപകൻ മേൽപറഞ്ഞ സന്ദർഭങ്ങളിൽ എന്താണ് ശരിയായ വസ്തുത എന്നും എന്തൊക്കെയാണ് കുട്ടിയുടെ വിശദീകരണത്തിന്റെ പോരായ്മ എന്നും ഉദാഹരണങ്ങളും കാരണങ്ങളും സഹിതം വിശദീകരിക്കുന്നു. ഇതിൽ നിന്നും ധവളപ്രകാശം എന്നത് വിവിധ വർണ്ണങ്ങൾ ചേർന്നതാണെന്ന് മനസ്സിലാക്കാം.

അധ്യാപകൻ താഴെ കൊടുത്തിരിക്കുന്ന ഉദാഹരണങ്ങൾ നൽകി പ്രസ്തുത സന്ദർഭത്തിൽ എന്താണ് നടക്കുക അല്ലെങ്കിൽ നടന്നിരിക്കുക എന്ന് കാര്യകാരണ സഹിതം പ്രവചിക്കാനോ അവ വിശദീകരിക്കാനോ ആവശ്യപ്പെടുന്നു.

രണ്ട് ടോർച്ചുകൾ എടുത്ത് രണ്ട് വ്യത്യസ്ത നിറത്തിലുള്ള ഗ്ലാസ് പേപ്പറുകൾ ഘടിപ്പിച്ച് ടോർച്ചിലെ പ്രകാശം വെളുത്ത പേപ്പറിൽ പതിപ്പിക്കുക. എവിടെയാണോ രണ്ട് പ്രകാശധാരകളും ചേർന്ന് പതിക്കുന്നത് അവിടെ നിറത്തിന് വ്യത്യാസം വരുന്നതായ്കാണാം.

മൂന്നാമതൊരു ടോർച്ച് എടുത്ത് മൂന്ന് ടോർച്ചുകളിലായ് പ്രാഥമികനിറങ്ങൾ ഘടിപ്പിക്കുക എന്നിട്ട് പ്രകാശം വെളുത്ത പേപ്പറിൽ പതിപ്പിക്കുക. മൂന്ന് നിറങ്ങളും കൂടി ചേരുമ്പോൾ വെളുത്ത നിറമായി മാറുന്നത് കാണാം.

അധ്യാപകൻ മേൽപറഞ്ഞ സന്ദർഭങ്ങളിൽ എന്താണ് ശരിയായ വസ്തുത എന്നും എന്തൊക്കെയാണ് കുട്ടിയുടെ വിശദീകരണത്തിന്റെ പോരായ്മ എന്നും ഉദാഹരണങ്ങളും കാരണങ്ങളും സഹിതം വിശദീകരിക്കുന്നു.

മേൽ വിവിരിച്ച പ്രവർത്തനങ്ങളിലൂടെ ധവളപ്രകാശത്തിന്റെ ഘടകവർണ്ണങ്ങളെക്കുറിച്ച് മനസിലാക്കുന്നു.

**LESSON PLAN -14**

**Standard : VIII**  
**Topic : അപവർത്തനം**  
**Strategy : Conceptual Change**  
**Time : 1 period**

**ലക്ഷ്യങ്ങൾ :** അപവർത്തനം എന്ന ആശയം മനസിലാക്കുന്നതിന്, വിവിധ മാധ്യമങ്ങളിലൂടെ സഞ്ചരിക്കുമ്പോൾ പ്രകാശത്തിന്റെ പാതയ്ക്കുള്ള വ്യതിയാനം മനസിലാക്കുന്നതിന്.

**ആശയങ്ങൾ :** അപവർത്തനം, പ്രകാശവീഥി, വിവിധ മാധ്യമങ്ങൾ, പ്രതിഫലനം, മാധ്യമങ്ങളുടെ സാന്ദ്രത വ്യത്യാസം.

**അപവർത്തനം**

- Step 1 : അപവർത്തനത്തിന്റെ കാരണത്തെക്കുറിച്ച് പൊതുവായ മുൻധാരണകളും തെറ്റായ ധാരണകളും അധ്യാപകൻ കണ്ടെത്തി പട്ടികപ്പെടുത്തുന്നു.
- Step 2 : അധ്യാപകൻ നൽകുന്ന വ്യത്യസ്ത സന്ദർഭങ്ങളിൽ എന്താണ് സംഭവിക്കുക എന്ന് മുൻകൂട്ടി പ്രവചിക്കുവാനാവശ്യപ്പെടുന്നു.
- Step 3 : പൊതുവായ മുൻധാരണകളും തെറ്റിദ്ധാരണകളും കുട്ടികൾക്ക് തെളിവുകളുടെ അടിസ്ഥാനത്തിൽ എന്തുകൊണ്ട് തെറ്റാണെന്ന് താഴെ കൊടുത്ത പ്രവർത്തനങ്ങളിലൂടെ വിശദീകരിക്കുന്നു.
- Step 4 : അധ്യാപകൻ ശരിയായ ആശയങ്ങൾ വിശദീകരിച്ചു നൽകുന്നു.

അധ്യാപകൻ താഴെ കൊടുത്തിരിക്കുന്ന ഉദാഹരണങ്ങൾ നൽകി പ്രസ്തുത സന്ദർഭത്തിൽ എന്താണ് നടക്കുക അല്ലെങ്കിൽ നടന്നിരിക്കുക എന്ന് കാര്യകാരണ സഹിതം പ്രവചിക്കാനോ അവ വിശദീകരിക്കാനോ ആവശ്യപ്പെടുന്നു.

ഒരു കോയിൻ ഒരു പാത്രത്തിന്റെ അടിവശത്ത് ഒട്ടിച്ച് വെക്കുക. കുട്ടിയോട് പാത്രത്തിന്റെ അരികിലൂടെ കോയിൻ കാണുന്ന തരത്തിൽ നോക്കാൻ ആവശ്യപ്പെടുന്നു, കുട്ടിയോട് ഒരു സ്റ്റേപ്പ് പിന്നോട്ട് നീങ്ങിനിൽക്കാൻ ആവശ്യപ്പെടുന്നു (കോയിനിന്റെ അഗ്രം കഷ്ടിച്ച് കാണാൻ സാധിക്കുന്ന തരത്തിൽ).

പാത്രത്തിലേക്ക് കുറച്ച് ജലം സാവധാനം ഒഴിക്കുക, കുറച്ച് ജലം ഒഴിച്ചു കഴിയുമ്പോൾ കോയിൻ കാണുവാൻ സാധിക്കുന്നു. കാരണമെന്തെന്ന് വിശദീകരിക്കുന്നു.

ക്കുന്നു. അധ്യാപകൻ മേൽപറഞ്ഞ സന്ദർഭങ്ങളിൽ എന്താണ് ശരിയായ വസ്തുത എന്നും എന്തൊക്കെയാണ് കുട്ടിയുടെ വിശദീകരണത്തിന്റെ പോരായ്മ എന്നും ഉദാഹരണങ്ങളും കാരണങ്ങളും സഹിതം വിശദീകരിക്കുന്നു.

അധ്യാപകൻ താഴെ കൊടുത്തിരിക്കുന്ന ഉദാഹരണങ്ങൾ നൽകി പ്രസ്തുത സന്ദർഭത്തിൽ എന്താണ് നടക്കുക അല്ലെങ്കിൽ നടന്നിരിക്കുക എന്ന് കാര്യകാരണ സഹിതം പ്രവചിക്കാനോ അവ വിശദീകരിക്കാനോ ആവശ്യപ്പെടുന്നു.

- ▶ ഒരു ഗ്ലാസ് പാത്രത്തിലെ ജലത്തിലേക്ക് പെൻസിലൊ, റുളറോ ഇറക്കി വെയ്ക്കുക, പെൻസിൽ വളഞ്ഞിരിക്കാത്തതായ് കാണപ്പെടുന്നു കാരണമെന്തെന്ന് മുകളിലുള്ള പ്രവർത്തനത്തിന്റെ കൂടെ സഹായത്താൽ വിശദീകരിക്കുന്നു.
- ▶ ഒരു വെളുത്ത പേപ്പറിൽ നീളത്തിൽ ഒരു രേഖ വരയ്ക്കുക. ഒരു ഗ്ലാസ് ബോട്ടിലിൽ വെള്ളം നിറച്ച് രേഖയിൽ വെക്കുക. നേർരേഖ ബോട്ടിൽ വെച്ച ഭാഗത്ത് മുറിഞ്ഞു കാണുന്നു കാരണമെന്തെന്നു വിവരിക്കുന്നു.

പ്രകാശം വസ്തുക്കളിൽ നിന്നും പ്രതിഫലിച്ച് കണ്ണുകളിൽ എത്തുമ്പോഴാണ് കാഴ്ച സാധ്യമാവുന്നത്, കണ്ണിൽ എത്തുന്നത് പ്രകാശം വിവിധ മാധ്യമങ്ങളിലൂടെ സഞ്ചരിച്ചാണ് എന്ന് വിശദീകരിക്കുന്നു, പാത്രത്തിലെ കോയിനിൽ നിന്ന് പ്രകാശം കണ്ണിലെത്തുന്നതിന് മുൻപേ ജലം, വായു എന്നീ മാധ്യമത്തിലൂടെ സഞ്ചരിക്കുന്നു, പേപ്പറിലെ വരയിൽ നിന്നും പ്രതിഫലിപ്പിക്കുന്ന പ്രകാശം ഗ്ലാസ്, ജലം, വായു എന്നീ മാധ്യമങ്ങളിലൂടെ സഞ്ചരിച്ചാണ് കണ്ണിൽ എത്തുന്നത്, പ്രകാശം ഒരു മാധ്യമത്തിൽ നിന്ന് മറ്റൊരു മാധ്യമത്തിലേക്ക് കടക്കുമ്പോൾ അതിന്റെ പാതക്ക് വ്യതിയാനം സംഭവിക്കുന്നു അതിനാലാണ് പേപ്പറിലെ വര മുറിഞ്ഞു കണ്ടതും, പാത്രത്തിലോ കോയിൻ കാണുവാൻ സാധിച്ചതും പെൻസിൽ വളഞ്ഞു കാണപ്പെടതും എന്ന് വിശദീകരിക്കുന്നു.

മേൽപറഞ്ഞ പ്രവർത്തനങ്ങളിൽ നിന്നും അപവർത്തനം എന്ന ആശയം മനസ്സിലാക്കുകയും പരിസരങ്ങളിൽ കണ്ടെത്താവുന്ന അപവർത്തനം സന്ദർഭങ്ങൾ കണ്ടെത്തുകയും ചെയ്യുന്നു.

UNIVERSITY OF CALICUT  
DEPARTMENT OF EDUCATION

INSTRUCTIONAL PROGRAMMES  
FOR REMEDIATION OF MISCONCEPTS

**Dr. K. Abdul Gafoor**  
Associate Professor

**Akhilesh, P.T.**  
Research Scholar

---

**LESSON PLAN – 1**

---

**Standard** : VIII

**Topic** : Newton's Laws of Motions

**Strategy** : *Concept Map Along with Conceptual Change*

**Time** : 4 periods

---

**Objectives** : To make the students aware of Newton's Laws of Motion through experience and simple experiments and apply them at various life situations.

**Concepts** : Force, Internal Force, Mass, Acceleration, action, reaction.

Step 1 : Teacher categorizes the common preconceptions and misconceptions about laws of motion.

Step 2 : Asking students to predict what will happen in the situation given by teacher.

Step 3 : Preconceptions and misconceptions are getting cleared with the help of different activities

Step 4 : Teacher explains 'Concepts'- A body continues to in its state of rest or uniform motion until it is compelled by an external agency (force)

### **Pre-requisites**

- Force can change the state of motion of the body.
- Knowledge about uniform motion, non-uniform motion, velocity, acceleration, uniform acceleration

### **Newton's First Law of Motion**

A body continues in its state of rest or uniform motion until it is compelled by an external agency.

Students uses Newton's three laws differently and identifies incorrectly at various situations. To change the misconception teacher provides 3 different situations.

Teacher introduces the following situations to students and ask to predict what will be the result and its reasons.

→ Allow a metallic sphere to slide along an inclined plane with different angles of inclination. Measure the distance covered by sphere in each situation.

- Why does the sphere cover different distances at different inclinations?
- Does the plane apply any force or reaction against the movements of sphere?

Teacher contrast children's ideas with the right explanations and give the idea that,

To stop a moving object external force is necessary which is shown by demonstration. The teacher stopped a rolling ball. From this students are

guided to understand that rolling spheres at various inclinations and stopped by the surface of inclination. The force applied by surface against motion differs with inclination.

### **Newton's Second Law of Motion**

The rate of change of momentum of a body is equivalent to the applied external force and is in the direction of force.

Teacher gives different examples and introduces the following situations to students and ask to predict what will be the result and its reasons.

→ Cricket player drags arms behind while taking catch

→ While catching the cement vessel by labourers, they catch the vessel and suddenly drag hands behind.

Why such actions of 'dragging hands' happens? Teacher asks to pupils.

Teacher contrast childrens ideas with the right explanations and give the idea,

Teacher gives balls of different masses. Throws them at different speeds to children and asks them to catch it with and without dragging hands back. Children experiences different impacts made by the moving balls of various masses and speed and understands that mass-speed and momentum are related.

→ Firing bullet can produce greater impact than throwing it.

→ Accident between an Auto causes less impact on car than a bus and the direction of change in momentum is in direction of force.

### Newton's Third Law of Motion

Teacher introduces the following situations to students and ask to predict what will be the result and its reasons.

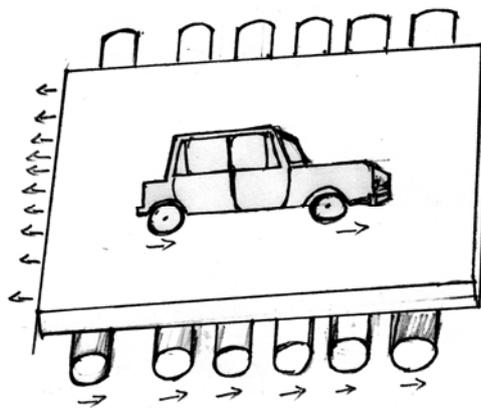

→ Operates a toy car working on the principle of potential energy placed on a wooden board. The whole arrangement is kept on parallelly arranged cylindrical sticks (log) as in figure. As the car moves forward the wooden board moves backwards and hence the logs move to opposite direction.

Teacher contrast childrens ideas with the right explanations and give the ideas,

It is inferred from that the movement of car in forward direction applies a force on wooden board so that board moves backward. These moving board exerts a force in opposite direction on logs and hence the logs experience a motion to the opposite to that of the board.

→ When jumping from a boat to shore, boat will moves to opposite direction of jumping.

→ Suddenly opened balloon will propelled against the direction of air current.

→ Rocket propulsion is due to the air current in opposite direction.

Using these examples teacher explains that for every action there is an equal and opposite reaction and asks students to list daily life experience in their science diary.

Teacher introduces the following situations to students and ask to predict what will be the result and its reasons.

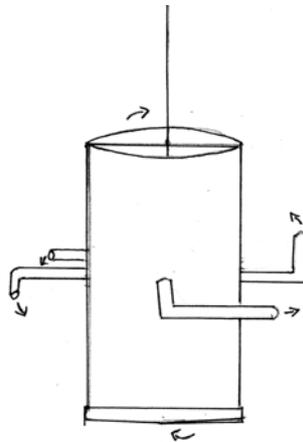

→ As in Figure (2) connect straws in 'L' shape to PVC pipe. Keep one end of the pipe as opened and the other closed. Fill the pipe with water. Suddenly water gushes through straws and the pipe starts to rotate against the direction of current.

Teacher contrast childrens ideas with the right explanations and give the ideas,

The 'action' during current caused a 'reaction' in pipe, so as to move in opposite direction of current flow.

Teacher introduces the following situations to students and ask to predict what will be the result and its reasons.

→ Cover few matchsticks in a news paper as shown in figure 3 hang it in air when it fired what will happen.

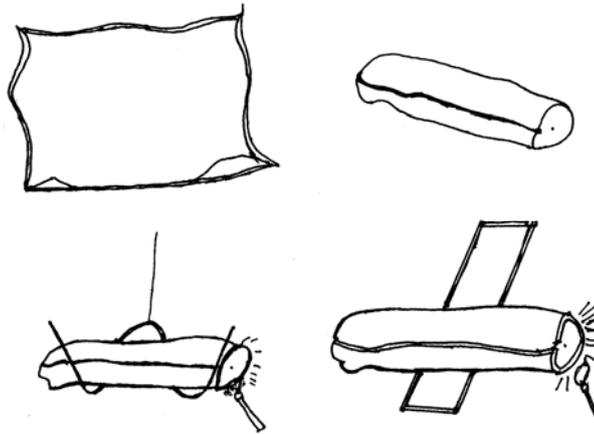

Teacher contrast childrens ideas with the right explanations and give the idea that,

Abrupt fire will cause the paper cover to move outward. The direction of motion of paper cover is against the direction of firing.

From all these examples Newton's third law is conveyed explicitly.

As per the help of examples given to learn Newton's laws of motion students were asked to draw concept maps for laws of motion. Finally teacher corrects and explains map well.

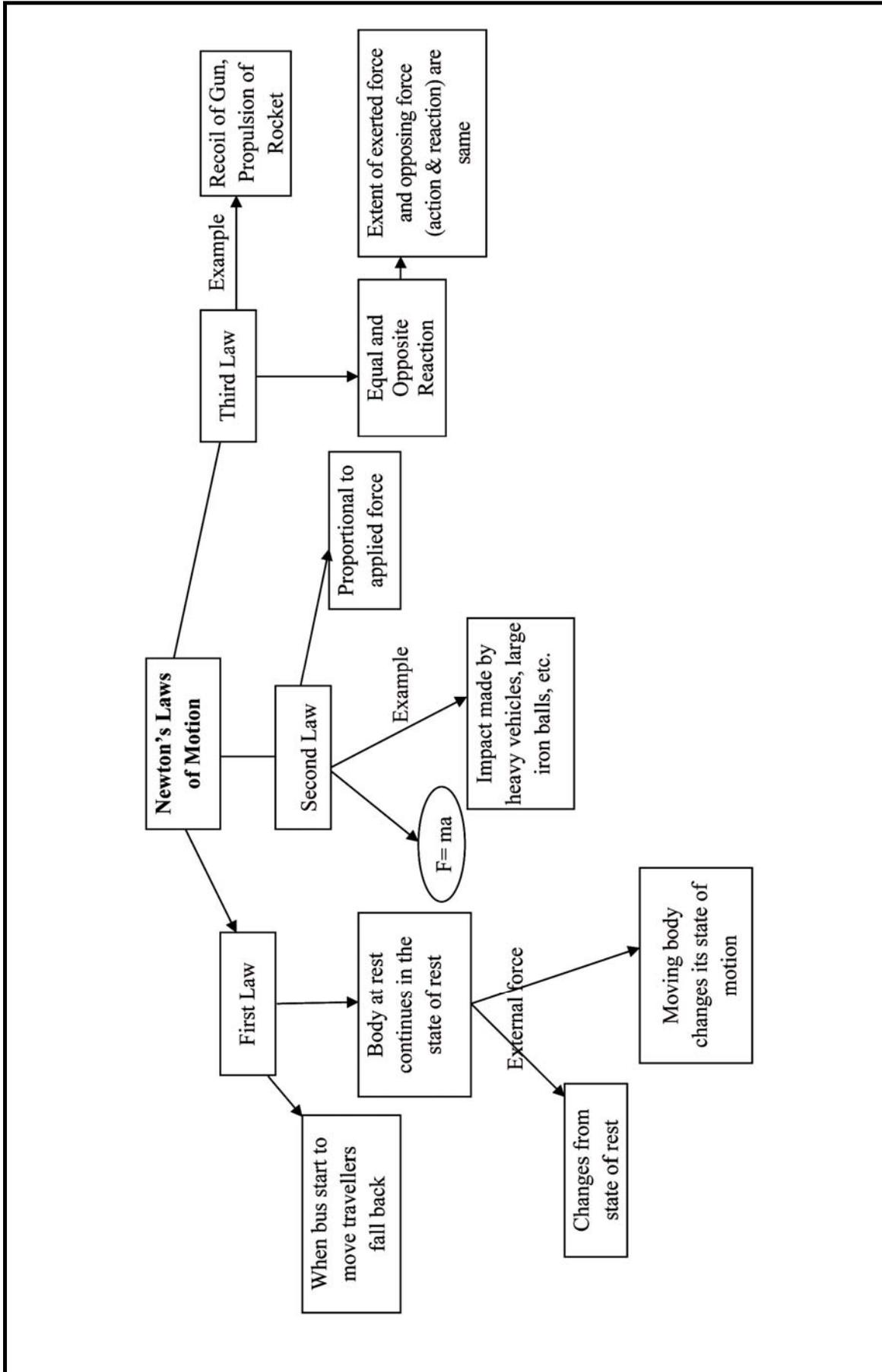

**LESSON PLAN – 2**

---

**Standard** : VIII  
**Topic** : Pascal's Law  
**Strategy** : *Concept Map*  
**Time** : 1 period

---

**Objectives** : To understand the diffusion of pressure in liquid and to make students able to prepare concept maps.

**Concepts** : Pressure, diffusion

**Pascal's Law**

Pressure applied to a liquid at rest, it will spread equally through out the liquid.

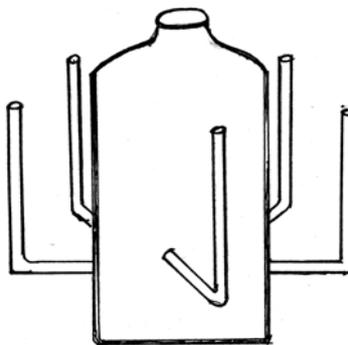

→ As shown in figure fix six straws in L shape in the middle part of a transparent bottle. Then pour water in the bottle so that every straw shows equal water level. Blow air strongly through the open end of bottle; water will gush equally through straws. Because the pressure applied to one end of bottle spreads equally in all portions of including water in straws hence it gets displaced. Instead of water in bottle fix an empty balloons in the tips of

each straw and then blow the air strongly. It can see that every balloon gets filled with air equally.

→ Try to explain why toothpaste coming out of the tube while pressing anywhere on the tube.

Children familiarizes various experiments and situations to understand Pascal's law and trying to prepare concept map. Teacher explains the law well and then corrects the concept maps.

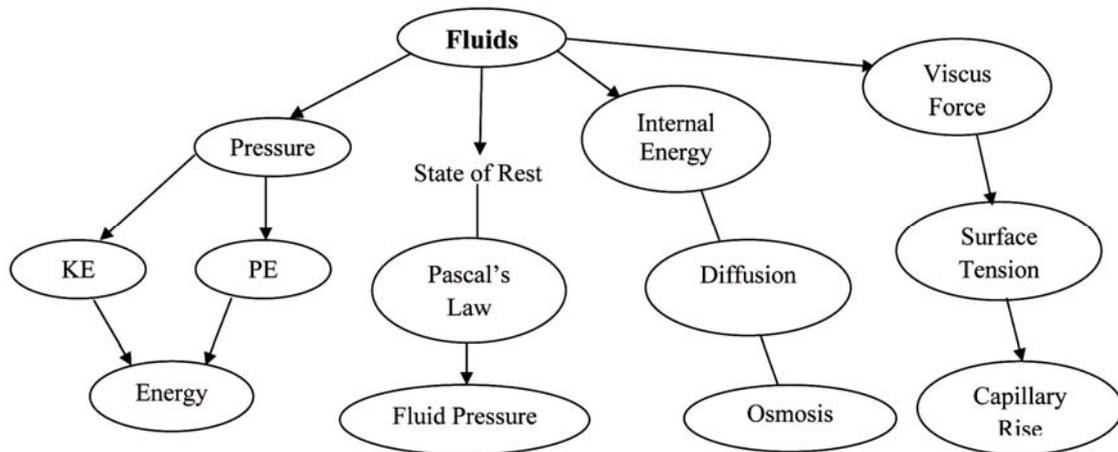

**LESSON PLAN – 3**

---

Standard	: VIII
Topic	: Liquid Pressure
Strategy	: <i>Conceptual Change</i>
Time	: 1 period

---

**Objectives** : To understand the concept of pressure. To make the pupils understand about that the liquids can exert pressure not only to the bottom of the container but also to the walls of container. Also to understand that water in dams exert more pressure to the bottom of the concrete walls.

**Concepts** : Pressure, Area, Dissipative Pressure

**Liquid Pressure**

Step 1 : Teacher categorizes preconceptions and misconceptions about pressure.

Step 2 : Asking students to predict what will happen to the given situation.

Step 3 : Explains with the help of evidences why preconceptions and misconceptions are error regarding pressure to students.

Step 4 : Teacher explains concept of pressure well.

Teacher introduces the following situations to students and ask to predict what will be the result and its reasons.

Put holes on plastic container of same shape at various heights. Fill up the containers with water and allow to flow through each hole and mark the distance reached by the gushed water.

Teacher contrast childrens ideas with the right explanations and give the idea that,

The height of hole pricked on the container determines the flow strength. As height increases the strength of current decreases.

Allow all the holes to open simultaneously. Water from the lower most hole covers maximum distance and the next top covers less than distance than the bottom one. So it can be concluded that the pressure exerted by liquid column is increasing as goes down.

‘Rapture in dam will cause catastrophic effects’ can be understood by examining height of dam, height of water level, area of reservoir which is clarified by the teacher to students.

### LESSON PLAN - 4

**Standard** : VIII  
**Topic** : Relative Density  
**Strategy** : *Concept Map*  
**Time** : 1 period

**Objectives** : To understand the concept of density and relative density.

**Concepts** : Density, Relative density

Attach an iron pin to the eraser of a portion of pencil and dip into water so that the pencil is perpendicular to the water surface. Mark the position of lower part of pencil. Repeat the experiment with kerosene (Fig). It is seen that pencil sinked more in water than kerosene.

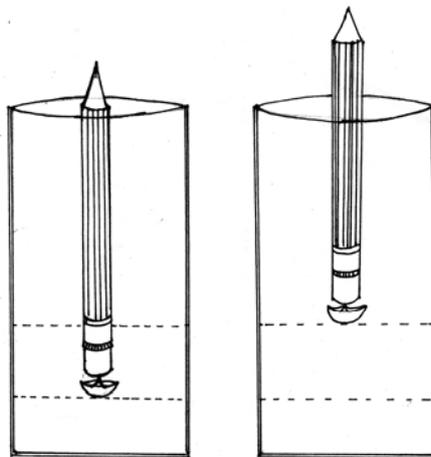

Put egg in water taken in a container. Egg will set down at the bottom. Repeat the experiment in salt water. It is observed that egg floats in salt water. Difference in density causes the egg to float and sink.

Reason for pencil to stay up is due to the high density of kerosene compared to water.

With the help of above demonstrated examples teacher explains the concept of relative density with respect to water.

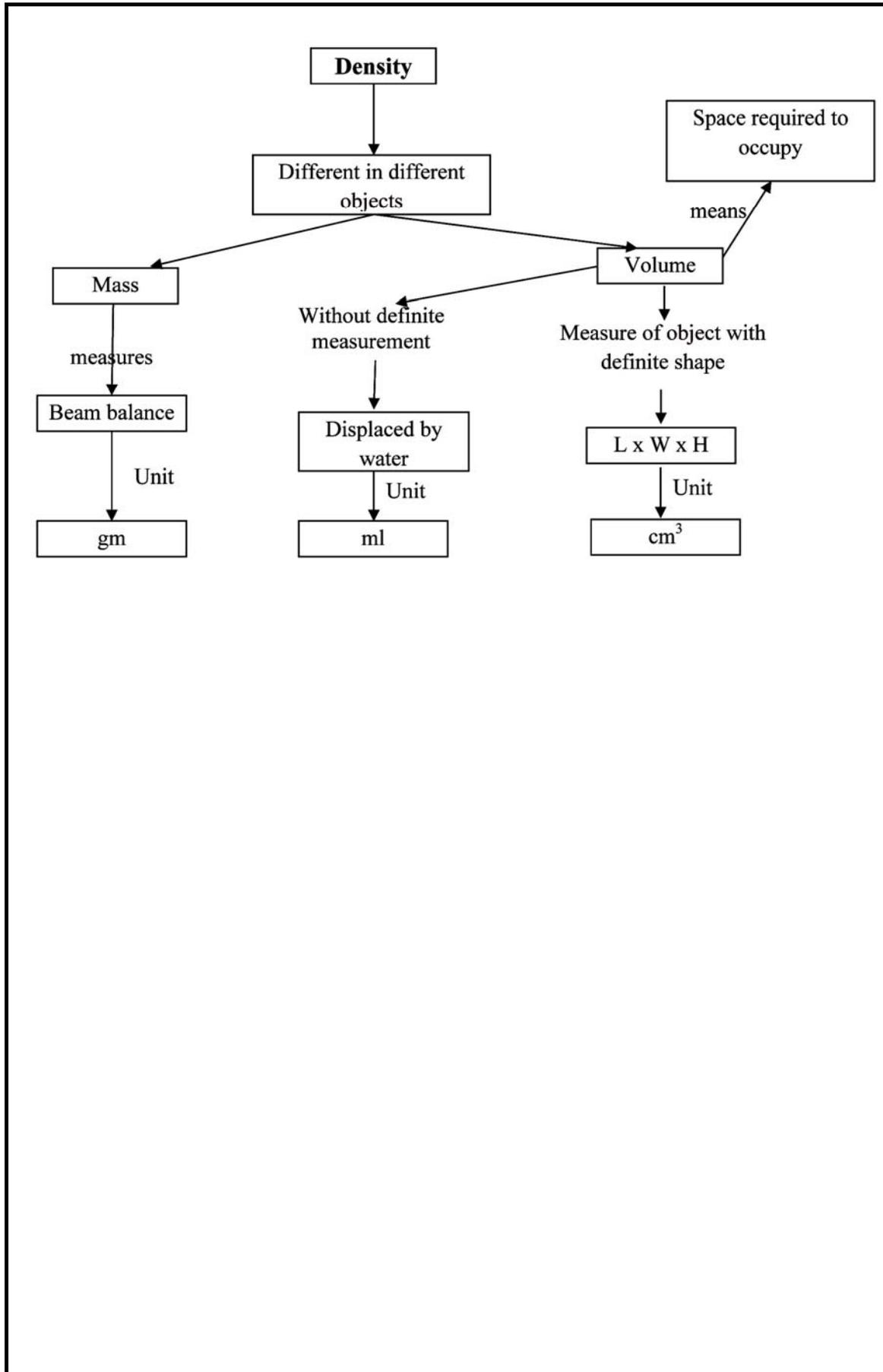

## LESSON PLAN - 5

---

<b>Standard</b>	<b>: VIII</b>
<b>Topic</b>	<b>: Magnetism-Magnetic Field</b>
<b>Strategy</b>	<b>: <i>Conceptual Change</i></b>
<b>Time</b>	<b>: 2 periods</b>

---

**Objectives** : To understand magnetism, magnetic objects, etc.  
 To detect the presence of magnetic lines of force

**Concepts** : Magnetism, magnet, magnetic field, magnetic poles, magnetic lines of force, etc.

Step 1 : Teacher tables the pre conceptions and misconceptions regarding magnetic field.

Step 2 : Asking students to predict what will happen in the given situation.

Step 3 : Teacher explains why the preconceptions are misconceptions are incorrect with the help of activities.

Step 4 : Teacher gives correct explanations to the concepts

Teacher introduces the following situations to students and ask to predict what will be the result and its reasons.

Sprinkle iron powder over a transparent glass sheet. Allow a magnet to move under the sheet. Which forms a particular pattern with iron powder and found the lines starts from one end of the magnet and ends in the other end.

Teacher contrast childrens ideas with the right explanations and give the idea of magnetic field.

Teacher introduces the following situations to students and ask to predict what will be the result and its reasons.

Repeat the experiment with two bar magnets keep at a fixed distance.

Teacher contrast childrens ideas with the right explanations and give the idea,

It can be seen that lines starts from the north pole of a magnet and ends in the south pole of other one.

Asking students to observe what will happen if the poles are exchanged.

Replace iron powder with compass needle and ask children to draw lines of force (as in fig.). It proves that magnetic lines of force starts from one end and terminates in other end.

Magnet can attract an iron needle kept at a particular distance closer to the magnetic. With the help of examples teacher explains magnetism and magnetic field and the properties of magnetic lines of force.

## LESSON PLAN - 6

---

Standard	: VIII
Topic	: Electro Magnetic Field
Strategy	: <i>Conceptual Change</i>
Time	: 1 period

---

**Objectives** : To understand the process of electro magnetization. To familiarize students with electro magnet, permanent magnet, magnetic induction, etc.

**Concepts** : Magnetism, magnetic induction, magnetic field, etc.

---

Step 1 : Teacher classifies preconceptions and misconceptions regarding electro-magnetic field.

Step 2 : Asking students to predict what will happen in the given situation.

Step 3 : With the help of given activities, teacher explains the incorrectness in the preconceptions and misconceptions about electro-magnetism.

Step 4 : Teacher gives correct explanations.

### **Electricity Produces Magnetic Field**

Demonstrates the attractive nature of magnets and formation of magnetic lines of force.

Teacher introduces the following situations to students and ask to predict what will be the result and its reasons.

Wound a copper-wire on iron nail connect both ends of copper wire to a battery. Pour iron filings around the copper wire.

Teacher contrast childrens ideas with the right explanations and give the idea that,

→ When battery is connected in circuit, it can be seen that the iron filings are get attracted to the wire. Hence it is proved that during the passage of electricity the copper wire is acting as a temporary magnet or showing magnetic properties.

Teacher introduces the following situations to students and ask to predict what will be the result and its reasons.

Keep a copper wire passing through the horse shoe magnet as shown in figure (1). Connect ends of wire to battery terminal and pass current through it.

Teacher contrast childrens ideas with the right explanations and give the idea of sudden dislocation of wire in a direction can be seen whenever it comes in connection with battery. Reversing the connection of battery terminal will move the wire in opposite direction. Reason behind the jerking is the reaction between natural magnetic field and formed temporary magnetic field. With the help of activities students learn the formation of electromagnet.

**LESSON PLAN - 7**

---

**Standard** : VIII  
**Topic** : Static Electricity  
**Strategy** : *Concept Map*  
**Time** : 2 periods

---

**Objectives** : To understand the fact that rubbing can charge materials and can attain the attractive or repulsive forces. To help children to develop concept map on static electricity.

**Concepts** : Static electricity, electroscope, lightning, arrestor, earthing, etc.

---

Rub the two hanging balls with leather or wool. Allow them to come in contact. It is seen that both balls are repelling.

Secondly rub one ball with leather and the other with rubber. Both of the balls get attracted each other.

Touch one ball with hard rubber rubbed by leather and the other ball with a glass rod rubbed by silk. It can be seen that both balls are get attracted. From this it is concluded that by rubbing suitable pairs electrons are transferred each other. The material which got electrons get charged as negative and the one which lost electrons get charged as positive. The transferred charge will stay at the same position in the material. Such electricity is called static electricity.

During rubbing between glass rod and silk, electrons are transferred to silk. It got negative charge and glass rod got positive charge.

When rubbing glass rod with leather electrons get displaced to glass rod hence glass rod get charged negative.

Rubbing between suitable objects cause static electricity.

In another activity show a spoon rubbed with woolen cloth in a foundation. It can be seen that the water lines are get attracted to the spoon. Finally when came contact with water electricity conducts through water and charge from spoon get earthed.

Rub air filled balloons in a woolen cloth let it to be in contact. Both of it are repel back since the negative charge formed on the surface of the balloons but the balloons will stick on to cloth since they are charged by opposite charges.

With the help of teacher students prepares concept map on static electricity. Grasps the application of lightening arrester and earthing.

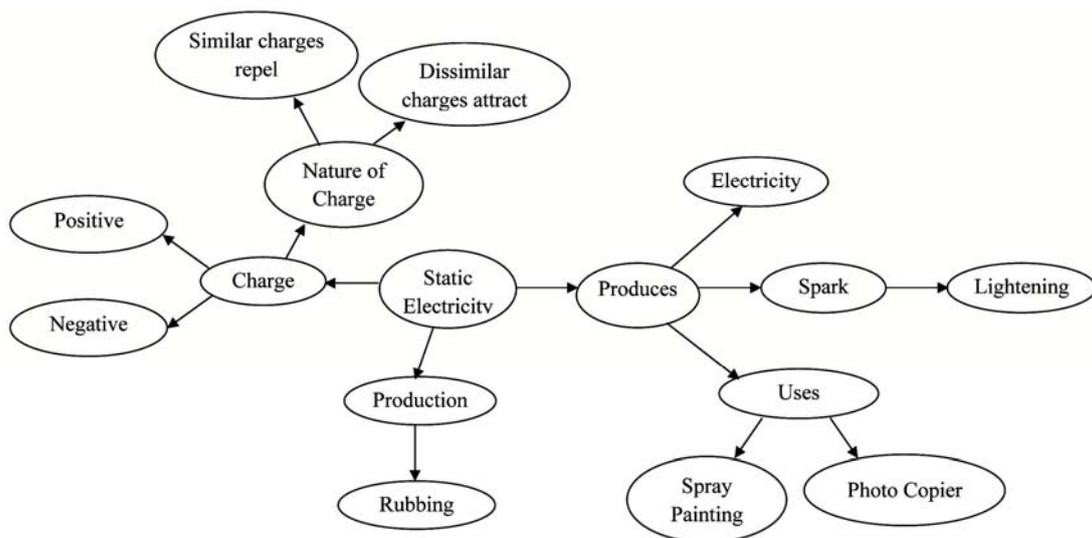

## LESSON PLAN - 8

---

Standard	: VIII
Topic	: Inertia
Strategy	: <i>Conceptual Change</i>
Time	: 2 periods

---

**Objectives** : To develop the concept of inertia. To identify inertia of motion and inertia of rest. To understand the life situations where inertia plays a key role and its relation with mass.

**Concepts** : Inertia, Mass

---

Step 1 : Teacher categorizes the preconceptions and misconceptions regarding inertia.

Step 2 : Asking students to predict what will happen in given situation

Step 3 : Preconceptions and misconceptions get clarified with the help of examples and activities.

Step 4 : Teacher explains the concept well.

### **Inertia I**

Teacher asks to observe the changes happening to the doll placed in a toy car. After keying the toy car it starts to move forward then the doll fall down backward. Likewise when toy car stops abruptly the doll falls to the front. Asking students to predict the reason behind each action.

Teacher introduces the situation to students and ask to predict what will be the result and its reasons.

Teacher contrast childrens ideas with the right explanations and give the idea that, a body always show the tendency to continue to the state of rest or uniform motion. Which is termed as inertia. Explains the concept with more examples.

1. Passengers getting down from a running bus compelled to run along the direction of bus after jumping.
2. Fan continues to rotate even after switching off electricity.
3. Kicking away the bottom placed coin from a pillar of coins without disturbing the pillar.
4. Make an arrangement of coin placed over a cardboard piece kept on an empty glass. Suddenly pull the card so that the coin will fall into empty glass.
5. Place a waterfilled cup and saucer on a kerchief. Sudden pulling of cloth wont make any changes in cap and successor arrangement.

### **Inertia II**

Teacher introduces the following situations to students and ask to predict what will be the result and its reasons.

When water in a saucer, suddenly shaken to one side. The water in the saucer was at rest till shaking. It will show a tendency to continue in its state hence the water will move and drip against the direction of shaking.

Teacher contrast childrens ideas with the right explanations and give the idea,

Teacher introduces the following situations to students and ask to predict what will be the result and its reasons.

Take two eggs, one fresh and other boiled. Rotate them simultaneously on a table. Stop the rotate on with a touch. After withdrawing fingers the fresh egg will continue its rotation. Teacher contrast childrens ideas with the right explanations and give the idea that, since the fleet content in fresh egg will have the tendency to continue in the static of motion due it inertia.

Move a jug containing  $\frac{3}{4}$ <sup>th</sup> water along table and withdraw hands suddenly. The water in jug will tend to move and hence to jug will move a little bit.

From the above examples pupils differentiates inertia of rest and inertia of motion and classifies suitable examples from daily life.

## LESSON PLAN - 9

**Standard** : VIII

**Topic** : Displacement and Distance Travelled

**Strategy** : *Concept Map*

**Time** : 1 period

**Objectives** : To develop the concept of scalar and vector  
Differentiate displacement and distance travelled.

**Concepts** : Scalar quantities, vector quantities distance, displacement, etc.

The shortest distance (straight line measurement) between the starting point and ending point of a moving object is termed as displacement.

Teacher throws a chalk piece to ground through window of the classroom and asked a student to get it. The distance covered by the student to get the chalk and the shortest distance between chalk and class is measured. From this teacher explains distance and displacement.

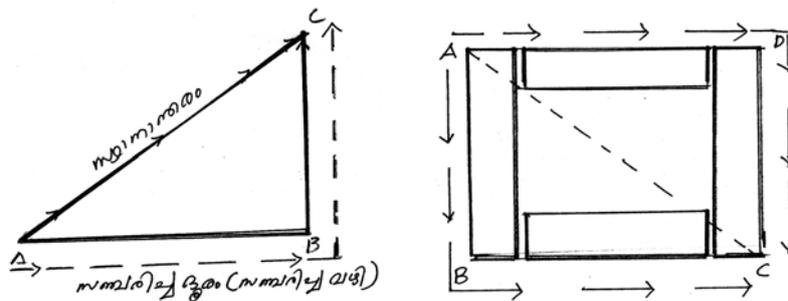

Teacher asked students to arrange benches in classroom as in figure. Then asked a student to place a book at 'C' from 'A' through 'C'. Then calculated the distance travelled by book and displacement happened to book.

With the help of life related example teacher explains distance travelled and displacement.

From the examples students understand the difference between distance travelled and displacement and hence prepares concept map based on the ideas obtained. Teacher consolidates the class and corrects the concept map prepared by students.

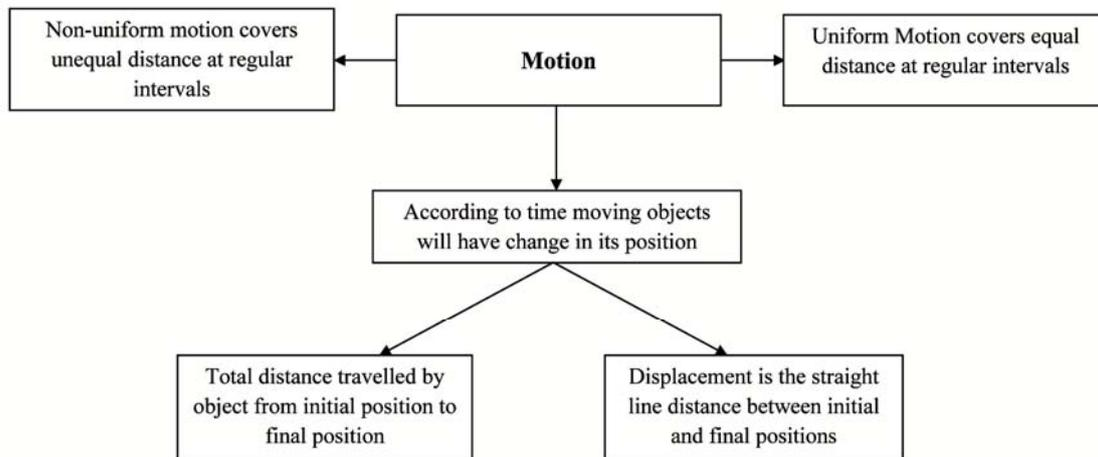

## LESSON PLAN - 10

---

**Standard** : VIII  
**Topic** : Centrifugal Force, Centripetal Force  
**Strategy** : *Conceptual Change*  
**Time** : 1 period

---

**Objectives** : To develop the concept of force, and two different types centrifugal and centripetal.

**Concepts** : Force, internal force, external force, direction of force, acceleration, etc.

---

Step 1 : The preconceptions and misconceptions regarding centripetal/centrifugal force is categorized.

Step 2 : Asking students to predict what will happen to the given situation

Step 3 : Teacher explains the errors in preconceptions and misconceptions and gives detailed disruption of concept.

Step 4 : Teacher explains the concept well.

Teacher introduces the following situations to students and ask to predict what will be the result and its reasons.

Half fill the bucket with water and circulate it in air, the water in the bucket will not come out, and will stay in bucket itself.

Teacher contrast childrens ideas with the right explanations and give the idea that,

The reason behind the phenomenon is the centrifugal force exerted by water to the bottom of bucket. The speed of rotation provides required

centrifugal force to water to exert on the walls of container when the speed slowdown water will start to flow since the force diminishes.

Teacher introduces the following situations to students and ask to predict what will be the result and its reasons.

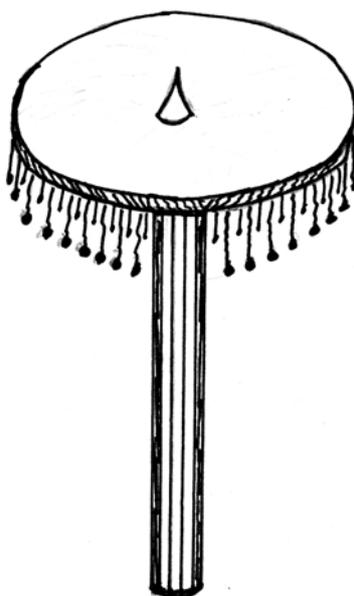

Demonstrate the toy in figure. The connected beads will follow a particular path while rotating the toy along the axis. Teacher contrast childrens ideas with the right explanations and give the idea that, the movement of the beads is due to the centrifugal force which is explained by teacher. Centrifugal force is that one which acts outwards along radius when an object revolves around a fixed centre.

Similarly force acting radially inwards is termed as centripetal force. The application of centripetal force comes in 'banking of curves'. During the twist and turn along road the vehicle will not undergo skidding or accident

which is due to the centripetal force acting radially inward which protects vehicle from skidding out in the curved road.

Teacher gives example of merry go-round to explain centripetal force.

Teacher asks to list out centripetal and centrifugal forces with the situations where they play in daily life.

**LESSON PLAN - 11**

---

**Standard** : VIII  
**Topic** : Why Sky Appears Blue?  
**Strategy** : *Conceptual Change*  
**Time** : 1 period

---

**Objectives** : To understand the phenomenon of scattering. To observe what will happen to the composite colours of white light while undergoing dispersion.

---

Step 1 : Teacher categorizes the preconceptions and misconceptions about the blueness of the sky

Step 2 : Teacher asks to predict what will happen to the given situation

Step 3 : With the help of examples given teacher rectifies the preconceptions and misconceptions.

Step 4 : Teacher gives correct explanation

Teacher explains scattering of light. How does the particle in atmosphere causes scattering- Human eye is perceiving the net blue colour (Violet, Indigo, Blue) of the spectrum, and hence the sky appears the total blue.

Teacher introduces the following situations to students and ask to predict what will be the result and its reasons.

Take a jar full of water. Add few drops of milk in it. Continue till the solution become opaque due to presence of milk in water.

Keep a flash light on one side of the jar. Light get scattered by water molecules and the whole solution appears in another colour.

Teacher contrast childrens ideas with the right explanations and give the idea that, the reason behind the blueness of ocean, redness of sky during sun rise and sunset is discussed in classroom.

**LESSON PLAN - 12**

---

**Standard** : VIII**Topic** : Sound**Strategy** : *Participative Approach***Time** : 4 periods

---

**Objectives** : To identify basic features of sound. To understand that vibration or oscillations are the cause of sound.

**Concepts** : Vibration, Oscillation, Sound wave, Frequency, Audible range.

---

To understand that sound is formed due to vibration teacher provides various situations where sound is produced.

1. While talking asked students to feel the vibration of their vocal cord by feather touching the pharynx (front of neck).
2. Showing the vibration of speaker while operating radio.
3. Asked children to move the teeth of hair comb along a sharp edge. A particular sound is produced due to the vibration of its teeth.
4. Fixing one end of metallic scale on a bench/desk and inching on other free end will make a particular sound. Which induce to the vibration of free end.
5. Hit a freely hanging iron pipe with another iron pipe. The hanging pipe will produce a particular sound. Allow the excited pipe to come in contact with still water taken in a plate. The spreading vibration in the form of waves can be seen.

6. Demonstrate the sound production in tuning fork, by exciting it with a hammer.

### Propagation of Sound

For the propagation, a medium is essential to sound which is made clear using the following examples.

→ Tie a spoon in the middle portion of a fine thread and stretch the thread as much as possible. Then hit the spoon with another metallic object. One can hear a particular sound if the ends of thread is kept close to the ear. Which shows the transmission of sound.

→ Repeat the experiment with two pencils tied at both ends of thread. One can hear sound at any end again showing sound is getting transmitted.

→ Connect two disposable paper glasses with a thread. Ask students to use it as a telephone to converse each other.

Both of them can hear one another clearly. Repeat the experiment by tying a piece of wood middle to the thread. Again the conversation is audible to children. Here the sound is transmitting through three media, paper cup, thread and wood.

Students grasp the phenomenon behind sound production and the means of sound propagation.

## LESSON PLAN - 13

---

**Standard** : VIII  
**Topic** : Composite Colours of Light  
**Strategy** : *Conceptual Change*  
**Time** : 1 period

---

**Objectives** : To understand that the visible light is made up of different colours

**Concepts** : Dispersion, composite, colours, primary colours, secondary colours.

---

Step 1 : Teacher categorizes the pre conceptions

Step 2 : Asking students to predict what will happen to the situation given by teacher.

Step 3 : Preconceptions and misconceptions are getting cleared with the help of different activities

Step 4 : Teacher explains 'Concepts'

Teacher introduces the following situations to students and ask to predict what will be the result and its reasons.

From a soap bubble in a glass tumbler. Keep the arrangement between a lit candle and a white paper it can be seen that various colours are reflecting on white paper. From the light coming from candle through the bubble. Which shows that the visible light is composed of different colours. Teacher contrast childrens ideas with the right explanations and give the idea of colour.

Teacher introduces the following situations to students and ask to predict what will be the result and its reasons.

Cover two torches with differently coloured transparent papers. Focus both lights on same point one can observe a 3<sup>rd</sup> colour there.

Teacher introduces the following situations to students and ask to predict what will be the result and its reasons.

Repeat the experiment with a third torch each bearing primary colour, i.e., green, blue and red. Teacher contrast childrens ideas with the right explanations and give the idea that, the common focus will appear in white.

With the help of these activities students learn composite of light.

**LESSON PLAN -14**

---

**Standard** : VIII  
**Topic** : Refraction  
**Strategy** : *Conceptual Change*  
**Time** : 1 period

---

**Objectives** : To understand the concept of refraction

**Concepts** : Refraction, path of the light, media, reflection, density difference of media.

---

Step 1 : Teacher categorizes the common preconceptions and misconceptions about laws of motion.

Step 2 : Asking students to predict what will happen to the situation given by teacher.

Step 3 : Preconceptions and misconceptions are getting cleared with the help of different activities

Step 4 : Teacher explains 'Concepts'

Teacher introduces the following situations to students and ask to predict what will be the result and its reasons.

Keep a coin in a glass tumbler, ask a student to watch this and move back so that the coin disappears from visibility and glass is still visible. Pour few water in tumbler then coin will appear to the student. Teacher contrast childrens ideas with the right explanations and give the reason behind the phenomenon.

→ Keep a ruler, or pencil in glass jar with water. It can be seen that the object has a bend on the surface of separation of air and water. Teacher explains the reason by combining both activities.

Teacher introduces the following situations to students and asks to predict what will be the result and its reasons.

Draw a straight line in a white paper. Keep a water-filled transparent bottle over the line. It is seen that the line has broken at the place where the bottle is kept. Teacher contrasts children's ideas with the right explanations and gives the idea that vision is possible when a light ray reaches eyes after reflecting on objects. As the ray traverses through various media it will suffer a slight change (deviation) in path. Hence the ray reaching eyes will produce the image in the direction of it so that a distorted image is obtained. That is why pencil ruler, straight line etc. are found as broken.

Teacher concludes the portion with life-related examples.